



METHODOLOGY

Version ~~1.56~~

# Powerlink Pricing Methodology

## ~~REVISED~~ PROPOSED AMENDED PRICING METHODOLOGY 1 JULY 2022 TO 30 JUNE 2027

Document identifier:	<del>Revised</del> Proposed <u>Amended</u> Pricing Methodology	Authored by:	<del>Ben-Wu</del> Network Regulation
Document version:	Version 1. <del>56</del>	Checked by:	Jennifer Harris
Date of current issue:	<del>October-2024</del> <u>November 2022</u>	Approved by:	Jacqui Bridge
Date of AER approval:	<del>April-2022</del> <u>January 2023</u>		

[Revised Proposed Pricing Methodology](#) ~~Revised Proposed~~ Amended Pricing Methodology

**ANY PRINTED COPY OF THIS DOCUMENT IS UNCONTROLLED**

© Powerlink Queensland

For information about Powerlink visit [www.powerlink.com.au](http://www.powerlink.com.au).

## Contact

For enquiries about this Pricing Methodology please contact:

Group Manager Network Regulation  
Powerlink  
PO Box 1193, Virginia  
Queensland 4014

[jenny.harris@powerlink.com.au](mailto:jenny.harris@powerlink.com.au)

This is Powerlink's **Revised**  
Proposed **Amended** Pricing  
Methodology for the regulatory  
period from 1 July 2022 to 30 June  
2027. This document will be lodged  
with the Australian Energy  
Regulator (AER) by **December**  
**November 2021-2022** for approval.



# Powerlink Pricing Methodology

## Table of Contents

<b>1</b>	<b>INTRODUCTION</b>	<b>1</b>
<b>2</b>	<b>INTERPRETATION</b>	<b>1</b>
<b>3</b>	<b>PRESCRIBED TRANSMISSION SERVICES</b>	<b>1</b>
<b>4</b>	<b>RULES REQUIREMENTS</b>	<b>2</b>
<b>5</b>	<b>PRICING METHODOLOGY GUIDELINES REQUIREMENTS</b>	<b>4</b>
<b>6</b>	<b>PRICING METHODOLOGY</b>	<b>6</b>
6.1	Background	6
6.2	Single Transmission Network Service Provider	6
6.3	Aggregate Annual Revenue Requirement (AARR)	7
6.4	Categories of transmission services	7
6.5	Cost allocation	8
6.6	Calculation of the attributable cost share for each category of service	9
6.7	Calculation of the Annual Service Revenue Requirement (ASRR)	10
6.8	Allocation of the ASRR to transmission network connection points	10
	<b>6.8.1 Prescribed entry services</b>	<b>11</b>
	<b>6.8.2 Prescribed exit services</b>	<b>12</b>
	<b>6.8.3 Prescribed Transmission Use of System (TUOS) services</b>	<b>12</b>
	<b>6.8.3.1 Prescribed TUOS services – locational component</b>	<b>13</b>
	<b>6.8.3.2 Prescribed TUOS services – non- locational component</b>	<b>14</b>
6.9	Transmission prices and charges	14
	<b>6.9.1 Prescribed entry and exit services prices and charges</b>	<b>14</b>
	<b>6.9.2 Prescribed TUOS services – locational component prices and charges</b>	<b>15</b>
	<b>6.9.3 Prescribed TUOS services – non-locational component prices and charges</b>	<b>16</b>
	<b>6.9.4 Prescribed common service prices and charges</b>	<b>17</b>
6.10	System Strength Charges	19
	<b>6.10.1 Overview of the charging arrangements</b>	<b>19</b>
	<b>6.10.2 System Strength Unit Price</b>	<b>20</b>
6.11	Standby service arrangements	22
6.12	Excess demand charge	22
6.13	Setting of TUOS locational prices between annual price publications	23
<b>7</b>	<b>BILLING ARRANGEMENTS</b>	<b>24</b>
7.1	Billing for prescribed transmission services	24
7.2	Intra-Regional Payments between Transmission Network Service Providers	24
<b>8</b>	<b>PRUDENTIAL REQUIREMENTS</b>	<b>25</b>
8.1	Prudential requirements for prescribed transmission services	25

Formatted: Tab stops: 14.63 cm, Right



# Powerlink Pricing Methodology

8.2 Capital contribution or prepayment for a specific asset .....25

**9 PRUDENT DISCOUNTS 25**

**10 MONITORING AND COMPLIANCE 26**

**11 NEW CONNECTIONS REQUIRING SIGNIFICANT INVESTMENT 26**

11.1 Impact on TUOS locational prices in cases of significant investment.....26

11.2 Setting TUOS locational prices in the first year of significant investment.....26

**12 TRANSITIONAL ARRANGEMENTS TO IMPLEMENT THE PRICING METHODOLOGY 27**

**13 ADDITIONAL INFORMATION REQUIREMENTS 27**

**14 DESCRIPTION OF PRICING METHODOLOGY DIFFERENCES 28**

**15 SUMMARY 28**

**APPENDIX A - STRUCTURE OF TRANSMISSION PRICING UNDER PART J OF RULES 29**

**APPENDIX B - DETAILS OF COST ALLOCATION PROCESS 31**

**APPENDIX C - COST REFLECTIVE NETWORK PRICING METHODOLOGY 33**

Steps 33

Allocation of Generation to Load .....33

Operating Conditions for Cost Allocation .....33

Load and generation data.....34

**APPENDIX D - MODIFIED LOAD EXPORT CHARGE COST REFLECTIVE NETWORK PRICING METHODOLOGY 35**

Introduction .....35

Overview of the process .....35

Timetable for the provision of data .....39

Billing the modified load export charge .....41

Worked example – modified load export charge.....41

Step 1 – Aggregate annual revenue requirement (AARR).....41

Step 2 – Annual service revenue requirement .....42

Step 3 – Adjustment for settlement residue auction proceeds.....43

Step 4 – Standard CRNP Calculation.....43

Step 5 – Modified load export charge to be recovered .....44

**APPENDIX E - PRIORITY ORDERING METHODOLOGY 45**

Rules Requirements .....45

Objective and General Approach .....46

Formatted: Tab stops: 14.63 cm, Right



# Powerlink Pricing Methodology

Methodology.....46

    Step 1: Branch Identification .....46

    Step 2: Allocation of Circuit Breakers to Branches .....46

    Step 3.1: Stand-alone arrangements for Prescribed TUOS .....47

    Step 3.2: Stand-alone arrangements for Prescribed common transmission services .....47

    Step 4: Allocation of substation infrastructure and establishment costs .....47

Definition - Branches.....48

Examples .....49

## APPENDIX F – SYSTEM STRENGTH CHARGES 58

1 INTRODUCTION 1

2 INTERPRETATION 1

3 PRESCRIBED TRANSMISSION SERVICES 1

4 RULES REQUIREMENTS 2

5 PRICING METHODOLOGY GUIDELINES REQUIREMENTS 3

6 PRICING METHODOLOGY 5

6.1 Background .....5

6.2 Single Transmission Network Service Provider .....5

6.3 Aggregate Annual Revenue Requirement (AARR) .....6

6.4 Categories of transmission services .....6

6.5 Cost allocation .....7

6.6 Calculation of the attributable cost share for each category of service .....8

6.7 Calculation of the Annual Service Revenue Requirement (ASRR) .....9

6.8 Allocation of the ASRR to transmission network connection points .....9

    6.8.1 Prescribed entry services .....9

    6.8.2 Prescribed exit services .....10

    6.8.3 Prescribed Transmission Use of System (TUOS) services .....11

        6.8.3.1 Prescribed TUOS services – locational component .....11

        6.8.3.2 Prescribed TUOS services – non-locational component .....12

6.9 Transmission prices and charges .....13

    6.9.1 Prescribed entry and exit services prices and charges .....13

    6.9.2 Prescribed TUOS services – locational component prices and charges .....13

    6.9.3 Prescribed TUOS services – non-locational component prices and charges .....14

    6.9.4 Prescribed common service prices and charges .....16

6.10 System Strength Charges .....18

    6.10.1 Overview of the charging arrangements .....18

    6.10.2 System Strength Unit Price .....18

6.11 Standby service arrangements .....20

Formatted: Tab stops: 14.63 cm, Right



# Powerlink Pricing Methodology

6.12 Excess demand charge .....21

6.13 Setting of TUOS locational prices between annual price publications .....21

**7 BILLING ARRANGEMENTS ..... 22**

7.1 Billing for prescribed transmission services .....22

7.2 Intra-Regional Payments between Transmission Network Service Providers .....22

**8 PRUDENTIAL REQUIREMENTS ..... 23**

8.1 Prudential requirements for prescribed transmission services .....23

8.2 Capital contribution or prepayment for a specific asset .....23

**9 PRUDENT DISCOUNTS ..... 23**

**10 MONITORING AND COMPLIANCE ..... 24**

**11 NEW CONNECTIONS REQUIRING SIGNIFICANT INVESTMENT ..... 24**

11.1 Impact on TUOS locational prices in cases of significant investment .....24

11.2 Setting TUOS locational prices in the first year of significant investment .....24

**12 TRANSITIONAL ARRANGEMENTS TO IMPLEMENT THE PRICING METHODOLOGY ..... 25**

**13 ADDITIONAL INFORMATION REQUIREMENTS ..... 25**

**14 DESCRIPTION OF PRICING METHODOLOGY DIFFERENCES ..... 26**

**15 SUMMARY ..... 26**

**APPENDIX A - STRUCTURE OF TRANSMISSION PRICING UNDER PART J OF RULES ..... 27**

**APPENDIX B - DETAILS OF COST ALLOCATION PROCESS ..... 28**

**APPENDIX C - COST REFLECTIVE NETWORK PRICING METHODOLOGY ..... 30**

Steps .....30

Allocation of Generation to Load .....30

Operating Conditions for Cost Allocation .....30

Load and generation data .....31

**APPENDIX D - MODIFIED LOAD EXPORT CHARGE COST REFLECTIVE NETWORK PRICING METHODOLOGY ..... 32**

Introduction .....32

Overview of the process .....32

Timetable for the provision of data .....35

Formatted: Tab stops: 14.63 cm, Right



# Powerlink Pricing Methodology

Billing the modified load export charge .....36  
Worked example – modified load export charge .....36  
    Step 1 – Aggregate annual revenue requirement (AARR).....36  
    Step 2 – Annual service revenue requirement .....37  
    Step 3 – Adjustment for settlement residue auction proceeds.....38  
    Step 4 – Standard CRNP Calculation.....38  
    Step 5 – Modified load export charge to be recovered .....39

**APPENDIX E – PRIORITY ORDERING METHODOLOGY ..... 40**  
Rules Requirements .....40  
Objective and General Approach .....41  
Methodology.....41  
    **Step 1: Branch Identification** .....41  
    **Step 2: Allocation of Circuit Breakers to Branches** .....41  
    **Step 3.1: Stand-alone arrangements for Prescribed TUOS** .....42  
    **Step 3.2: Stand-alone arrangements for Prescribed common transmission services** .....42  
    **Step 4: Allocation of substation infrastructure and establishment costs** .....42  
Definition – Branches.....43  
Examples .....44

**APPENDIX F – SYSTEM STRENGTH CHARGES ..... 52**

1 – Introduction ..... 1  
2 – Interpretation ..... 1  
3 – Prescribed Transmission Services ..... 1  
4 – Rules Requirements ..... 2  
5 – Pricing Methodology Guidelines Requirements ..... 3  
6 – Pricing Methodology ..... 5  
6.1 – Background .....5  
6.2 – Single Transmission Network Service Provider .....5  
6.3 – Aggregate Annual Revenue Requirement (AARR) .....6  
6.4 – Categories of transmission services.....6  
6.5 – Cost allocation.....7  
6.6 – Calculation of the attributable cost share for each category of service .....8  
6.7 – Calculation of the Annual Service Revenue Requirement (ASRR) .....9  
6.8 – Allocation of the ASRR to transmission network connection points .....9  
    **6.8.1 – Prescribed entry services** .....9  
    **6.8.2 – Prescribed exit services** .....10  
    **6.8.3 – Prescribed Transmission Use of System (TUOS) services** .....11  
    **6.8.3.1 – Prescribed TUOS services – locational component** .....11

Formatted: Tab stops: 14.63 cm, Right



# Powerlink Pricing Methodology

<del>6.8.3.2</del>	<del>Prescribed TUOS services – non-locational component</del>	<del>12</del>
<del>6.9</del>	<del>Transmission prices and charges</del>	<del>13</del>
<del>6.9.1</del>	<del>Prescribed entry and exit services prices and charges</del>	<del>13</del>
<del>6.9.2</del>	<del>Prescribed TUOS services – locational component prices and charges</del>	<del>13</del>
<del>6.9.3</del>	<del>Prescribed TUOS services – non-locational component prices and charges</del>	<del>14</del>
<del>6.9.4</del>	<del>Prescribed common service prices and charges</del>	<del>16</del>
<del>6.10</del>	<del>System Strength Charges</del>	<del>18</del>
<del>6.10.1</del>	<del>Overview of the charging arrangements</del>	<del>18</del>
<del>6.10.2</del>	<del>System Strength Unit Price</del>	<del>18</del>
<del>6.11</del>	<del>Standby service arrangements</del>	<del>20</del>
<del>6.12</del>	<del>Excess demand charge</del>	<del>21</del>
<del>6.13</del>	<del>Setting of TUOS locational prices between annual price publications</del>	<del>21</del>
<del>7</del>	<del>Billing Arrangements</del>	<del>22</del>
<del>7.1</del>	<del>Billing for prescribed transmission services</del>	<del>22</del>
<del>7.2</del>	<del>Intra-Regional Payments between Transmission Network Service Providers</del>	<del>22</del>
<del>8</del>	<del>Prudential Requirements</del>	<del>23</del>
<del>8.1</del>	<del>Prudential requirements for prescribed transmission services</del>	<del>23</del>
<del>8.2</del>	<del>Capital contribution or prepayment for a specific asset</del>	<del>23</del>
<del>9</del>	<del>PRUDENT DISCOUNTS</del>	<del>23</del>
<del>10</del>	<del>Monitoring and Compliance</del>	<del>24</del>
<del>11</del>	<del>new CONNECTIONS REQUIRING SIGNIFICANT INVESTMENT</del>	<del>24</del>
<del>11.1</del>	<del>Impact on TUOS locational prices in cases of significant investment</del>	<del>24</del>
<del>11.2</del>	<del>Setting TUOS locational prices in the first year of significant investment</del>	<del>24</del>
<del>12</del>	<del>Transitional Arrangements to implement the Pricing methodology</del>	<del>25</del>
<del>13</del>	<del>Additional information requirements</del>	<del>25</del>
<del>14</del>	<del>Description of pricing methodology differences</del>	<del>26</del>
<del>15</del>	<del>Summary</del>	<del>26</del>
<del>Appendix A</del>	<del>Structure of Transmission Pricing under Part J of Rules</del>	<del>27</del>
<del>Appendix B</del>	<del>Details of Cost Allocation Process</del>	<del>28</del>
<del>Appendix C</del>	<del>Cost Reflective Network Pricing Methodology Steps</del>	<del>30</del>





# Powerlink Pricing Methodology

Allocation of Generation to Load .....30  
Operating Conditions for Cost Allocation .....30  
Load and generation data .....31

Appendix D – Modified Load Export Charge Cost Reflective Network Pricing Methodology .....32  
Introduction .....32  
Overview of the process .....32  
Timetable for the provision of data .....35  
Billing the modified load export charge .....36  
Worked example – modified load export charge .....36  
    Step 1 – Aggregate annual revenue requirement (AARR) .....36  
    Step 2 – Annual service revenue requirement .....37  
    Step 3 – Adjustment for settlement residue auction proceeds .....38  
    Step 4 – Standard CRNP Calculation .....38  
    Step 5 – Modified load export charge to be recovered .....39

Appendix E – Priority Ordering Methodology .....40  
Rules Requirements .....40  
Objective and General Approach .....41  
Methodology .....41  
    Step 1: Branch Identification .....41  
    Step 2: Allocation of Circuit Breakers to Branches .....41  
    Step 3.1: Stand-alone arrangements for Prescribed TUOS .....42  
    Step 3.2: Stand-alone arrangements for Prescribed common transmission services .....42  
    Step 4: Allocation of substation infrastructure and establishment costs .....42  
Definition – Branches .....43  
Examples .....44

Appendix F – System Strength Charges .....52

1 – Introduction .....4  
2 – Interpretation .....1  
3 – Prescribed Transmission Services .....4  
4 – Rules Requirements .....2  
5 – Pricing Methodology Guidelines Requirements .....3  
6 – Pricing Methodology .....5  
    6.1 – Background .....5  
    6.2 – Single Transmission Network Service Provider .....5  
    6.3 – Aggregate Annual Revenue Requirement (AARR) .....6

Formatted: Tab stops: 14.63 cm, Right



# Powerlink Pricing Methodology

- 6.4 Categories of transmission services ..... 6
- 6.5 Cost allocation ..... 7
- 6.6 Calculation of the attributable cost share for each category of service ..... 8
- 6.7 Calculation of the Annual Service Revenue Requirement (ASRR) ..... 9
- 6.8 Allocation of the ASRR to transmission network connection points ..... 9
  - 6.8.1 Prescribed entry services ..... 10
  - 6.8.2 Prescribed exit services ..... 11
  - 6.8.3 Prescribed Transmission Use of System (TUOS) services ..... 11
    - 6.8.3.1 Prescribed TUOS services – locational component ..... 12
    - 6.8.3.2 Prescribed TUOS services – non-locational component ..... 13
- 6.9 Transmission prices and charges ..... 13
  - 6.9.1 Prescribed entry and exit services prices and charges ..... 13
  - 6.9.2 Prescribed TUOS services – locational component prices and charges ..... 13
  - 6.9.3 Prescribed TUOS services – non-locational component prices and charges ..... 15
  - 6.9.4 Prescribed common service prices and charges ..... 16
- 6.10 System Strength Charges ..... 18
  - 6.10.1 Overview of the charging arrangements ..... 18
  - 6.10.2 System Strength Unit Price ..... 19
- 6.11 Standby service arrangements ..... 21
- 6.12 Excess demand charge ..... 21
- 6.13 Setting of TUOS locational prices between annual price publications ..... 22
  
- 7 Billing Arrangements ..... 23
  - 7.1 Billing for prescribed transmission services ..... 23
  - 7.2 Intra-Regional Payments between Transmission Network Service Providers ..... 23
  
- 8 Prudential Requirements ..... 24
  - 8.1 Prudential requirements for prescribed transmission services ..... 24
  - 8.2 Capital contribution or prepayment for a specific asset ..... 24
  
- 9 PRUDENT DISCOUNTS ..... 24
  
- 10 Monitoring and Compliance ..... 25
  
- 11 new CONNECTIONS REQUIRING SIGNIFICANT INVESTMENT ..... 25
  - 11.1 Impact on TUOS locational prices in cases of significant investment ..... 25
  - 11.2 Setting TUOS locational prices in the first year of significant investment ..... 25
  
- 12 Transitional Arrangements to implement the Pricing methodology ..... 26
  
- 13 Additional information requirements ..... 26
  
- 14 Description of pricing methodology differences ..... 27

Formatted: Tab stops: 14.63 cm, Right



# Powerlink Pricing Methodology

15	Summary	27
	Appendix A – Structure of Transmission Pricing under Part J of Rules	28
	Appendix B – Details of Cost Allocation Process	30
	Appendix C – Cost Reflective Network Pricing Methodology	32
	Steps	32
	Allocation of Generation to Load	32
	Operating Conditions for Cost Allocation	32
	Load and generation data	33
	Appendix D – Modified Load Export Charge Cost Reflective Network Pricing Methodology	34
	Introduction	34
	Overview of the process	34
	Timetable for the provision of data	37
	Billing the modified load export charge	38
	Worked example – modified load export charge	38
	Step 1 – Aggregate annual revenue requirement (AARR)	38
	Step 2 – Annual service revenue requirement	39
	Step 3 – Adjustment for settlement residue auction proceeds	40
	Step 4 – Standard CRNP Calculation	40
	Step 5 – Modified load export charge to be recovered	41
	Appendix E – Priority Ordering Methodology	42
	Rules Requirements	42
	Objective and General Approach	43
	Methodology	43
	Step 1: Branch Identification	43
	Step 2: Allocation of Circuit Breakers to Branches	43
	Step 3.1: Stand-alone arrangements for Prescribed TUOS	44
	Step 3.2: Stand-alone arrangements for Prescribed common transmission services	44
	Step 4: Allocation of substation infrastructure and establishment costs	44
	Definition – Branches	45
	Examples	46
	Appendix F – System Strength Charges	54
1	INTRODUCTION	1
2	INTERPRETATION	1
3	PRESCRIBED TRANSMISSION SERVICES	1

Formatted: Tab stops: 14.63 cm, Right



# Powerlink Pricing Methodology

<b>4</b>	<b><u>RULES REQUIREMENTS</u></b>	<b>2</b>
<b>5</b>	<b><u>PRICING METHODOLOGY GUIDELINES REQUIREMENTS</u></b>	<b>3</b>
<b>6</b>	<b><u>PRICING METHODOLOGY</u></b>	<b>5</b>
6.1	Background	5
6.2	Single Transmission Network Service Provider	5
6.3	Aggregate Annual Revenue Requirement (AARR)	6
6.4	Categories of transmission services	6
6.5	Cost allocation	7
6.6	Calculation of the attributable cost share for each category of service	8
6.7	Calculation of the Annual Service Revenue Requirement (ASRR)	9
6.8	Allocation of the ASRR to transmission network connection points	9
	<b>6.8.1 Prescribed entry services</b>	10
	<b>6.8.2 Prescribed exit services</b>	11
	<b>6.8.3 Prescribed Transmission Use of System (TUOS) services</b>	11
	<b>6.8.3.1 Prescribed TUOS services – locational component</b>	12
	<b>6.8.3.2 Prescribed TUOS services – non-locational component</b>	13
6.9	Transmission prices and charges	13
	<b>6.9.1 Prescribed entry and exit services prices and charges</b>	13
	<b>6.9.2 Prescribed TUOS services – locational component prices and charges</b>	13
	<b>6.9.3 Prescribed TUOS services – non-locational component prices and charges</b>	15
	<b>6.9.4 Prescribed common service prices and charges</b>	16
6.10	System Strength Charges	18
	<b>6.10.1 Overview of the charging arrangements</b>	18
	<b>6.10.2 System Strength Unit Price</b>	19
6.11	Standby service arrangements	21
6.12	Excess demand charge	21
6.13	Setting of TUOS locational prices between annual price publications	22
<b>7</b>	<b><u>BILLING ARRANGEMENTS</u></b>	<b>23</b>
7.1	Billing for prescribed transmission services	23
7.2	Intra-Regional Payments between Transmission Network Service Providers	23
<b>8</b>	<b><u>PRUDENTIAL REQUIREMENTS</u></b>	<b>24</b>
8.1	Prudential requirements for prescribed transmission services	24
8.2	Capital contribution or prepayment for a specific asset	24
<b>9</b>	<b><u>PRUDENT DISCOUNTS</u></b>	<b>24</b>
<b>10</b>	<b><u>MONITORING AND COMPLIANCE</u></b>	<b>25</b>
<b>11</b>	<b><u>NEW CONNECTIONS REQUIRING SIGNIFICANT INVESTMENT</u></b>	<b>25</b>
11.1	Impact on TUOS locational prices in cases of significant investment	25
11.2	Setting TUOS locational prices in the first year of significant investment	25



# Powerlink Pricing Methodology

<b>12</b>	<b><u>TRANSITIONAL ARRANGEMENTS TO IMPLEMENT THE PRICING METHODOLOGY</u></b>	<b>26</b>
<b>13</b>	<b><u>ADDITIONAL INFORMATION REQUIREMENTS</u></b>	<b>26</b>
<b>14</b>	<b><u>DESCRIPTION OF PRICING METHODOLOGY DIFFERENCES</u></b>	<b>27</b>
<b>15</b>	<b><u>SUMMARY</u></b>	<b>27</b>
	<b><u>APPENDIX A – STRUCTURE OF TRANSMISSION PRICING UNDER PART J OF RULES</u></b>	<b>28</b>
	<b><u>APPENDIX B – DETAILS OF COST ALLOCATION PROCESS</u></b>	<b>29</b>
	<b><u>APPENDIX C – COST REFLECTIVE NETWORK PRICING METHODOLOGY</u></b>	<b>31</b>
	Steps	31
	Allocation of Generation to Load	31
	Operating Conditions for Cost Allocation	31
	Load and generation data	32
	<b><u>APPENDIX D – MODIFIED LOAD EXPORT CHARGE COST REFLECTIVE NETWORK PRICING METHODOLOGY</u></b>	<b>33</b>
	Introduction	33
	Overview of the process	33
	Timetable for the provision of data	36
	Billing the modified load export charge	37
	Worked example – modified load export charge	37
	Step 1 – Aggregate annual revenue requirement (AARR)	37
	Step 2 – Annual service revenue requirement	38
	Step 3 – Adjustment for settlement residue auction proceeds	39
	Step 4 – Standard CRNP Calculation	39
	Step 5 – Modified load export charge to be recovered	40
	<b><u>APPENDIX E – PRIORITY ORDERING METHODOLOGY</u></b>	<b>41</b>
	Rules Requirements	41
	Objective and General Approach	42
	Methodology	42
	<b><u>Step 1: Branch Identification</u></b>	<b>42</b>
	<b><u>Step 2: Allocation of Circuit Breakers to Branches</u></b>	<b>42</b>
	<b><u>Step 3.1: Stand-alone arrangements for Prescribed TUOS</u></b>	<b>43</b>
	<b><u>Step 3.2: Stand-alone arrangements for Prescribed common transmission services</u></b>	<b>43</b>
	<b><u>Step 4: Allocation of substation infrastructure and establishment costs</u></b>	<b>43</b>
	Definition – Branches	44
	Examples	45

Formatted: Tab stops: 14.63 cm, Right



# Powerlink Pricing Methodology

<b>1</b>	<b>INTRODUCTION</b>	<b>1</b>	Formatted	... [1]
<b>2</b>	<b>INTERPRETATION</b>	<b>1</b>	Formatted	... [2]
<b>3</b>	<b>PRESCRIBED TRANSMISSION SERVICES</b>	<b>1</b>	Formatted	... [3]
<b>4</b>	<b>RULES REQUIREMENTS</b>	<b>2</b>	Formatted	... [4]
<b>5</b>	<b>PRICING METHODOLOGY GUIDELINES REQUIREMENTS</b>	<b>3</b>	Formatted	... [5]
<b>6</b>	<b>PRICING METHODOLOGY</b>	<b>5</b>	Formatted	... [6]
6.1	Background	5	Formatted	... [7]
6.2	Single Transmission Network Service Provider	5	Formatted	... [8]
6.3	Aggregate Annual Revenue Requirement (AARR)	6	Formatted	... [9]
6.4	Categories of transmission services	6	Formatted	... [10]
6.5	Cost allocation	7	Formatted	... [11]
6.6	Calculation of the attributable cost share for each category of service	8	Formatted	... [12]
6.7	Calculation of the Annual Service Revenue Requirement (ASRR)	9	Formatted	... [13]
6.8	Allocation of the ASRR to transmission network connection points	9	Formatted	... [14]
6.8.1	Prescribed entry services	9	Formatted	... [15]
6.8.2	Prescribed exit services	10	Formatted	... [16]
6.8.3	Prescribed Transmission Use of System (TUOS) services	11	Formatted	... [17]
6.8.3.1	Prescribed TUOS services – locational component	11	Formatted	... [18]
6.8.3.2	Prescribed TUOS services – non-locational component	12	Formatted	... [19]
6.9	Transmission prices and charges	13	Formatted	... [20]
6.9.1	Prescribed entry and exit services prices and charges	13	Formatted	... [21]
6.9.2	Prescribed TUOS services – locational component prices and charges	13	Formatted	... [22]
6.9.3	Prescribed TUOS services – non-locational component prices and charges	14	Formatted	... [23]
6.9.4	Prescribed common service prices and charges	15	Formatted	... [24]
6.10	System Strength Charges	17	Formatted	... [25]
6.10.1	Overview of the charging arrangements	17	Formatted	... [26]
6.10.2	System Strength Unit Price	18	Formatted	... [27]
6.11	Standby service arrangements	20	Formatted	... [28]
6.12	Excess demand charge	20	Formatted	... [29]
6.13	Setting of TUOS locational prices between annual price publications	21	Formatted	... [30]
<b>7</b>	<b>BILLING ARRANGEMENTS</b>	<b>22</b>	Formatted	... [31]
7.1	Billing for prescribed transmission services	22	Formatted	... [32]
7.2	Intra-Regional Payments between Transmission Network Service Providers	22	Formatted	... [33]
<b>8</b>	<b>PRUDENTIAL REQUIREMENTS</b>	<b>23</b>	Formatted	... [34]
8.1	Prudential requirements for prescribed transmission services	23	Formatted	... [35]
8.2	Capital contribution or prepayment for a specific asset	23	Formatted	... [36]

Formatted: Tab stops: 14.63 cm, Right



# Powerlink Pricing Methodology

<b>9</b>	<b>PRUDENT DISCOUNTS</b>	<b>23</b>	Formatted: Default Paragraph Font
<b>10</b>	<b>MONITORING AND COMPLIANCE</b>	<b>24</b>	Formatted: Default Paragraph Font
<b>11</b>	<b>NEW CONNECTIONS REQUIRING SIGNIFICANT INVESTMENT</b>	<b>24</b>	Formatted: Default Paragraph Font
11.1	Impact on TUOS locational prices in cases of significant investment.....	24	Formatted: Default Paragraph Font
11.2	Setting TUOS locational prices in the first year of significant investment.....	24	Formatted: Default Paragraph Font
<b>12</b>	<b>TRANSITIONAL ARRANGEMENTS TO IMPLEMENT THE PRICING METHODOLOGY</b>	<b>25</b>	Formatted: Default Paragraph Font
<b>13</b>	<b>ADDITIONAL INFORMATION REQUIREMENTS</b>	<b>25</b>	Formatted: Default Paragraph Font
<b>14</b>	<b>DESCRIPTION OF PRICING METHODOLOGY DIFFERENCES</b>	<b>26</b>	Formatted: Default Paragraph Font
<b>15</b>	<b>SUMMARY</b>	<b>26</b>	Formatted: Default Paragraph Font
<b>APPENDIX A – STRUCTURE OF TRANSMISSION PRICING UNDER PART J OF RULES</b>		<b>27</b>	Formatted: Default Paragraph Font
<b>APPENDIX B – DETAILS OF COST ALLOCATION PROCESS</b>		<b>28</b>	Formatted: Default Paragraph Font
<b>APPENDIX C – COST REFLECTIVE NETWORK PRICING METHODOLOGY</b>		<b>30</b>	Formatted: Default Paragraph Font
Steps 30			Formatted: Default Paragraph Font
	Allocation of Generation to Load.....	30	Formatted: Default Paragraph Font
	Operating Conditions for Cost Allocation.....	30	Formatted: Default Paragraph Font
	Load and generation data.....	31	Formatted: Default Paragraph Font
<b>APPENDIX D – MODIFIED LOAD EXPORT CHARGE COST REFLECTIVE NETWORK PRICING METHODOLOGY</b>		<b>32</b>	Formatted: Default Paragraph Font
	Introduction.....	32	Formatted: Default Paragraph Font
	Overview of the process.....	32	Formatted: Default Paragraph Font
	Timetable for the provision of data.....	35	Formatted: Default Paragraph Font
	Billing the modified load export charge.....	36	Formatted: Default Paragraph Font, Check spelling and grammar
	Worked example – modified load export charge.....	36	Formatted: Default Paragraph Font
	Step 1 – Aggregate annual revenue requirement (AARR).....	36	Formatted: Default Paragraph Font
	Step 2 – Annual service revenue requirement.....	37	Formatted: Default Paragraph Font
	Step 3 – Adjustment for settlement residue auction proceeds.....	38	Formatted: Default Paragraph Font
	Step 4 – Standard CRNP Calculation.....	38	Formatted: Default Paragraph Font
	Step 5 – Modified load export charge to be recovered.....	39	Formatted: Default Paragraph Font
<b>APPENDIX E – PRIORITY ORDERING METHODOLOGY</b>		<b>40</b>	Formatted: Default Paragraph Font
	Rules Requirements.....	40	Formatted: Default Paragraph Font
	Objective and General Approach.....	41	Formatted: Default Paragraph Font
	Methodology.....	41	Formatted: Default Paragraph Font
	Step 1: Branch Identification.....	41	Formatted: Default Paragraph Font
			Formatted: Tab stops: 14.63 cm, Right



# Powerlink Pricing Methodology

~~Step 2: Allocation of Circuit Breakers to Branches .....41~~  
~~Step 3.1: Stand alone arrangements for Prescribed TUOS.....41~~  
~~Step 3.2: Stand alone arrangements for Prescribed common transmission services .....42~~  
~~Step 4: Allocation of substation infrastructure and establishment costs.....42~~  
~~Definition – Branches.....43~~  
~~Examples .....44~~

**Formatted:** Default Paragraph Font, Font: Not Bold, Check spelling and grammar

**Formatted:** Default Paragraph Font, Font: Not Bold, Check spelling and grammar

**Formatted:** Default Paragraph Font, Font: Not Bold, Check spelling and grammar

**Formatted:** Default Paragraph Font, Font: Not Bold, Check spelling and grammar

**Formatted:** Default Paragraph Font

**Formatted:** Default Paragraph Font

**Formatted:** Tab stops: 14.63 cm, Right





# Powerlink Pricing Methodology

## 1 INTRODUCTION

Powerlink is the principal electricity *Transmission Network Service Provider (TNSP)* and *System Strength Service Provider* in Queensland.

This *pricing methodology* ~~for the regulatory period will apply~~ from 1 July ~~2022~~2023 to 30 June 2027 ~~will be proposed and proposes amendments~~ to the ~~Australian Energy Regulator (AER) previous pricing methodology to address the changes required by the introduction of System Strength Charging~~ in accordance ~~with the AEMC's Rule determination, Efficient Management of System Strength on the Power System Rule 2021, October 2021.~~ This *pricing methodology* ~~complies~~ with the requirements of Chapter 6A of the National Electricity Rules (the Rules) and the AER's pricing methodology guidelines<sup>1</sup>.

## 2 INTERPRETATION

All terms in this *pricing methodology* that are italicised have the meaning given to them in the *pricing methodology guidelines* or, where no definition is provided in that document, the Rules ~~or this pricing methodology~~.

A reference to the Rules is taken to be a reference to the ~~current version of the~~ National Electricity Rules, version ~~174188~~, which commenced operation on ~~129~~ September ~~2021 as amended from time to time~~2022.

## 3 PRESCRIBED TRANSMISSION SERVICES

Powerlink's *pricing methodology* relates to the provision of *prescribed transmission services* in the Queensland region by Powerlink. These services include:

- Shared transmission services provided to customers directly connected to the transmission network and connected network service providers (*prescribed TUOS services*);
- Connection services provided to connect the distribution networks such as Ergon Energy and Energex to the transmission network (*prescribed exit services*);
- Grandfathered connection services provided to generators and customers directly connected to the transmission network for connections that were in place or committed to be in place on 9 February 2006 (*prescribed entry services* and *prescribed exit services*); ~~and~~
- Services required under the Rules or in accordance with jurisdictional electricity legislation that are necessary to ensure the integrity of the transmission network, including the maintenance of power system security and assisting in the planning of

<sup>1</sup> AER, Electricity transmission network service providers Pricing methodology guidelines (~~17 July 2014~~, ~~25 August 2022~~).



# Powerlink Pricing Methodology

Formatted: Font: 8 pt, Font color: Auto

the power system (*prescribed common transmission services*), other than *system strength transmission services*; and

- *System strength transmission services, which is the provision of facilities or services to meet the standard in clause S5.1.14 at system strength nodes. System strength transmission services are classified as prescribed common transmission services.*

Powerlink's *pricing methodology* does not relate to the provision of *negotiated transmission services* or other *transmission services* provided by Powerlink (non-regulated transmission services) that are not subject to economic regulation under the Rules.

## 4 RULES REQUIREMENTS

Clause 6A.24.1(b) states that a *pricing methodology* is a methodology, formula, process or approach that, when applied by a *TNSP* or *Co-ordinating Network Service Providers (CNSP)* on behalf of *TNSPs* within a region:

- (1) allocates the *aggregate annual revenue requirement* for *prescribed transmission services* provided by the *Transmission Network Service Provider* to each *category of prescribed transmission services*;
- (2) provides for the manner and sequence of adjustments to the *annual service revenue requirement*;
- (3) allocates the *annual service revenue requirement* to *transmission network connection points* (other than *connection points* of any *Market Network Service Provider*); and
- (4) determines the structure and recovery of prices for each *category of prescribed transmission services* under clause 6A.23.4(a).

Clause 6A.24.1(b1) also requires that in addition to complying with any other requirements within Chapter 6A, the *pricing methodology* of a *TNSP* that is the *CNSP* for a region must provide for:

- (1) the allocation of the *AARR* for *prescribed transmission services* provided by *Transmission Network Service Providers* within that *region*, including any allocation of the *AARR* as agreed between *Transmission Network Service Providers* in accordance with clause 6A.29.3;
- (2) the calculation of *modified load export charges* consistent with clause 6A.29A.2;
- (3) the allocation and billing of *modified load export charges*:
  - (i) receivable by other *Co-ordinating Network Service Providers* in *interconnected regions*; and
  - (ii) payable to other *Co-ordinating Network Service Providers* in *interconnected regions*,



## Powerlink Pricing Methodology

to each Transmission Network Service Provider within its region under clause 6A.29A.5; and

- (4) the allocation of proceeds from *auctions* or a portion of *settlements residue* receivable by or payable to the *Transmission Network Service Provider* in its *region* as referred to in clause 6A.23.3(b)(1).

Formatted: Font: 8 pt, Font color: Auto



## Powerlink Pricing Methodology

The Rules also require that the *pricing methodology* satisfy principles and guidelines established by the Rules. In particular, clause 6A.10.1(e) requires that a *-pricing methodology* must:

- (1) give effect to and be consistent with the *Pricing Principles for Prescribed Transmission Services*. That is, the principles set out in clause 6A.23; and
- (2) comply with the requirements of, and contain or be accompanied by such information as is required by the *pricing methodology guidelines* made for that purpose under clause 6A.25.

### 5 PRICING METHODOLOGY GUIDELINES REQUIREMENTS

The *pricing methodology guidelines* supplement and elaborate on the pricing principles contained in Chapter 6A of the Rules in so far as they specify or clarify:

- the information that is to accompany a *pricing methodology*;
- permitted pricing structures for the recovery of the locational component of *prescribed TUOS services*;
- permitted postage stamp pricing structures for the recovery of the adjusted non-locational component of *prescribed TUOS services* and *prescribed common transmission services*;
- the types of *transmission system* assets that are *directly attributable* to each category of *prescribed transmission services*; ~~and~~
- the permitted methodologies for determining the system strength unit price component of the system strength charge;
- principles for determining forecast annual system strength revenue and estimated actual annual system strength revenue; and
- the parts of a *pricing methodology*, or the information accompanying it that will not be publicly disclosed without the consent of the *TNSP*.

All key elements of Powerlink's *pricing methodology* are permissible under the *pricing methodology guidelines*. These elements include:

- calculation of the locational component of *prescribed TUOS services* costs using the *cost reflective network pricing methodology*;
- the locational *prescribed TUOS services* price being based on *contract agreed maximum demand* or an agreed nominated demand and the average-half hourly demand;
- the postage stamp pricing structures for the non-locational component of *prescribed TUOS services* and *prescribed common transmission services* being based on *contract agreed maximum demand* or historical energy;



## Powerlink Pricing Methodology

Formatted: Font: 8 pt, Font color: Auto

- the methodology for setting the system strength unit price based on long run average costs, covering a 10 year period, at each system strength node and the basis for applying an annual indexation to the system strength unit price;
- the methodology for forecasting or estimating annual system strength revenues;
- the methodology for implementation of the priority ordering being the priority ordering approach under clause 6A.23.2(d);
- a description of how asset costs which may be attributable to both *prescribed entry services* and *prescribed exit services* will be allocated at a connection point;
- a description of billing arrangements under clause 6A.27;
- a description of prudential requirements as outlined in clause 6A.28;
- a description of how modified load export charges are calculated under clause 6A.29A;
- the inclusion of hypothetical worked examples; and
- a description of how Powerlink intends to monitor and develop records of its compliance with its approved *pricing methodology*, the pricing principles for *prescribed transmission services* (clause 6A.23) and part J of the Rules in general.



# Powerlink Pricing Methodology

Formatted: Font: 8 pt, Font color: Auto

## 6 PRICING METHODOLOGY

### 6.1 Background

Powerlink's *pricing methodology* includes amendments to the previous *pricing methodology* approved by the AER in April ~~2017~~2022 to:

- ~~phase out~~include a methodology for determining the average demandsystem strength unit price component used inof the calculation of locational prices;system strength charge; and
- include an adjustment to the non-locational component of *Prescribed TUOS services* methodology for advised *NTP function fees*;
- include an additional reference in the Rules regarding the calculation of payments between multiple *Transmission Network Service Providers* in Queensland;
- clarify the application of excess demand charges;
- clarify consistency with the AER Pricing Methodology Guidelines regarding postage stamped pricesdetermining forecast *annual system strength revenue* and prudent discounts; and
- clarify the publication date of the Modified Load Export Chargeestimated *actual annual system strength revenue*.

The diagram in Appendix A outlines the structure of transmission pricing under part J of the Rules that is applicable to this *pricing methodology*.

### 6.2 Single Transmission Network Service Provider

Powerlink is the sole provider of *prescribed transmission services* within Queensland and is responsible for the allocation of the *AARR* within Queensland, in accordance with clause 6A.29.2.

Therefore, consistent with clause 6A.29A.1 where there is only one *Transmission Network Service Provider* of *prescribed transmission services* within a region, references within the Rules to a *Co-ordinating Network Service Provider* is to be read as a reference to that *Transmission Network Service Provider*.

In the event that *prescribed transmission services* within Queensland are provided by more than one *Transmission Network Service Provider* and Powerlink is appointed as the *Co-ordinating Network Service Provider*, revenues will be allocated and collected for any other *Transmission Network Service Provider* in accordance with clause 6A.29.1.

Under this arrangement the *Co-ordinating Network Service Provider* is responsible for:

- (1) the allocation of all relevant *AARR* within that *region*, including any allocation of the *AARR* as agreed between *Transmission Network Service Providers* in accordance with clause 6A.29.3;



## Powerlink Pricing Methodology

Formatted: Font: 8 pt, Font color: Auto

- (2) the calculation of *modified load export charges* and any adjustments to the charges in accordance with the *Rules* payable by *Co-ordinating Network Service Providers* in *interconnected regions*; and
- (3) the allocation of *modified load export charges* and any adjustments to the charges in accordance with the *Rules* payable or receivable to or from *Co-ordinating Network Service Providers* in *interconnected regions* to each *Transmission Network Service Provider* within its *region*.

### 6.3 Aggregate Annual Revenue Requirement (AARR)

The revenue that a *TNSP* may earn in any *regulatory year* of a *regulatory control period* from the provision of *prescribed transmission services* is known as the *maximum allowed revenue*<sup>2</sup>.

The *AARR* is calculated in accordance with clause 6A.22.1 as:

the *maximum allowed revenue* referred to in clause 6A.3.1 adjusted:

- (1) in accordance with clause 6A.3.2,
- (2) by subtracting the operating and maintenance costs expected to be incurred in the provision of *prescribed transmission services*; ~~and~~ and expected system strength service payments; and
- (3) by any allocation as agreed between *Transmission Network Service Providers* in accordance with clause 6A.29A.3.

Adjustments in accordance with clause 6A.3.2 could relate to a number of factors including reopening of the revenue determination for capital expenditure, network support pass through, cost pass through, service target performance incentive scheme outcomes, contingent projects or impacts due to wrong information or error.

The costs referred to in (2) above are derived from budget projections and include:

- network switching and operations;
- administration and management of the business;
- network planning and development; and
- general overheads.

### 6.4 Categories of transmission services

Powerlink's *AARR* is recovered from transmission charges for the following categories of *prescribed transmission services*:

- **Prescribed entry services**, are entry services that are *prescribed transmission services* by virtue of the operation of clause 11.6.11 which include assets that are

<sup>2</sup> Clause 6A.3.1



## Powerlink Pricing Methodology

Formatted: Font: 8 pt, Font color: Auto

directly attributable to serving a Generator or group of Generators at a single connection point;

- **Prescribed exit services**, which include assets that are directly attributable to serving a *Transmission Customer* or group of *Transmission Customers* at a single connection point and: (a) are deemed prescribed by virtue of the operation of clause 11.6.11; or (b) are provided to Distribution Network Service Providers at the boundary of the prescribed transmission network;
- **Prescribed common transmission services**, which are services that provide equivalent benefits to all *Transmission Customers* without any differentiation based on their location, and therefore cannot be reasonably allocated on a locational basis; ~~and~~ These services include system strength transmission services, which are the provision of facilities or services to meet the standard in clause S5.1.14 at system strength nodes.
- **Prescribed TUOS services**, which include services that provide benefits to *Transmission Customers* depending on their location within the transmission system, that are shared to a greater or lesser extent by all users across the *transmission system* and are not *prescribed common transmission services, prescribed entry services or prescribed exit services*.

The determination of prescribed transmission service prices involves four steps:

- (1) allocation of the costs of transmission system assets to the categories of transmission service, to the extent to which assets are directly attributable to the provision of a *category of prescribed transmission services* (see section 6.5);
- (2) calculation of the *attributable cost shares* (see section 6.6);
- (3) allocation of the *AARR* to each category of *prescribed transmission services* in accordance with the attributable cost share for that category of services (see section 6.7); and
- (4) allocation of the *annual service revenue requirement (ASRR)* for *prescribed entry services, prescribed exit services and prescribed TUOS services* to each transmission network connection point in accordance with the principles of clause 6A.23.3 (see section 6.8).

Each step is described in further detail below.

### 6.5 Cost allocation

The **first step** in calculating prescribed transmission service prices is to allocate the costs of *transmission system* assets to the categories of transmission service in section 6.4 above, to the extent to which assets are *directly attributable* to the provision of a *category of prescribed transmission services*.





# Powerlink Pricing Methodology

Formatted: Font: 8 pt, Font color: Auto

The delineation between the assets that provide *prescribed entry services*, *prescribed exit services*, *prescribed TUOS services* and *prescribed common transmission services* is set out in clause 2.4 of the *pricing methodology guidelines*.

Powerlink’s cost allocation process assigns the optimised replacement cost (ORC)<sup>3</sup> of all *prescribed transmission services* assets to individual network pricing branches. Each network pricing branch is then defined as common, connection (entry or exit) or shared network. The pricing branches are used to determine the costs of the *transmission system* assets directly attributable to each *category of prescribed transmission services*, as required under Chapter 6A of the Rules. This cost allocation process is explained in more detail in Appendix B.

## 6.6 Calculation of the attributable cost share for each category of service

The **second step** in calculating prescribed transmission service prices is the calculation of the *attributable cost shares*. The *attributable cost share* for each *category of prescribed transmission services* is calculated in accordance with clause 6A.22.3, as the ratio of:

- (1) the costs of the *transmission system* assets directly attributable to the provision of that *category of prescribed transmission services*; to
- (2) the total costs of all of Powerlink’s *transmission system* assets directly attributable to the provision of *prescribed transmission services*,

where these amounts are determined as detailed in section 6.5 above.

For example, if the ORC of prescribed services assets have been allocated to the applicable categories of *prescribed transmission services* as shown in [Table 1](#) then the *attributable costs shares* are calculated as shown in the hypothetical example below. All numbers and amounts used in the hypothetical examples in the paper are fictional!

$$\begin{aligned}
 \text{Attributable cost share}_{\text{EXIT}} &= \text{ORC}_{\text{EXIT}} / \text{ORC}_{\text{TOTAL}} \\
 &= \$6,972,222 / \$43,050,000 \\
 &= 0.162
 \end{aligned}$$

with the *attributable cost shares* of the other categories calculated in the same manner, as shown in Table 2.

**Table 1: Hypothetical costs allocated to categories of prescribed transmission services**

Category	ORC
Exit service	6,972,222
Entry service	1,761,111
TUOS service	33,566,667
Common Service	750,000
<b>Total</b>	<b>43,050,000</b>

<sup>3</sup> Consistent with clause 6A.22.3(b).



# Powerlink Pricing Methodology

Formatted: Font: 8 pt, Font color: Auto

Table 2: Hypothetical attributable cost shares

Category	ORC	Attributable cost share
Exit service	6,972,222	0.162
Entry service	1,761,111	0.041
TUOS service	33,566,667	0.780
Common Service	750,000	0.017
Total	43,050,000	1.000

## 6.7 Calculation of the Annual Service Revenue Requirement (ASRR)

The **third step** in calculating prescribed transmission service prices is to allocate the *AARR* to each *category of prescribed transmission services* in accordance with the *attributable cost share* for that category of service.

This allocation results in the *ASRR* for each *category of prescribed transmission services*.

Assuming an *AARR* of \$2,504,434 and applying the *attributable cost shares* determined above, the *ASRR* for each category of prescribed service is calculated as:

$$\begin{aligned} ASRR_{\text{EXIT}} &= AARR \times \text{Attributable cost share}_{\text{EXIT}} \\ &= \$2,504,434 \times 0.162 \\ &= \$405,609 \end{aligned}$$

with the *ASRRs* of the other categories calculated in the same manner.

Table 3: Hypothetical Annual Service Revenue Requirements

Category	Attributable cost share	Annual Service Revenue Requirement (ASRR)
Exit service	0.162	405,609
Entry service	0.041	102,453
TUOS service	0.780	1,952,741
Common Service	0.017	43,631
Total	1.000	2,504,434

## 6.8 Allocation of the ASRR to transmission network connection points

The **fourth step** in calculating prescribed transmission service prices is to allocate the *ASRR* for *prescribed entry services*, *prescribed exit services* and *prescribed TUOS services* to each transmission network connection point in accordance with the principles of clause 6A.23.3.



# Powerlink Pricing Methodology

Formatted: Font: 8 pt, Font color: Auto

## 6.8.1 Prescribed entry services

The whole of the ASRR for *prescribed entry services* is allocated to each transmission network connection point in accordance with the *attributable connection point cost share* for *prescribed entry services* that are provided by the TNSP at that connection point.

The *attributable connection point cost share* for *prescribed entry services* is the ratio of the costs of the *transmission system assets directly attributable* to the provision of *prescribed entry services* at that transmission network connection point to the total costs of all the TNSP's *transmission system assets directly attributable* to the provision of *prescribed entry services*.

For example, if two generators, Gen A1 and Gen A2 receive *prescribed entry services* and the cost allocation process has allocated the ORC of assets *directly attributable to prescribed entry services* to them as shown in Table 4.

$$\begin{aligned} \text{Attributable connection point cost share}_{\text{GEN A1}} &= \text{ORC}_{\text{GEN A1}} / \text{ORC}_{\text{ENTRY}} \\ &= \$1,033,333 / \$1,761,111 \\ &= 0.587 \end{aligned}$$

with the *attributable connection point cost share* of the other generator being calculated in the same manner as shown in Table 5.

**Table 4: Hypothetical prescribed entry services ORC**

Entry	ORC
Gen A1	1,033,333
Gen A2	727,778
Total ORC of prescribed entry assets	1,761,111

**Table 5: Hypothetical attributable connection point cost shares**

Entry	ORC	Attributable connection point cost share
Gen A1	1,033,333	0.587
Gen A2	727,778	0.413
Total	1,761,111	1.000

The ASRR allocated to the Gen A1 transmission network connection point is calculated as follows:

$$\begin{aligned} \text{ASRR}_{\text{GEN A1}} &= \text{ASRR}_{\text{ENTRY}} \times \text{Attributable connection point cost share}_{\text{GEN A1}} \\ &= \$102,453 \times 0.587 \\ &= \$60,114 \end{aligned}$$



## Powerlink Pricing Methodology

Formatted: Font: 8 pt, Font color: Auto

with the ASRR of the other generator connection point being calculated in the same manner.

Table 6: Hypothetical connection point ASRRs (entry)

Entry	ORC	Attributable connection point cost share	Connection point ASRR
Gen A1	1,033,333	0.587	60,114
Gen A2	727,778	0.413	42,338
Total	1,761,111	1.000	102,453

### 6.8.2 Prescribed exit services

The whole of the ASRR for *prescribed exit services* is allocated to each transmission network connection point in accordance with the *attributable connection point cost share* for *prescribed exit services* that are provided by the TNSP at that connection point.

The *attributable connection point cost share* for *prescribed exit services* is the ratio of the costs of the *transmission system assets directly attributable* to the provision of *prescribed exit services* at that transmission network connection point to the total costs of all the *transmission system assets directly attributable* to the provision of *prescribed exit services*.

The ASRRs of the prescribed exit connection points are calculated in the same manner as for the prescribed entry connection points.

Table 7: Hypothetical Connection point ASRRs (exit)

Exit	ORC	Attributable connection point cost share	Connection point ASRR
Load A1	2,083,333	0.299	121,198
Load A2	1,405,556	0.202	81,768
Load B1	2,633,333	0.378	153,194
Load C1	850,000	0.122	49,449
Total	6,972,222	1.000	405,609

### 6.8.3 Prescribed Transmission Use of System (TUOS) services

The prescribed TUOS (shared network) services ASRR is recovered from:

- *Prescribed TUOS services* (locational component); and
- *Prescribed TUOS services* (the adjusted non-locational component).

Clause 6A.23.3(a) requires that the *annual service revenue requirement* for *prescribed TUOS services* is to be allocated between a locational component (*pre-adjusted locational component*) and a non-locational component (*pre-adjusted non-locational component*) either:

- (1) as 50% to each component; or



## Powerlink Pricing Methodology

Formatted: Font: 8 pt, Font color: Auto

- (2) an alternative allocation to each component, that is based on a reasonable estimate of future network utilisation and the likely need for future transmission investment, and that has the objective of providing more efficient locational signals to *Market Participants, Intending Participants* and end users.

### 6.8.3.1 Prescribed TUOS services – locational component

Consistent with clause 6A.23.3(b) to (d), the locational share of the *prescribed TUOS services ASRR* is adjusted by:

- subtracting any amount estimated as proceeds from *auctions* or any portion of *settlements residue* allocated to the *directional interconnector* which is not the subject of a *SRD agreement* estimated to be receivable by the *Transmission Network Service Provider* from the *connection points* for each relevant *directional interconnector* as referred to in clause 3.18.4, with that amount including an adjustment calculated in accordance with paragraph 6A.23.3(f); and
- adding or subtracting the estimated modified load export charge (MLEC) determined by the *CNSP* in accordance with clause 6A.29A of the Rules. This adjustment is calculated in accordance with 6A.23.3(f); and
- If the *adjusted locational component* is a positive amount, it is to be allocated to *transmission network connection points* of *Transmission Customers* on the basis of their proportionate use of the relevant *transmission system* asset using the *CRNP methodology* to estimate the proportionate use of the relevant *transmission system* assets (clause 6A.23.3(c)); and
- If the *adjusted locational component* is a negative amount, then the *adjusted locational component* will be deemed to be zero and the absolute value of that negative amount is to be subtracted from the *pre-adjusted non-locational component* (clause 6A.23.3(d)).

The *CRNP methodology* allocates shared network costs to individual customer connection points on the basis of optimised replacement costs and assumes a 50 - 50 split between the locational and non-locational components of network charges.

Powerlink applies the *CRNP methodology* using the *TPRICE cost reflective network pricing* software approved by the AER for use by *TNSPs* in the NEM to calculate intra-regional charges.

The *CRNP methodology* requires three sets of input data:

- an electrical (loadflow) model of the network;
- a cost model of the network (the results of the cost allocation process described in Appendix B); and
- an appropriate set of load/ generation patterns.

Appendix C describes the *CRNP methodology* in more detail.



# Powerlink Pricing Methodology

Formatted: Font: 8 pt, Font color: Auto

Appendix D describes the MLEC *CRNP methodology* in more detail.

## 6.8.3.2 Prescribed TUOS services – non- locational component

The remainder of the *ASRR* (the pre-adjusted non-locational component) is adjusted in accordance with clause 6A.23.3(e) of the Rules by:

- subtracting the absolute value of any negative adjusted locational component (referred to above); and
- by adding or subtracting any remaining *settlements residue* (not being *settlements residue* referred to in the determination of the locational component or *settlements residue* that accrue on a *designated network asset* due to *boundary point loss factors*, but otherwise including the portion of *settlements residue* due to *intra-regional loss factors*) which is expected to be distributed or recovered (as the case may be) to or from the *TNSP* in accordance with clause 3.6.5(a); and
- for any over-recovery amount or under-recovery amount from previous years including an adjustment in accordance with 6A.23.3(f)<sup>4</sup>; and
- for any shortfall or over-recovery that arises from limiting the change in locational prices at a connection point (clause 6A.23.4(c) and (d)); and
- for any amount arising as a result of the application of prudent discounts in accordance with clause 6A.26.1(d) to (g); and
- adding the amount of *NTP function* fees advised in accordance with clause 2.11.3(ba), outlined in clause 6A.23.3(e)(6).

## 6.9 Transmission prices and charges

### 6.9.1 Prescribed entry and exit services prices and charges

*Prescribed entry services* and *prescribed exit services* prices are calculated to recover the *prescribed entry and prescribed exit services ASRRs* from the network users who are served by the relevant connection assets.

The *prescribed entry services ASRR* is recovered as a fixed annual charge for each entry point, which is recovered on the basis of a fixed \$/month entry price.

Similarly, the *prescribed exit services ASRR* is recovered as a annual monthly charge for each exit point, which is recovered on the basis of a fixed \$/month exit price.

<sup>4</sup> The difference between budget estimates and actual amounts in the settlement residue auction proceeds (clause 6A.23.3(b)(1)), the modified load export charge (MLEC) (clause 6A.23.3(b)(2)), and the under and over recovery amounts (clause 6A.23.3(e)(5)) are to be adjusted in accordance clause 6A.23.3(f) of the Rules.



## Powerlink Pricing Methodology

Formatted: Font: 8 pt, Font color: Auto

### 6.9.2 Prescribed TUOS services – locational component prices and charges

References to percentages in this section are subject to transitional arrangements outlined in section 12.

The prescribed TUOS locational ASRR described in section 6.8.3 is recovered through a single demand based price at each connection point. The price is based on the sum of the relevant percentage of the average half-hourly demand and the agreed nominated demand or *contract agreed maximum demand*, reflecting the greatest utilisation of the *transmission network* and times for which network investment is most likely to be contemplated, in accordance with clause 6A.23.4(b)(1) and 2.2(a) of the *pricing methodology guidelines*.

The CRNP methodology outlined in Schedule 6A.3 of the Rules and detailed in Appendix C of this *pricing methodology* describes the process for cost allocation for the locational component of *prescribed TUOS services*, which results in a lump sum dollar amount to be recovered at each connection point.

This lump sum dollar amount for each connection point is divided by the sum of the relevant percentage of the average half hourly demand and the agreed nominated demand or *contract agreed maximum demand*, and then divided by twelve to calculate the monthly locational price for that particular connection point<sup>5</sup>. Prices for *prescribed TUOS services* are expressed in \$/kW/month.

As provided for under clause 6A.23.4(b)(2), TUOS locational prices must not change by more than 2% per annum at connection points relative to the load weighted average TUOS locational price for the region. The balance of any revenue shortfall or over recovery resulting from these price caps is recovered, or offset as appropriate, by adjusting TUOS non-locational prices and charges in accordance with clauses 6A.23.4(c) and 6A.23.4(d).

The prices related to this locational component are not subject to this limitation if:

- to the extent that the change in prices relate to the adjusted MLEC as per clause 6A.23.4(b)(3)(i); or
- as per clause 6A.23.4(b)(3)(ii), if since the commencement of the previous regulatory year:
  - (A) the load at the connection point has materially changed;
  - (B) in connection with that change, the Transmission Customer requested a renegotiation of its connection agreement with the Transmission Network Service Provider; and
  - (C) the AER has approved the change of more than 2 per cent per annum.

Prescribed TUOS locational charges are determined, for each connection point providing *prescribed TUOS services* by multiplying the prescribed TUOS locational price by the sum of

<sup>5</sup> The connection point for the purposes of determining the prescribed TUOS prices and prescribed TUOS charges will be the agreed point (or points) of supply between Powerlink and the transmission network user.



## Powerlink Pricing Methodology

Formatted: Font: 8 pt, Font color: Auto

the agreed nominated demand (prevailing at the time transmission prices are published) and the relevant percentage of the measured average half-hourly demand for that month for that connection point, in accordance with 2.2(h) of the *pricing methodology guidelines*.

### 6.9.3 Prescribed TUOS services – non-locational component prices and charges

Prices for recovery of the adjusted non-locational component of *prescribed TUOS services* are set on a postage stamp basis in accordance with clause 6A.23.4(e).

Consistent with the provisions of 2.3(c)(1) of the *pricing methodology guidelines* postage stamped prices are determined on the basis of *contract agreed maximum demand* or historical energy and are calculated annually as follows.

Each financial year Powerlink will determine the following two prices to apply at every connection point:

- an energy based price that is a price per unit of historical metered energy or current metered energy at a connection point expressed as c/kWh; and
- a *contract agreed maximum demand* price that is a price per unit of *contract agreed maximum demand* at a connection point expressed as \$/kW/month.

Either the energy based price or the *contract agreed maximum demand* price will apply at a connection point providing *prescribed TUOS services* except for those connection points where a transmission customer has negotiated reduced charges for the adjusted non-locational component of *prescribed TUOS services* in accordance with clause 6A.26 (prudent discounts).

The energy based price and the *contract agreed maximum demand* price is determined so that:

- a transmission customer with a load factor in relation to its connection point equal to the median load factor for connection points with transmission customers connected to the transmission network in the region or regions is indifferent between the use of the energy based price and the *contract agreed maximum demand* price; and
- the total amount to be recovered by the adjusted non-locational component of *prescribed TUOS services* does not exceed the ASRR for this category of *prescribed transmission service*.

When applying the energy based price, the prescribed TUOS charge (non-locational component) for a billing period is calculated for each connection point by:

- multiplying the energy based price by the metered energy offtake at that connection point in the corresponding billing period two years earlier (i.e. *historical metered energy offtake*); or
- multiplying the energy based price by the metered energy offtake at that connection point in the same billing period (*current metered energy offtake*) if the *historical metered energy offtake* is unavailable; or





## Powerlink Pricing Methodology

- multiplying the energy based price by the *current metered energy offtake* if the *historical metered energy offtake* is significantly different to the *current metered energy offtake*. This method of calculation is only expected to be applied where the conditions necessary to enact clause 6A.23.4(b)(3)(ii)<sup>6</sup> have been satisfied or a connection point is operated in a standby arrangement as detailed in section ~~6.116-4011~~ of this *pricing methodology*.

Formatted: Font: 8 pt, Font color: Auto

When applying the *contract agreed maximum demand* price, the prescribed TUOS – non-locational component charge for a billing period will be calculated for each connection point by multiplying the *contract agreed maximum demand* price by the *contract agreed maximum demand* for the *connection point* (prevailing during the billing period concerned).

Forecast prescribed TUOS non-locational charges will be calculated using the *contract agreed maximum demand* prevailing at the time prices are determined as distinct from the actual *contract agreed maximum demand* based charges which will be calculated using the *contract agreed maximum demand* prevailing during the billing period concerned.

Any over or under recovery of prescribed revenue arising from variances between forecast *contract agreed maximum demands* and the *contract agreed maximum demands* used for calculating charges will be addressed by way of an under or over recovery adjustment when calculating prices for the following financial year.

The energy based price or the *contract agreed maximum demand price* that applies for the *adjusted non-locational component of prescribed TUOS services* at a connection point will be the one which results in the lower estimated charge for that *prescribed transmission service*.

### 6.9.4 Prescribed common service prices and charges

Prices for *prescribed common transmission services* are set on a postage stamp basis in accordance with clause 6A.23.4(f) and 6A.23.4(h).

Consistent with the provisions of clause 2.3(c)(1) of the *pricing methodology guidelines* postage stamped prices will be determined on the basis of *contract agreed maximum demand* or historical energy and calculated in a manner identical to that described for TUOS non-locational charges in the previous section.

In accordance with clause 6A.23.3(h) the operating and maintenance costs expected to be incurred in the provision of *prescribed common transmission services and expected system strength service payments*, which are deducted from the *maximum allowed revenue* to form the AARR, are added to the ASRR for *prescribed common transmission services* and recovered through *prescribed common service prices and charges*.

In accordance with clause 6A.23.3(h1), in addition to the adjustment under paragraph (h), the ASRR for prescribed common transmission services must be adjusted by subtracting the forecast annual system strength revenue for the regulatory year and any adjustment for under

Formatted: Keep with next

<sup>6</sup> That being the clause which allows for the relaxation of the side constraints on TUOS locational prices at a connection point.



## Powerlink Pricing Methodology

Formatted: Font: 8 pt, Font color: Auto

or over recovery from previous years, calculated in accordance with clause 6A.23.3A(b). These adjustments enable:

- Revenue from *system strength charges* to be recovered from *System Strength Transmission Service Users* in accordance with section 6.10 of this pricing methodology;
- Any residual annual costs in providing *system strength services* that are not forecast to be recovered from *system strength charges* to be recovered from all *Transmission Customers* through *common service charges*. These services provide equivalent benefits to all Transmission Customers without any differentiation based on their location; and
- Any under- or over-recovery in relation to *annual system strength revenue* for years  $t-1$  and  $t-2$  to be corrected by adjusting the *annual service revenue requirement* for prescribed common transmission services for year  $t$ .

To give effect to clauses 6A.23.3(h1) and 6A.23.3A(a)(1) and (2), we will forecast the *annual system strength revenue* for year  $t$  and the estimate of the actual *annual system strength revenue* for year  $t-1$ . While our forecasting methodology will change in light of new information and experience, it will comply with the following principles specified in paragraphs 2.1(k)(7), 2.1(k)(8) and 2.8 of the AER's *pricing methodology guidelines*:

- (1) the methodologies will be reasonable and appropriate for their purpose;
- (2) the cost of implementing the methodologies will be proportionate to the expected level of materiality of the impact of any inaccuracy in estimates or forecasts;
- (3) the methodologies will utilise relevant existing information to the extent possible, including information from *connection agreements* and, where relevant, applications to connect;
- (4) the methodologies will be consistent with any relevant parts of the *system strength requirements methodology* and *system strength impact assessment guidelines*;
- (5) the methodologies will be consistent with other relevant parts of the *pricing methodology* and our approach to other relevant forecasts or estimates; and
- (6) -estimated actual annual system strength revenue will be based on actual data for part of the regulatory year where actual data is available and updated forecasts for the remainder of the regulatory year.

For the purpose of this *pricing methodology*, which covers the first *system strength charging period*, it is noted that:

- There is limited historical data that could inform our forecast revenue from *system strength charges*; and



# Powerlink Pricing Methodology

Formatted: Font: 8 pt, Font color: Auto

- There is no information available regarding the likelihood that connection applicants will elect to pay the *system strength charge* in relation to the proposed *connection or alteration*.

Given the limited historical data, our methodology for forecasting the annual revenue from *system strength charges* will have regard to the following information:

- actual contracts for the provision of *system strength services* for the relevant year;
- forecast new connections for the relevant year having regard to known connection enquiries and connection applications;
- forecast of the new connections that will elect to pay the *system strength charge*, having regard to the facility seeking or likely to seek connection and an estimate of the costs of self-remediation; and
- the estimated applicable *system strength unit prices*; *system strength locational factors*; and *system strength quantity* applicable to each actual and forecast contract for the provision of *system strength services*.

Our forecasting method will be reviewed and updated as historical data becomes available. Over time, an increasing proportion of our *system strength charges* will be obtained from existing connections, rather than new connections. As a result, the accuracy of our revenue forecasts will tend to improve in future regulatory periods.

## 6.10 System Strength Charges

The charging arrangements described in this section satisfy the requirements of clause 6A.23.5 of the Rules and paragraph 2.7 of the AER's *pricing methodology guidelines*.

### 6.10.1 Overview of the charging arrangements

The *System Strength Transmission Service User* for a system strength connection point must pay an *annual system strength charge* for the *system strength connection point* calculated in accordance with this section 6.10. The *annual system strength charge* is payable in equal monthly instalments. *System strength charges* come into effect from 1 July 2023.

If the obligation to pay the *system strength charge* in relation to a *system strength connection point* commences part way through a *regulatory year*, the *annual system strength charge* will be calculated on a pro rata basis and charged for the remaining months of the regulatory year.

The *annual system strength charge* for a *system strength connection point* for a *regulatory year* will be calculated in accordance with the following formula:

$$\text{SSC} = \text{SSUP} \times \text{SSL} \times \text{SSQ}$$

where:

SSC is the *annual system strength charge* for the regulatory year (in \$).

Revised Proposed Pricing Methodology Revised Proposed Amended Pricing

Methodology

4756

**ANY PRINTED COPY OF THIS DOCUMENT IS UNCONTROLLED**



# Powerlink Pricing Methodology

Formatted: Font: 8 pt, Font color: Auto

**SSUP** is the *system strength unit price* for the *system strength node*. SSUP will be the same for each *regulatory year* in a *system strength charging period*, except to the extent the *pricing methodology guidelines* permit indexation, in accordance with clause 6A.23.5(f).

**SSL** is the *system strength locational factor* applicable to the *system strength connection point*, calculated in accordance with the *system strength impact assessment guidelines*. SSL will be the same for each *regulatory year* in a *system strength charging period*.

**SSQ** is the *system strength quantity* applicable to the relevant *system strength connection point* (in MVA). It should be noted that:

- SSQ is the product of (1) the short circuit ratio and (2) the rated active power, calculated in accordance with clause 6A.23.5(j).
- If a change to SSQ comes into effect part way through a regulatory year, the monthly instalments of the *annual system strength charge* for the remaining months of the *regulatory year* will be calculated using the new *system strength quantity*, in accordance with clause 6A.23.5(k).

The *system strength charging period* commences from the start of the second regulatory year in a regulatory control period to the end of the first regulatory year in its next regulatory control period.

## 6.10.2 System Strength Unit Price

A System Strength Unit Price (**SSUP**) will be set for each *system strength node* on the transmission network. In accordance with the Rules and the AER's *pricing methodology guidelines*, the methodology determines the SSUP according to the 'forward-looking' long run average cost of providing the *system strength capacity* at each *system strength node*.

The SSUP will be calculated in real terms and index annually in accordance with this methodology. Appendix F provides worked examples to illustrate the application of the methodology, which is described below.

The SSUP is a price per MVA which reflects the forecast long run average costs of providing *System Strength Transmission Services* at the relevant *system strength node* calculated as follows:

### SSUP

=  $\frac{\text{The total long run capital and operating costs of providing an efficient quantity of system strength at a system strength node, over a period of } t \text{ years}}{\text{The total system strength hosting capacity provided by that system strength node, over a period of } t \text{ years}}$

Where:

*Long run costs* means the costs of providing *system strength capacity* at a *system strength node*, having regard to the actual and forward-looking costs of providing the required capacity at that node. Specifically:

Formatted: Font color: Auto



# Powerlink Pricing Methodology

Formatted: Font: 8 pt, Font color: Auto

- The long run costs include Powerlink’s actual costs of providing system strength capacity where the forward-looking costs are higher than Powerlink’s actual costs; and
- The long run costs include the forward-looking costs of providing system strength capacity where these costs are lower than Powerlink’s actual costs.

Capital and operating costs of providing System Strength Transmission Services means:

- The annualised capital costs of providing the required system strength capacity at a system strength node in each year for a period of t years;
- The annual operating costs required to operate and maintain network assets employed to provide the required system strength capacity at a system strength node in each year for a period of t years; and
- The annual costs of contracts with non-network service providers to provide the required system strength capacity at a system strength node in each year for a period of t years.

Total system strength hosting capacity means the quantity of system strength provided by a system strength node to supply an efficient quantity of system strength to connection points linked to that system strength node in each year for a period of t years.

Formatted: Font: Not Italic

t years is 10 years.

## Cost allocation

Formatted: Keep with next

In relation to the process of allocating capital and operating costs to system strength nodes, it should be noted that:

- The capital and operating costs of providing system strength capacity may be attributable to more than one system strength node. In such cases, the costs of providing that system strength capacity will be allocated to each of the relevant system strength nodes on a reasonable basis to reflect the percentage of that capacity used at each of those nodes.
- The capital and operating costs of providing system strength capacity at a system strength node may include an allocation from one or more sources of system strength capacity, whether that source is a network investment or a contract with a non-network service provider.
- The capital and operating costs of providing system strength capacity at a system strength node will have regard to the National Electricity Amendment (Operational Security Mechanism) Rule 2022.

## Compliance

The methodology described above is consistent with clause 2.7(a) of the AER’s pricing methodology guidelines which require that the SSUP must:

Revised Proposed Pricing Methodology Revised Proposed Amended Pricing

Methodology

4756

**ANY PRINTED COPY OF THIS DOCUMENT IS UNCONTROLLED**



## Powerlink Pricing Methodology

Formatted: Font: 8 pt, Font color: Auto

- (1) be based on a forecast of the long run average costs of providing system strength transmission services at the relevant system strength node; and
- (2) use a period of at least 10 years when forecasting long run costs.
- (3) set a price on a dollars per MVA per year basis;
- (4) set a price that is fixed for the system strength charging period; and
- (5) set a price for each system strength node.

### Indexation

In accordance with clause 2.7(b) of the AER's pricing methodology guidelines, the SSUP will be indexed annually by the same inflation series the AER uses to index the maximum allowed revenue under the revenue determination from one year to the next.

### 6.106.11 Standby service arrangements

If a customer requires a connection point to provide energy from the transmission network on a standby basis, such as to cover the outage of onsite generation, the customer will pay *prescribed exit services* charges and *prescribed TUOS services* – locational component charges as usual, but will only pay *prescribed TUOS services* – non-locational component charges and *prescribed common transmission services* charges during times that the standby service is actually utilised in energy delivery to the customer.

More specifically, prescribed transmission charges will be determined as follows:

- *Prescribed exit service* charges: as detailed in section 6.9.1;
- Prescribed TUOS locational charges: based on the prevailing *contract agreed maximum demand* and *prescribed TUOS services* – locational component price as detailed in section 6.9.2, and
- Postage stamped prescribed TUOS non-locational service charges and prescribed common transmission service charges: based on *current metered energy offtake* in the billing period as detailed in sections 6.9.3 and 6.9.4.

Where standby arrangements are required, the customer's connection agreement must specify a *contract agreed maximum demand* and excess demand charges as detailed in section [6.126.1112](#) will apply.

### 6.116.12 Excess demand charge

Where the customer's actual maximum demand exceeds the *contract agreed maximum demand* level at any time during the financial year and the customer has a *contract agreed maximum demand* in their Connection and Access Agreement (C&AA), then an excess



## Powerlink Pricing Methodology

A demand charge applies and the actual maximum demand will become the *contract agreed maximum demand*, in accordance with the customer's connection agreement.

Formatted: Font: 8 pt, Font color: Auto

Powerlink will recover from the customer the incremental charges for the increased *contract agreed maximum demand* for the whole financial year. Incremental charges collected from customers reflect what would have been paid if the *contract agreed maximum demand* had been the higher actual maximum demand.

The excess demand charge is determined in accordance with the customer's connection agreement.

### 6.126.13 Setting of TUOS locational prices between annual price publications

In the event that Powerlink is required to set a TUOS locational price at a new connection point without a previously calculated TUOS locational price, an interim price not subject to the side constraints of clause 6A.23.4(b)(2) will be determined. At an existing connection point where the load has changed significantly after prescribed TUOS service locational prices have been determined and published an interim price will be calculated subject to clause 6A.23.4(b)(3). This will be calculated using the prevailing pricing models with demands estimated in a manner consistent with clause 2.2(f) of the *pricing methodology guidelines*.

A price subject to the side constraints of clause 6A.23.4(b)(2) will be determined and published at the next annual price determination.



# Powerlink Pricing Methodology

Formatted: Font: 8 pt, Font color: Auto

## 7 BILLING ARRANGEMENTS

### 7.1 Billing for prescribed transmission services

Consistent with clause 6A.27.1, Powerlink will calculate the transmission service charges payable by *Transmission Network Users* and system strength charges payable by System Strength Transmission Service Users for each connection point in accordance with the transmission service prices published under clause 6A.24.2.

Where charges are determined for *prescribed transmission services* from metering data, these charges will be based on kW or kWh obtained from the metering data managed by AEMO.

Powerlink will issue invoices to *Transmission Network Users* for *prescribed transmission services* and to System Strength Transmission Service Users for system strength charges, which satisfy or exceed the minimum information requirements specified in clause 6A.27.2 on a monthly basis or as specified in the transmission connection agreement.

In addition to the minimum information requirements in clause 6A.27.2(a), a bill for a connection point issued directly to a Distribution Network Service Provider or Transmission Network Service Provider relating to system strength charges will separately identify the system strength charge by connection point.

Consistent with clause 6A.27.3, a *Transmission Network User* must pay charges for *prescribed transmission services* properly charged to it and billed in accordance with this *pricing methodology* by the date specified on the invoice.

### 7.2 Intra-Regional Payments between Transmission Network Service Providers

If another *TNSP* is granted a Transmission Authority and is registered as a *Transmission Network Service Provider* by AEMO in the Queensland region, one *TNSP* will become the *Co-ordinating Network Service Provider* under clause 6A.29.1. Consistent with clause 6A.27.4 the *TNSPs* will pay to each other relevant *TNSP* the revenue which is estimated to be collected during the following year by the first provider as charges for *prescribed transmission services* for the use of transmission systems owned by those other *TNSPs*. Consistent with 6A.27.5, other payments may be required as a result of revenue allocations between customers across multiple *TNSPs*.

Such payments will be determined by the *Co-ordinating Network Service Provider* for the region.

Financial transfers payable under clause 6A.27.4(b) will be paid in equal monthly instalments or as documented in revenue collection agreements negotiated between the parties.





# Powerlink Pricing Methodology

## 8 PRUDENTIAL REQUIREMENTS

Formatted: Font: 8 pt, Font color: Auto

### 8.1 Prudential requirements for prescribed transmission services

Consistent with clause 6A.28.1, Powerlink may require a *Transmission Network User* to establish prudential requirements for either or both connection services and transmission use of system services. These prudential requirements may take the form of, but need not be limited to, capital contributions, pre-payments or financial guarantees.

The requirements for such prudential requirements will be negotiated between the parties and specified in the applicable transmission connection agreement.

### 8.2 Capital contribution or prepayment for a specific asset

Powerlink notes that no capital contributions or prepayments have been made in respect of *prescribed transmission services* assets as at the date of this *pricing methodology*.

Consistent with clause 6A.28.2, where Powerlink is required to construct or acquire specific assets to provide prescribed connection services or *prescribed TUOS services* to a *Transmission Network User*, Powerlink may require that user to make a capital contribution or prepayment for all or part of the cost of the new assets installed.

In the event that a capital contribution is required, any contribution made will be taken into account in the determination of prescribed transmission service prices applicable to that user by way of a proportionate reduction in the ORC of the asset(s) used for the allocation of prescribed charges or as negotiated between the parties.

In the event that a prepayment is required, any prepayment made will be taken into account in the determination of prescribed transmission service prices applicable to that user in a manner to be negotiated between the parties.

The treatment of such capital contributions or prepayments for the purposes of a revenue determination will in all cases be in accordance with the relevant provisions of the Rules.

## 9 PRUDENT DISCOUNTS

Powerlink will address any requests for prudent discounts in accordance with the Rules.

Under clause 6A.26.1(d) to (g), Powerlink will adjust both the non-locational component of the ASRR for *prescribed TUOS services* and prescribed common transmission services (other than system strength transmission services) to provide for the amount of any anticipated under-recovery arising from a prudent discount.

The discount amount is the difference in revenue that would be recovered by the application of the maximum prices to the application of the reduced charges. Where Powerlink seeks to recover greater than 70 percent of the discount amount through these charges, Powerlink will apply to the AER for approval to recover the proposed recovery amount in accordance with clause 6A.26.2.



# Powerlink Pricing Methodology

Formatted: Font: 8 pt, Font color: Auto

Powerlink has a very small number of customers who currently receive prudent discounts calculated in accordance with 6A.26.

## 10 MONITORING AND COMPLIANCE

As a regulated business Powerlink is required to maintain extensive compliance monitoring and reporting systems to ensure compliance with its Transmission Authority, Revenue Determination and the Rules together with numerous other legislative obligations.

In order to monitor and maintain records of its compliance with its approved *pricing methodology*, the pricing principles for *prescribed transmission services*, and part J of the Rules, Powerlink proposes to:

- Maintain the specific obligations arising from part J of the Rules in its compliance management system;
- Maintain electronic records of the annual calculation of prescribed transmission service prices and supporting information; and
- Periodically subject its transmission pricing models and processes to functional audit by suitably qualified persons.

## 11 NEW CONNECTIONS REQUIRING SIGNIFICANT INVESTMENT

### 11.1 Impact on TUOS locational prices in cases of significant investment

If a new *transmission network connection point* requires significant investment in the network, Powerlink may determine the TUOS locational price for the first year in accordance with the method in section 11.2, to ensure customers who do not directly benefit from the investment are not directly or materially affected, for example, by an inequitable increase in the locational price and charges.

### 11.2 Setting TUOS locational prices in the first year of significant investment

In the event that a significant investment occurs, Powerlink may determine the locational TUOS price(s) for the new transmission network connection point(s) using cost reflective network pricing and not apply the 2% side constraint at the new connection point(s) relative to the load weighted average TUOS locational price for the region, as described in section 6.9.2.



# Powerlink Pricing Methodology

Formatted: Font: 8 pt, Font color: Auto

## 12 TRANSITIONAL ARRANGEMENTS TO IMPLEMENT THE PRICING METHODOLOGY

Powerlink has amended the methodology to calculate the locational price in section 6.9.2 to refer to the relevant percentage of the average demand component for a specific year. The average demand component of the locational price will reduce by 10 percent each year over the 2023-27 regulatory period.

Powerlink proposes to include similar transitional arrangements to reduce the average demand component in its *pricing methodology* submitted for the 2028-32 regulatory period.

In accordance with clause 2.1(j) of the *pricing methodology guidelines*, Powerlink considers that transitional arrangements are required to implement the *pricing methodology*. The following transitional arrangements apply when interpreting section 6.9.2 of the *pricing methodology*.

For each *regulatory year* over the 2023-27 regulatory period, the following percentages will apply when referenced in relation to average demand:

Regulatory Year	Percentage (%)
1 July 2022 to 30 June 2023	90
1 July 2023 to 30 June 2024	80
1 July 2024 to 30 June 2025	70
1 July 2025 to 30 June 2026	60
1 July 2026 to 30 June 2027	50

## 13 ADDITIONAL INFORMATION REQUIREMENTS

A number of additional information requirements arise from the *pricing methodology guidelines* which have not been covered elsewhere in this *pricing methodology*. In order to satisfy these requirements Powerlink notes that it does not:

- have any applicable relevant derogations in accordance with chapter 9 of the Rules; or
- have any applicable transitional arrangements arising from chapter 11 of the Rules.

Powerlink has not provided a confidential version of this *pricing methodology* to the AER in accordance with clause 2.5 of the *pricing methodology guidelines* and hence the provisions of clause 2.1(n) of the *pricing methodology guidelines* are not applicable.



# Powerlink Pricing Methodology

## 14 DESCRIPTION OF PRICING METHODOLOGY DIFFERENCES

Formatted: Font: 8 pt, Font color: Auto

This *pricing methodology* (V1.56) will apply from 1 July 2022 to 30 June 2027 and proposes amendments to the previous *pricing methodology* primarily to:

- amend address the methodology to calculate changes required by the locational price to phase out the average demand component described in section 6.9.2 subject to transitional arrangements outlined in section 12;
- include a reference to clause 6A.27.5 introduction of the Rules that outlines the mechanism for the calculation of payments between multiple *Transmission Network Service Providers* in section 7.2;
- include an adjustment to the non-locational component of *Prescribed TUOS services* to account for advised *NTP function* fees in section 6.8.3.2 System Strength Charging in accordance with clause 6A.23.3(e)(6) of the Rules;

clarify that the settlements residue adjustment to the non-locational component of *Prescribed TUOS services* described in section 6.8.3.2 will exclude amounts that accrue the AEMC's Rule determination, Efficient Management of System Strength on *designated network assets* in accordance with clause 6A.23.3(e)(2) of the Rules; the Power System Rule 2021, October 2021.

- improve clarity in the application of excess demand charges as outlined in section 6.11, to make clear that incremental charges are reflective of increased charges for the whole financial year;
- improve clarity in consistency with the AER Pricing Methodology Guidelines. In section 6.9.3, to make clear that the energy or contract agreed maximum demand price used for postage stamped charges will be the one that results in the lower estimated charge. In section 9, to identify that a very small number of prudent discounts will be in place over the 2023-27 regulatory period;
- improve clarity in the annual timeframe for publication of the MLEC to 15 February each year in Appendix D; and
- include a description of differences between pricing methodologies (V1.4 and V1.5).

### 1915 SUMMARY

Powerlink's *proposed amended pricing methodology* for the regulatory period from 1 July 2022 to 30 June 2027, effective from 1 July 2023, is submitted to the AER in accordance with Chapter 6A and clause 11.143.5 of the Rules and the AER's *pricing methodology guidelines*.

Formatted: Font color: Auto



# Powerlink Pricing Methodology

Formatted: Font: 8 pt, Font color: Auto

## Appendix A - Structure of Transmission Pricing under Part J of Rules

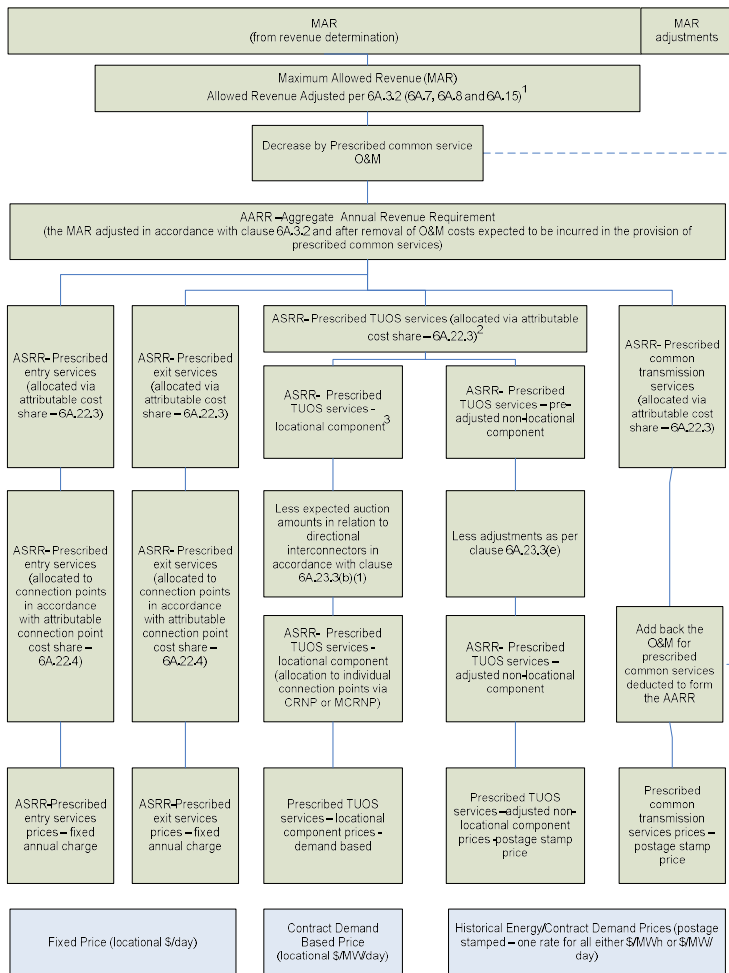

<sup>1</sup> These operating and maintenance costs are not part of the AARR, nor are they part of the ASRR for prescribed common transmission services, however they are recovered on a postage stamp basis.

<sup>2</sup> Shares of the ASRR for prescribed TUOS services are to be allocated 50% to the locational component and 50% to the pre-adjusted non-location component or using an alternative allocation as per clause 6A.23.3(a)(1).



# Powerlink Pricing Methodology

Formatted: Font: 8 pt, Font color: Auto

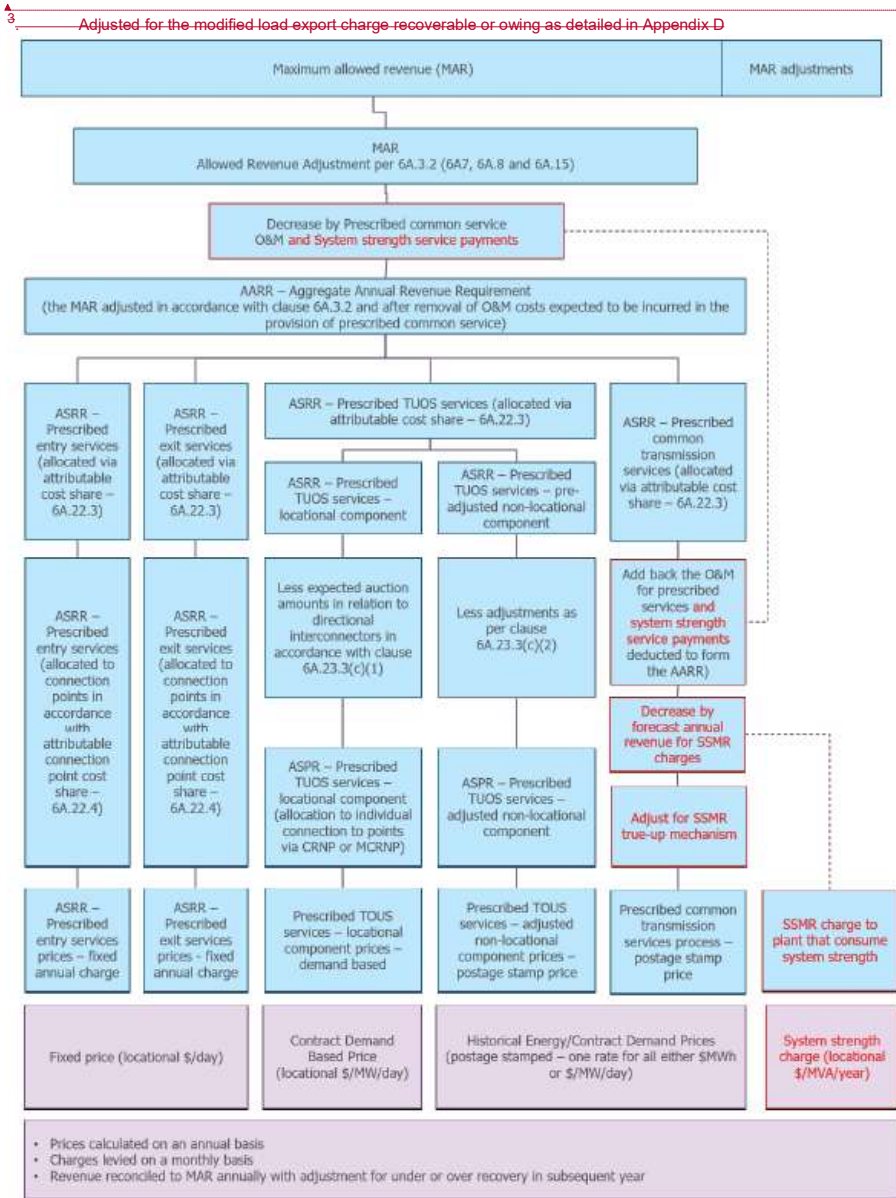



# Powerlink Pricing Methodology

Formatted: Font: 8 pt, Font color: Auto

## Appendix B - Details of Cost Allocation Process

A cost allocation process is used to assign the optimised replacement cost (ORC) of all prescribed service assets to either common service (assets that benefit all transmission customers), network branches (transmission lines or transformers)<sup>7</sup> and prescribed entry or *prescribed exit services* in a manner consistent with Section 2.4 of the *pricing methodology guidelines*.

The cost allocation process is summarised as follows:

### Step 1: Initial Cost Allocation

Assets and their ORCs are assigned to one of the following primary asset categories:

- transmission lines;
- transformers;
- circuit breakers;
- secondary systems, including protection and instrument transformers;
- common service assets (communications, reactive support, office buildings etc); and
- substation local assets (ancillary equipment, civil work, and establishment).

The following plant items are not separately identified in the ORC database and are incorporated into the ORC of the associated primary items above:

- bus work.

### Step 2: Allocation to Categories of Transmission Services

Assets are allocated to the categories of prescribed service in accordance with the provisions of Section 2.4 of the *pricing methodology guidelines*. In the case of circuit breakers each circuit breaker has its replacement cost divided evenly between the branches to which it is *directly attributable*. Any circuit breaker that is not *directly attributable* to any branch together with substation local costs identified in step 1 are subject to the priority ordering process.

In the case of a shared connection asset, such as a transformer, serving multiple transmission connection points which may provide both *prescribed entry services* and *prescribed exit services* the cost of the shared connection asset will be allocated to the appropriate category or categories of *prescribed transmission services* using an appropriate cost allocator<sup>8</sup>. For example:

<sup>7</sup> Powerlink maintains an optimised replacement cost (ORC) model of the transmission network to determine the appropriate ORC of individual transmission lines, transformers, circuit breakers, common service assets and substation local costs.

<sup>8</sup> This is consistent with Powerlink's cost allocation methodology which is used to allocate costs between *prescribed transmission services*, *negotiated transmission services* and *non-regulated transmission services*.



## Powerlink Pricing Methodology

Formatted: Font: 8 pt, Font color: Auto

- generation or reactive plant nameplate rating capacity or nominated demand supplied by the specified transmission category as a percentage of the total capacity and demand of all transmission categories at that location: Costs are attributable based on the capacity and/or nominated demand;
- unit of plant method: Costs are allocated based on the number of units of plant installed (typically circuit breakers) where these units of plant can be attributed to a particular category of transmission service; or
- as negotiated between the connecting parties.

This process would also be adopted to allocate shared costs to individual connection points.

### Step 3: Priority Ordering

In the case of those costs which would be attributable to more than one category of *prescribed transmission services*, specifically the substation local assets identified in Step 1 and those circuit breakers identified as substation local costs in Step 2, costs will be allocated in accordance with the provisions of clause 6A.23.2(d) having regard to the stand alone costs associated with the provision of *prescribed TUOS services* and *prescribed common transmission services* with the remainder being allocated to *prescribed entry services* and *prescribed exit services*. The implementation of the priority ordering process is detailed in Appendix E.

### Conclusion

The shared network costs resulting from the cost allocation process are used as input to TPRICE, the *Cost Reflective Network Pricing* software that is approved by the AER for use by TNSPs in the NEM.

The entry, exit and common service costs are used as input to the calculation of *prescribed entry services* prices, *prescribed exit services* prices and *prescribed common transmission services* prices.





# Powerlink Pricing Methodology

Formatted: Font: 8 pt, Font color: Auto

## Appendix C - Cost Reflective Network Pricing Methodology

### Steps

The *cost reflective network pricing methodology (CRNP methodology)* involves the following steps:

- (1) determining the annual costs of the individual transmission network assets in the optimised transmission network;
- (2) determining the proportion of each individual network element utilised in providing a transmission service to each point in the network for specified operating conditions;
- (3) determining the maximum flow imposed on each transmission element by load at each connection point;
- (4) allocating the costs attributed to the individual transmission elements to loads based on the proportionate use of the elements; and
- (5) determining the total cost (lump sum) allocated to each point by adding the share of the costs of each individual network element attributed to each point in the network.

### Allocation of Generation to Load

A major assumption in the use of the *CRNP methodology* is the definition of the generation source and the point where load is taken. The approach is to use the "electrical distance" to pair generation to load, in which a greater proportion of load at a particular location is supplied by generators that are electrically closer than those that are electrically remote. In electrical engineering terminology the "electrical distance" is the impedance between the two locations, and this can readily be determined through a standard engineering calculation called the "fault level calculation".

Once the assumption has been made as to the generators that are supplying each load for a particular load and generation condition (time of day) it is possible to trace the flow through the network that results from supplying each load (or generator). The use made of any element by a particular load is then simply the ratio of the flow on the element resulting from the supply to this load to the total use of the load made by all loads and generators in the system.

### Operating Conditions for Cost Allocation

The choice of operating conditions is important in developing prices using the *CRNP methodology*. Powerlink has flexibility in the choice of operating conditions but notes that the old NER set out the principles that should apply in determining the sample of operating conditions considered. Of particular note is the requirement that the operating conditions to be used are to include at least 10 days with high system demand, to ensure that loading conditions, which impose peak flows on all transmission elements, are captured.



## Powerlink Pricing Methodology

Schedule 6A.3.2(3) is less prescriptive requiring that the allocation of dispatched generation to loads be over a range of actual operating conditions from the previous financial year and that the range of operating scenarios is chosen so as to include the conditions that result in most stress on the transmission network and for which network investment may be contemplated.

Formatted: Font: 8 pt, Font color: Auto

### Load and generation data

Clause 2.2(a) of the *pricing methodology guidelines* requires that prices for the recovery of the locational component of *prescribed TUOS services* are based on demand at times of greatest utilisation of the transmission network and for which network investment is most likely to be contemplated, in accordance with clause 6A.23.4(b)(1).

The use made of the network by particular loads and generators will vary considerably depending on the load and generation conditions on the network. For this reason Powerlink uses the full year of operating data (i.e. 365 days of half hourly data) as an appropriate set of operating conditions. The TPRICE capacity method of cost allocation (used by Powerlink) automatically captures the peak loading conditions on network elements from the sample of operating conditions analysed.

Consistent with clause 2.2(f) of the *pricing methodology guidelines* where actual operating conditions from the previous complete financial year are unavailable for a connection point, as would be the case for a new connection point, an estimate based on the *contract agreed maximum demand* and other characteristics of the load would be used to allocate costs to that connection point.



# Powerlink Pricing Methodology

## Appendix D - Modified Load Export Charge Cost Reflective Network Pricing Methodology

Formatted: Font: 8 pt, Font color: Auto

### Introduction

The inter-regional transmission charging arrangements allow transmission businesses to levy a modified load export charge on transmission businesses in neighbouring regions. Transmission load customers would subsequently pay a share of the costs of transmission used to import electricity into their region from neighbouring regions.

As the *Co-ordinating Network Service Provider* referred to in clause 6A.29.1 of the Rules, Powerlink will calculate the AARR for the Queensland region, and will calculate, bill and arrange for the payment of the modified load export charge (MLEC) in accordance with 6A.29A of the Rules and the Section 2.6 of the AER's *amended pricing methodology guidelines*.

Powerlink will publish details of all modified load export charges to apply in the following financial year on its website by 15 February<sup>9</sup> each year consistent with clause 6A.24.2(b) of the Rules.

### Overview of the process

An overview of the process to calculate MLEC is shown in the diagram below.

<sup>9</sup> The AEMC's Distribution Network Pricing Arrangements Rule (27 November 2014) requires a timing of 15 February from 2017 onwards.



# Powerlink Pricing Methodology

Formatted: Font: 8 pt, Font color: Auto

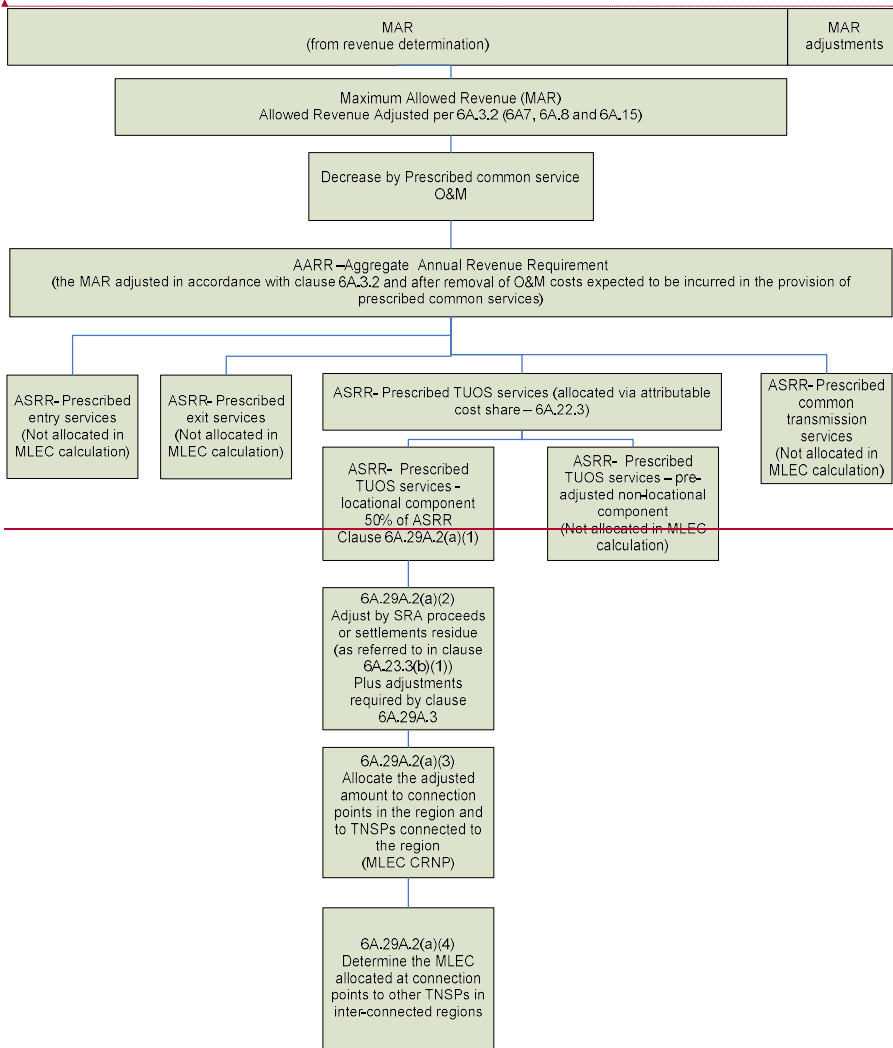



# Powerlink Pricing Methodology

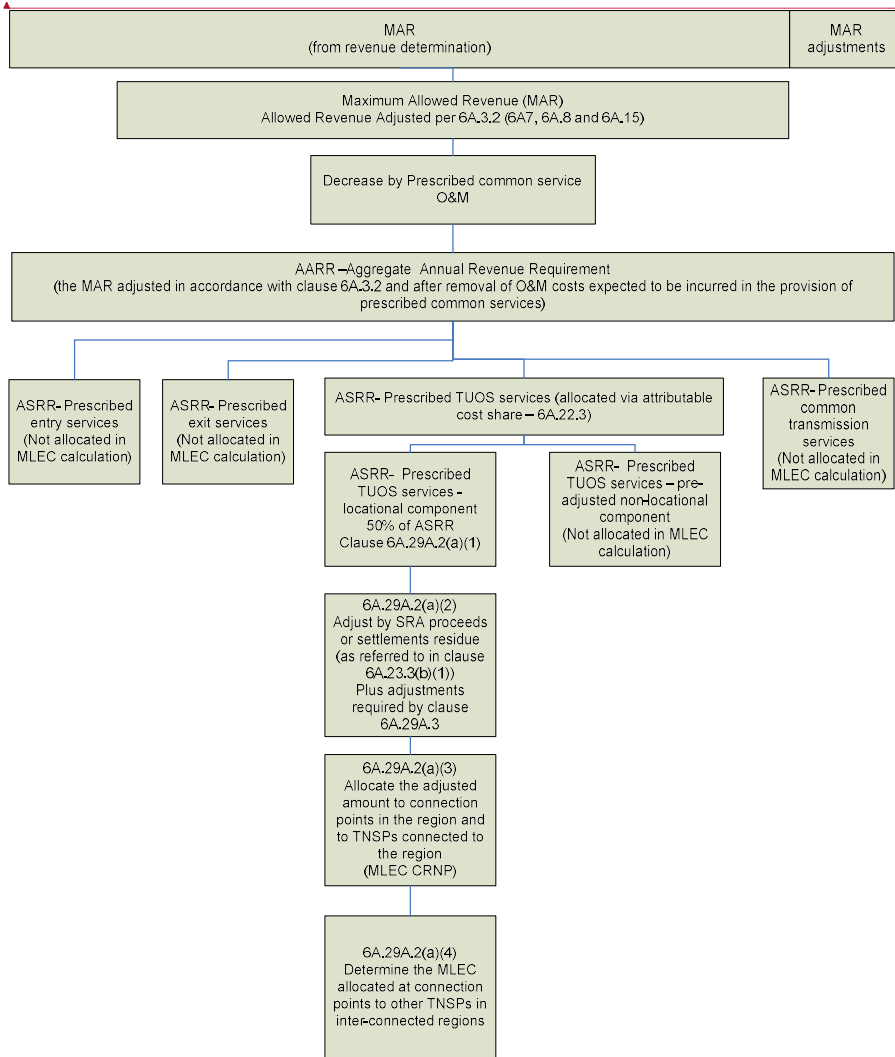

Formatted: Font: 8 pt, Font color: Auto  
Field Code Changed



## Powerlink Pricing Methodology

Formatted: Font: 8 pt, Font color: Auto

The steps involved to calculate MLEC are:

### Step 1

The AARR will be calculated as described in section 5 of Powerlink's *pricing methodology*.

The allocation of the AARR to each of the transmission service categories will be calculated as described in Section 6 of Powerlink's *pricing methodology*. This will determine the ASRR to be recovered from prescribed TUOS services. The calculations in Step 1 are the same as for calculating transmission prices.

### Step 2

As required by clause 6A.29A.2(a)(1) of the Rules, the modified load export charge is to be calculated as 50% of the ASRR for prescribed TUOS services.

### Step 3

The amount determined in Step 2 is the TUOS revenue to be recovered on a locational basis and is adjusted in accordance with clause 6A.29A.2(a)(2) of the Rules by:

- subtracting estimated inter-regional settlements residue auction proceeds;
- subtracting a portion of the settlements residue as referred to in clause 6A.23.3(b)(1);
- including any adjustments as required by 6A.29A.3.

### Step 4

Clause 6A.29A.2(a)(3) requires the adjusted amount from Step 3 to be allocated to connection points of transmission customers in the Queensland region and to CNSPs interconnected to the Queensland region as if they were connected as transmission customers. This allocation will be made on a proportionate use of transmission system assets. Consistent with the requirements of clause 6A.29A.2(a)(3), Powerlink will only use the MLEC CRNP methodology for estimating the proportionate use of the relevant transmission system assets.

Powerlink applies the CRNP methodology using the T-PRICE cost reflective network pricing software used by all TNSPs in the NEM.

The CRNP methodology requires three sets of input data:

- an electrical (load flow) model of the network;
- a cost model of the network; and
- a set of load/generation patterns.

Appendix C of Powerlink's Pricing Methodology describes the CRNP methodology in more detail.



# Powerlink Pricing Methodology

Formatted: Font: 8 pt, Font color: Auto

The key requirements for MLEC CRNP are:

- The modified load export charge to be determined using standard CRNP approach.
- All transmission elements are to be included.
- All half hour periods in the previous full financial year are to be used.
- Peak usage of assets must be used.

For each regulatory year Powerlink will calculate the modified load export charge using the MLEC CRNP approach. The calculation will use generation and load data from the previous financial year completed at the time the MLEC CRNP is being calculated.

### Step 5

Clause 6A.29A.2(a)(4) requires the modified load export charge to be recovered from Co-ordinating Network Service Providers in interconnected regions to be the amount allocated to connection points to neighbouring regions as determined in Step 4.

### Timetable for the provision of data

In the event that *prescribed transmission services* within Queensland are provided by more than one TNSP, as required by 6A.29A.4(e), each TNSP located in the region is required to provide the CNSP with all information reasonably required for the calculation of the MLEC estimate.

To facilitate this information transfer, Section 2.6(e) of the AER's *pricing methodology guidelines* require a CNSP to specify a timetable for the provision of all necessary data for the calculation of the inter-regional and intra-regional transmission charges.

The following timetable for the provision of data will facilitate the calculation of all Modified load export charges to apply in the region by 15 February<sup>10</sup> each year.

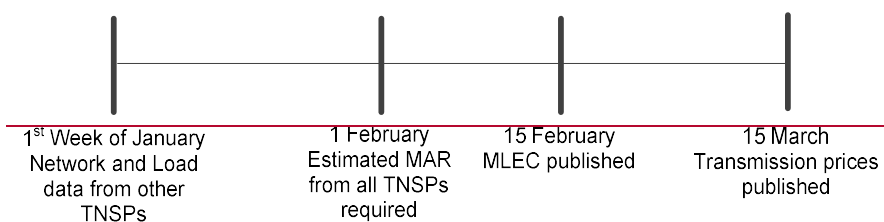

<sup>10</sup> The AEMC's Distribution Network Pricing Arrangements Rule (27 November 2014) requires a timing of 15 February from 2017 onwards.



# Powerlink Pricing Methodology

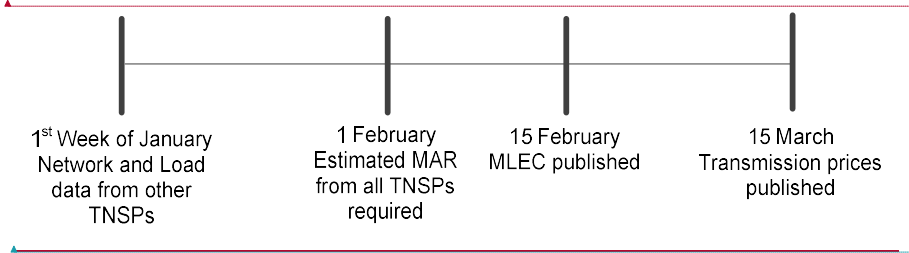

Formatted: Font: 8 pt, Font color: Auto  
Field Code Changed





## Powerlink Pricing Methodology

### Billing the modified load export charge

Formatted: Font: 8 pt, Font color: Auto

Powerlink will issue a monthly bill to the CNSP in each interconnected region for the MLEC amount payable to Powerlink in accordance with clause 6A.29A.4(a) of the Rules. The monthly bills will include any adjustments made to it in accordance with the Rules (clause 6A.29A.3).

In accordance with clause 6A.29A.4(b) of the Rules, the monthly bill will include:

- the total annual estimate of MLEC payable by the CNSP;
- details of the MLEC CRNP allocation and the adjustments as specified in clauses 6A.29A.3 and 6A.23.3(f); and
- the monthly instalment amount.

### Worked example – modified load export charge

The worked example uses the same amounts referred to in the examples of the *pricing methodology*.

#### Step 1 – Aggregate annual revenue requirement (AARR)

In accordance with clause 6A.22.1, the maximum allowed revenue is adjusted:

- 1) in accordance with clause 6A.3.2; and
- 2) by subtracting the operating and maintenance costs expected to be incurred in the provision of prescribed common transmission services and expected system strength service payments; and
- 3) by any allocation as agreed between Transmission Network Service Providers in accordance with clause 6A.29.3.

This example assumes that the maximum allowed revenue is \$2,604,434.



## Powerlink Pricing Methodology

Table D.1

### Derivation of AARR to be allocated to the four services

Derivation	Amount (\$)
Maximum allowed revenue	2,604,434
Total adjustments for:	
• network support pass through;	
• cost pass through;	-45,000
• payments or penalties under the service target performance incentive scheme; and	
• contingent projects.	
Deduct operating and maintenance expenditure (incurred in the provision of prescribed common services) <u>and</u> <u>expected system strength service payments</u>	-55,000
<b>AARR to be allocated</b>	<b>2,504,434</b>

Formatted: Font: 8 pt, Font color: Auto

### Step 2 – Annual service revenue requirement

Similar to the calculation example in section 6.2 of the *pricing methodology*, the ASRR for each category of service is calculated as shown in Table D.2.

Table D.2

### Asset allocations to service categories

Category	Asset Value (\$)	Cost Share
Exit service	6,972,222	16.2%
Entry service	1,761,111	4.1%
TUOS service	33,566,667	78.0%
Common service	750,000	1.7%
<b>Total</b>	<b>43,050,000</b>	<b>100.0%</b>

The cost share percentages shown in Table D.2 are used to allocate the revenue to be recovered from each service category. In accordance with the adjustments set out in Table D.1, Table D.3 shows that the revenue to be allocated (the AARR) is \$2,504,434.



## Powerlink Pricing Methodology

**Table D.3****Calculation of Annual Service Revenue Requirements (ASRR)**

Category	Cost Share	Revenue (AARR) to be recovered from each service (\$)
Exit service	16.2%	405,609
Entry service	4.1%	102,453
TUOS service	78.0%	1,952,741
Common service	1.7%	43,631
<b>Total</b>	<b>100.0%</b>	<b>2,504,434</b>

Formatted: Font: 8 pt, Font color: Auto

Clause 6A.29A.2(a)(1) then requires 50% of the ASRR for prescribed TUOS services to be calculated.

**Table D.4****Calculation of pre-adjusted locational component**

Category	Asset Value (\$)
50% of TUOS service	976,371

### Step 3 – Adjustment for settlement residue auction proceeds

For this example the SRA proceeds and other adjustments are assumed to be zero.

### Step 4 – Standard CRNP Calculation

An electrical model of the Queensland transmission network is set up including all transmission elements. The TPRICE software is used to calculate the allocation of costs based on a proportionate use of transmission system assets. The total allocation to each connection point to another region is then determined.

**Table D.5****Standard CRNP allocation and I/C cost share**

Connection Point	CRNP ORC Allocation (\$k)	Cost Share
QNI	400	1%
<b>Total for I/C connection points</b>	<b>400</b>	<b>1%</b>
<b>Total for all connection points</b>	<b>33,566,667</b>	



## Powerlink Pricing Methodology

### Step 5 – Modified load export charge to be recovered

The revenue to be recovered is pro-rated using the adjusted AARR from Step 2.

**Table D.6**

#### Modified load export charge

Connection Point	Cost Share	Revenue to be recovered from each connection point (\$)
QNI	1%	11,635
<b>Modified load export charge for the New South Wales region</b>		<b>11,635</b>

In the event that *prescribed transmission services* within Queensland are provided by more than one TNSP the calculated MLEC amount from Step 5 will be allocated and billed to each TNSP within Queensland in accordance with clause 6A.29A.5.

**Table D.7**

#### Modified load export charge attributed to each TNSP in Queensland region

Connection Point	Cost Share of MLEC	MLEC for each TNSP (\$)
TNSP 1 – Connection Point 1	40%	4,654
TNSP 1 – Connection Point 2	20%	2,327
TNSP 1 – Connection Point 3	10%	1,164
<b>MLEC for Region 1</b>		<b>8,145</b>
TNSP 2 – Connection Point 1	20%	2,327
TNSP 2 – Connection Point 2	10%	1,164
<b>MLEC for Region 2</b>		<b>3,491</b>
<b>Total for all connection points</b>		<b>11,635</b>

Formatted: Font: 8 pt, Font color: Auto

Formatted: Font: (Default) Arial

Formatted: Space After: 5 pt

Formatted: Font: (Default) Arial

Formatted: Space After: 5 pt



# Powerlink Pricing Methodology

Formatted: Font: 8 pt, Font color: Auto

## Appendix E - Priority Ordering Methodology

### Rules Requirements

Clause 6A.23.2 (d) requires that:

Where, as a result of the application of the *attributable cost share*, a portion of the *AARR* would be attributable to more than one category of *prescribed transmission services*, that *attributable cost share* is to be adjusted and applied such that any costs of a *transmission system asset* that would otherwise be attributed to the provision of more than one category of *prescribed transmission services*, is allocated as follows:

- (1) to the provision of *prescribed TUOS services*, but only to the extent of the *stand-alone amount* for that *category of prescribed transmission services*;
- (2) if any portion of the costs of a *transmission system asset* is not allocated to *prescribed TUOS services*, under subparagraph (1), that portion is to be allocated to *prescribed common transmission services*, but only to the extent of the *stand-alone amount* for that *category of prescribed transmission services*; and
- (3) if any portion of the costs of a *transmission system asset* is not attributed to *prescribed transmission services* under subparagraphs (1) and (2), that portion is to be attributed to *prescribed entry services* and *prescribed exit services*.

Stand-alone amount is defined as:

For a *category of prescribed transmission services*, the costs of a *transmission system asset* that would have been incurred had that *transmission system asset* been developed, exclusively to provide that *category of prescribed transmission services*.

Transitional Rule 11.6.11(c) states the following:

"For the purposes of new Chapter 6A:

- (1) the costs of the *transmission system assets* that from time to time may be treated as:
  - (i) directly attributable to the provision of a prescribed connection service; or
  - (ii) incurred in providing a prescribed connection service,  
  
to a *Transmission Network User* or a group of *Transmission Network Users* at a *transmission network connection point* is limited to the costs of the eligible assets which, from time to time, provide that prescribed connection service;
- (2) any costs of an existing asset or a replacement asset (or of any portion of an existing asset or a replacement asset) that:
  - (i) is not an eligible asset (other than as a result of clause 11.6.11(d)); and



## Powerlink Pricing Methodology

(ii) is used by a *Transmission Network Service Provider* to provide *connection services* to a *Transmission Network User* or a group of *Transmission Network Users* at a *transmission network connection point*,

must be treated as costs that are directly attributable to the provision of, or are incurred in providing, *prescribed TUOS services* and, to avoid doubt, the services provided by those assets which would otherwise be *connection services* are taken to be *prescribed TUOS services*; and

(3) the *stand-alone amount* for *prescribed TUOS services* is taken to include any portion of the costs referred to in clause 11.6.11(c)(2) that has not been allocated under clause 6A.23.2(d)(1)."

### Objective and General Approach

The allocation methodology relies on the assumption that substation infrastructure and establishment costs are proportionate to the number of high voltage circuit breakers in the substation.

Based on this assumption the appropriate allocator for substation infrastructure and establishment costs for a stand-alone arrangement is the ratio of the number of high voltage circuit breakers<sup>11</sup> in the stand-alone arrangement to the number of high voltage circuit breakers in the whole substation.

### Methodology

#### **Step 1: Branch Identification**

Identify the branches<sup>12</sup>, being the lines, transformers, major reactive devices and exits/entries in the substation which provide prescribed TUOS, *prescribed common transmission services* and exit or entry services, in the substation.

#### **Step 2: Allocation of Circuit Breakers to Branches**

For each high voltage circuit breaker in the substation identify the branches directly connected to it. Any circuit breaker that does not directly connect to a branch is excluded from allocation and all costs associated with it are added to the substation infrastructure and establishment cost.

Count the total number of circuit breakers directly connected to branches.

Distribution Network Service Providers (DNSPs) are classified as a prescribed exit service while Generators are classified as a prescribed entry service. Negotiated services are not part of the regulated asset base and fall outside the priority ordering process detailed in clause 6A.23.2(d).

<sup>11</sup> Low voltage circuit breakers are not considered in the standalone arrangements.

<sup>12</sup> Described in [Definition - Branches](#)~~Definition - Branches~~.

Formatted: Font: 8 pt, Font color: Auto

Formatted: Font: 9 pt, Not Bold



## Powerlink Pricing Methodology

Formatted: Font: 8 pt, Font color: Auto

### Step 3.1: Stand-alone arrangements for Prescribed TUOS

With reference to the number of lines providing *prescribed TUOS services* determine the number of circuit breakers required to provide TUOS services of an equivalent standard on a stand-alone basis<sup>13</sup>. The stand-alone configuration is the simplest substation configuration (in the absence of development) had it been developed to provide a prescribed TUOS service. This may be done by way of a look up of typical stand-alone configurations.

### Step 3.2: Stand-alone arrangements for Prescribed common transmission services

With reference to the number of lines providing *prescribed TUOS services* and the devices providing *prescribed common service* determine the number of circuit breakers required to provide *prescribed common transmission services* of an equivalent standard on a stand-alone basis. The stand-alone configuration is the simplest substation configuration (in the absence of development) had it been developed to provide a *prescribed common service*. This may be done by way of a look up of typical stand-alone configurations.

### Step 4: Allocation of substation infrastructure and establishment costs

#### Step 4.1 Allocation of Prescribed TUOS

Allocate a portion of substation infrastructure and establishment costs to prescribed TUOS according to the ratio of the high voltage circuit breakers identified in step 3.1 to the total number of high voltage circuit breakers connected to branches in the substation identified in step 2.

#### Step 4.2 Calculation of the Unallocated Substation Infrastructure Costs (after TUOS Allocation)

Calculate the unallocated substation infrastructure cost (after TUOS allocation) by subtracting the amount calculated in step 4.1 from the total substation infrastructure amount.

#### Step 4.3 Allocation of Prescribed Common Service

Allocate a portion of the substation infrastructure and establishment costs to prescribed common service based on to the ratio of the high voltage circuit breakers providing prescribed common transmission services identified in step 3.2 to the total number of high voltage circuit breakers connected to branches in the substation. If the common service portion of substation infrastructure is greater than the unallocated costs, then the unallocated portion only is attributed to prescribed common service. In this instance, nothing will be attributed to prescribed entry and *prescribed exit services*.

<sup>13</sup> A substation would typically not exist to provide TUOS services alone, however this interpretation is inconsistent with the intent of the Rule. Accordingly standalone arrangements for prescribed TUOS are taken to require a level of switching consistent with the prevailing bus arrangements.

## Powerlink Pricing Methodology

### Step 4.4 Calculation of the Unallocated Substation Infrastructure Costs (after Common Service Allocation)

Calculate the unallocated substation infrastructure cost (after Common Service allocation) by subtracting the amount calculated in step 4.3 from the amount calculated in step 4.2.

### Step 4.5 Allocation of Prescribed Entry and Exit Service costs or to Prescribed TUOS as per clause 11.6.11

Allocate the remaining substation infrastructure and establishment costs (calculated in step 4.4) to each branch providing *prescribed TUOS services* based on the ratio of the high voltage circuit breakers providing the *prescribed TUOS services* to the branch to the total number of high voltage circuit breakers providing *prescribed TUOS services* or in accordance with the cost allocation process in Appendix B as appropriate.

#### Notes

- Costs are only allocated in step 4 until fully allocated.
- Consistent with clause 6A.23.2(d)(3) it is possible that no costs will be attributed to entry and exit services.
- New and existing negotiated service assets are excluded from the analysis as any incremental establishment costs associated with them are taken to be included in the negotiated services charges on a causation basis.
- The assessment of standalone arrangements only needs to be conducted once per substation except where changes to the configuration of the substation occur.

#### Definition - Branches

As illustrated by the diagrams below a "Branch" is a collection of assets (e.g. lines, circuit breakers, capacitors, buses and transformers) that provide a transmission service.

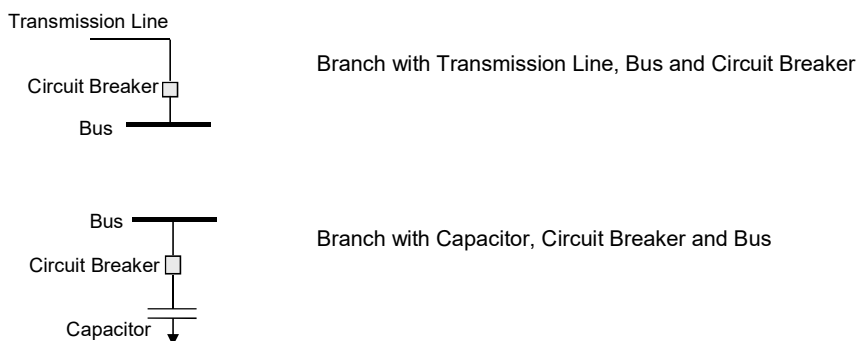

Formatted: Font: 8 pt, Font color: Auto



# Powerlink Pricing Methodology

Formatted: Font: 8 pt, Font color: Auto

Examples

Example A

Substation Configuration

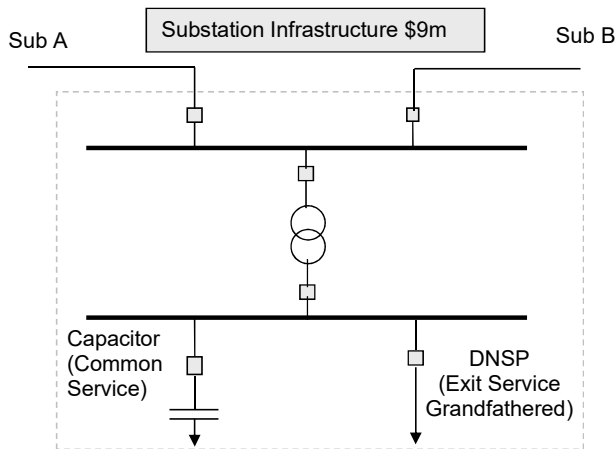

Step 1: The branches are Sub A, Sub B, DNSP, Tie Transformer and *Prescribed Common Service*.

Step 2: The total number of circuit breakers directly connected to branches is 6.

Step 3.1: The stand-alone arrangement for the provision of *prescribed TUOS services* to an equivalent standard is shown below and consists of 2 circuit breakers.

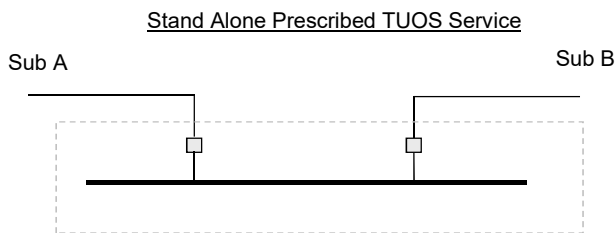

# Powerlink Pricing Methodology

Formatted: Font: 8 pt, Font color: Auto

Step 3.2: The stand-alone arrangement for the provision of *prescribed common transmission services* to an equivalent standard is shown below and consists of 3 circuit breakers.

Stand Alone Prescribed Common Service

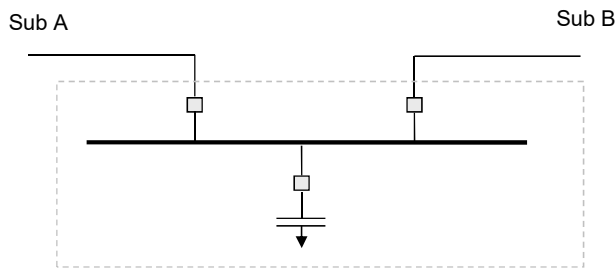

Step 4:

Assume total Infrastructure cost is \$9m.

Costs are allocated to prescribed TUOS in the ratio of the circuit breakers in the stand-alone arrangement to the total circuit breakers.

Infrastructure Cost Allocated to TUOS =  $(2/6) \times \$9m = \$3m$

Unallocated Substation Infrastructure Costs (after TUOS allocation) =  $\$9m - \$3m = \$6m$

Costs are allocated to *prescribed common service* in the ratio of the circuit breakers in the stand-alone arrangement to the total circuit breakers.

Infrastructure Cost allocated to Common Service =  $(3/6) \times \$9m = \$4.5m$

Unallocated Substation Infrastructure Costs (after Common Service allocation)  
=  $\$6m - \$4.5m = \$1.5m$

Remainder of unallocated (calculated above) to be allocated to *prescribed TUOS per 11.6.11*

Infrastructure Cost allocated to prescribed TUOS = \$1.5m

Item	Number	Allocation	Unallocated
Substation infrastructure costs		9,000,000	9,000,000
Total Breakers	6		
TUOS Stand-alone breakers	2		
Share to TUOS (a)	0.333	3,000,000	6,000,000
Common Service stand-alone breakers	3		
Share to Common Service	0.500	4,500,000	1,500,000
Share to TUOS (b)		1,500,000	
Total Share to TUOS (a) + (b)		4,500,000	
Total Share to Common Service		4,500,000	

# Powerlink Pricing Methodology

**Example B**

Formatted: Font: 8 pt, Font color: Auto

**Substation Configuration**

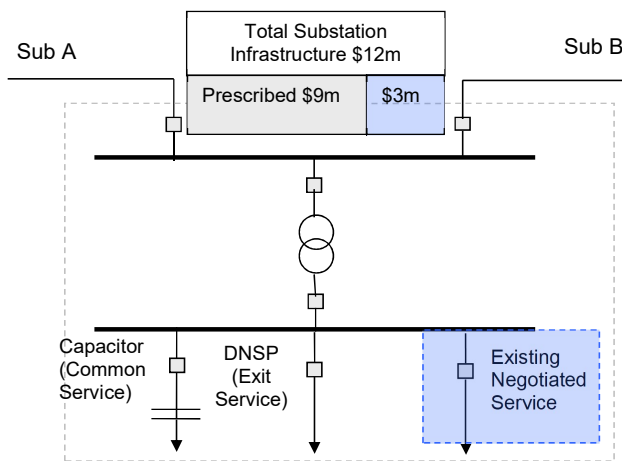

Step 1: The branches are Sub A, Sub B, DNSP, Tie Transformer, *Prescribed Common Service* and an existing negotiated service.

Step 2: The total number of circuit breakers directly connected to branches is 6 (no prescribed costs are allocated to the existing negotiated service).

Step 3.1: The stand-alone arrangement for the provision of *prescribed TUOS services* to an equivalent standard is shown below and consists of 2 circuit breakers.

Stand Alone Prescribed TUOS Service



# Powerlink Pricing Methodology

Formatted: Font: 8 pt, Font color: Auto

Step 3.2: The stand-alone arrangement for the provision of *prescribed common transmission services* to an equivalent standard is shown below and consists of 3 circuit breakers.

Stand Alone Prescribed Common Service

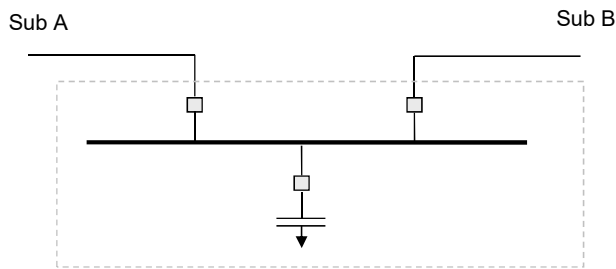

Step 4:

Assume total Infrastructure cost is \$12m, however \$3m is for the existing negotiated service, which does not form part of the regulated asset base and is not governed by 6A.23.2(d).

Costs are allocated to prescribed TUOS in the ratio of the circuit breakers in the stand-alone arrangement to the total circuit breakers.

$$\text{Infrastructure Cost Allocated to TUOS} = (2/6) \times \$9\text{m} = \$3\text{m}$$

$$\text{Unallocated Substation Infrastructure Costs (after TUOS allocation)} = \$9\text{m} - \$3\text{m} = \$6\text{m}$$

Costs are allocated to *prescribed common service* in the ratio of the circuit breakers in the stand-alone arrangement to the total circuit breakers.

$$\text{Infrastructure Cost allocated to Common Service} = (3/6) \times \$9\text{m} = \$4.5\text{m}$$

$$\begin{aligned} \text{Unallocated Substation Infrastructure Costs (after Common Service allocation)} \\ = \$6\text{m} - \$4.5\text{m} = \$1.5\text{m} \end{aligned}$$

Remainder of unallocated (calculated above) to be allocated to *prescribed exit service*.

$$\text{Infrastructure Cost allocated to Exit Service} = \$1.5\text{m}$$

Item	Number	Allocation	Unallocated
Substation infrastructure costs		9,000,000	9,000,000
Total Breakers	6		
TUOS Stand-alone breakers	2		
Share to TUOS	0.333	3,000,000	6,000,000
Common Service stand-alone breakers	3		
Share to Common Service	0.500	4,500,000	1,500,000
Share to Exit Service		1,500,000	

# Powerlink Pricing Methodology

Example C

**Substation Configuration**

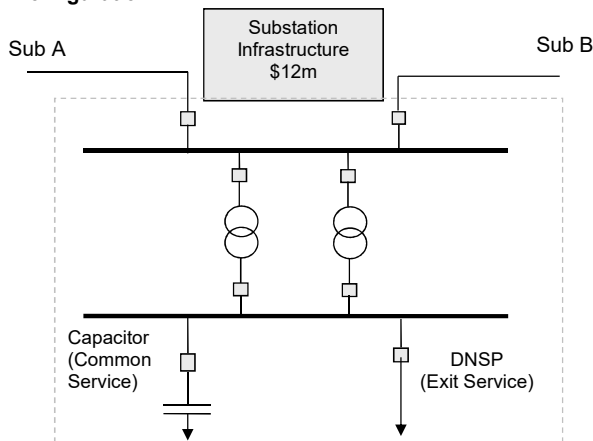

Step 1: The branches are Sub A, Sub B, DNSP, Tie Transformer 1, Tie Transformer 2 and *Prescribed Common Service*.

Step 2: The total number of circuit breakers directly connected to branches is 8.

Step 3.1: The stand-alone arrangement for the provision of *prescribed TUOS services* to an equivalent standard is shown below and consists of 2 circuit breakers.

Stand Alone Prescribed TUOS



# Powerlink Pricing Methodology

Step 3.2: The stand-alone arrangement for the provision of *prescribed common transmission services* to an equivalent standard is shown below and consists of 3 circuit breakers.

Stand Alone Prescribed Common Service

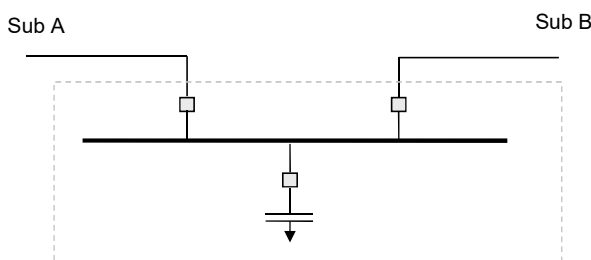

Step 4:

Assume total Infrastructure cost is \$12m.

Costs are allocated to prescribed TUOS in the ratio of the circuit breakers in the stand-alone arrangement to the total circuit breakers.

$$\text{Infrastructure Cost Allocated to TUOS (a)} = (2/8) \times \$12\text{m} = \$3\text{m}$$

$$\text{Unallocated Substation Infrastructure Costs (after TUOS allocation)} = \$12\text{m} - \$3\text{m} = \$9\text{m}$$

Costs are allocated to *prescribed common service* in the ratio of the circuit breakers in the stand-alone arrangement to the total circuit breakers.

$$\text{Infrastructure Cost allocated to Common Service} = (3/8) \times \$12\text{m} = \$4.5\text{m}$$

$$\begin{aligned} \text{Unallocated Substation Infrastructure Costs (after Common Service allocation)} \\ = \$9\text{m} - \$4.5\text{m} = \$4.5\text{m} \end{aligned}$$

Remainder of unallocated (calculated above) to be allocated to *prescribed exit service*.

$$\text{Infrastructure Cost allocated to Exit Service} = \$4.5\text{m}$$

Item	Number	Allocation	Unallocated
Substation infrastructure costs		12,000,000	12,000,000
Total Breakers	8		
TUOS Stand-alone breakers	2		
Share to TUOS	0.250	3,000,000	9,000,000
Common Service stand-alone breakers	3		
Share to Common Service	0.375	4,500,000	4,500,000
Share to Exit service		4,500,000	

# Powerlink Pricing Methodology

Example D

**Substation Configuration**

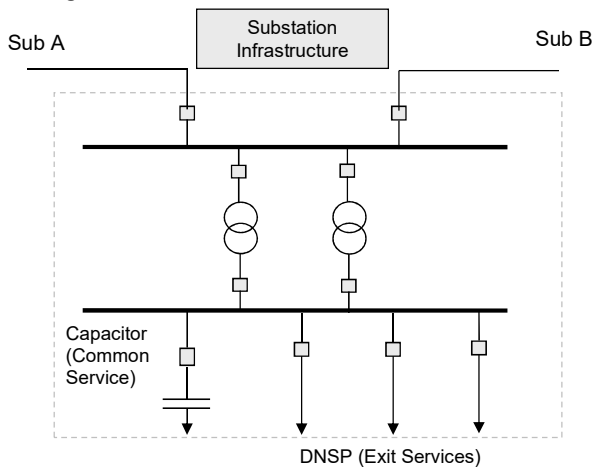

Step 1: The branches are Sub A, Sub B, DNSP1, DNSP2, DNSP3, Tie Transformer 1, Tie Transformer 2 and PCS.

Step 2: The total number of circuit breakers directly connected to branches is 10.

Step 3.1: The stand-alone arrangement for the provision of *prescribed TUOS services* to an equivalent standard is shown below and consists of 2 circuit breakers.

Stand Alone Prescribed TUOS





# Powerlink Pricing Methodology

Step 3.2:

The stand-alone arrangement for the provision of *prescribed common transmission services* to an equivalent standard is shown below and consists of 3 circuit breakers.

Stand Alone Prescribed Common Service

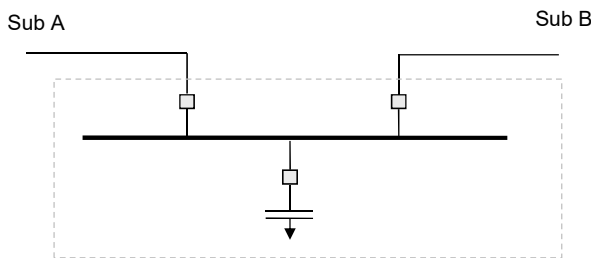

Step 4:

Assume total Infrastructure cost is \$15m.

Costs are allocated to prescribed TUOS in the ratio of the circuit breakers in the stand-alone arrangement to the total circuit breakers.

$$\text{Infrastructure Cost Allocated to TUOS} = (2/10) \times \$15\text{m} = \$3\text{m}$$

$$\text{Unallocated} = \$15\text{m} - \$3\text{m} = \$12\text{m}$$

Costs are allocated to *prescribed common service* in the ratio of the circuit breakers in the stand-alone arrangement to the total circuit breakers.

$$\text{Infrastructure Cost allocated to Common Service} = (3/10) \times \$15\text{m} = \$4.5\text{m}$$

$$\text{Unallocated} = \$12\text{m} - \$4.5\text{m} = \$7.5\text{m}$$

Remainder of unallocated (calculated above) to be allocated to *prescribed exit service*.

$$\text{Infrastructure Cost allocated to Exit Service} = \$7.5\text{m}$$

Item	Number	Allocation	Unallocated
Substation infrastructure costs		15,000,000	15,000,000
Total Breakers	10		
TUOS Stand-alone breakers	2		
Share to TUOS	0.200	3,000,000	12,000,000
Common Service stand-alone breakers	3		
Share to Common Service	0.300	4,500,000	7,500,000
Exit Service		7,500,000	





# Powerlink Pricing Methodology



# Powerlink Pricing Methodology

Formatted Table

## Appendix F – System Strength Charges

Formatted: Font: 14 pt

Formatted: Appendix

Formatted: Font: 14 pt

Formatted: Font: 14 pt, Not Bold

The AER's explanatory statement explained that:<sup>14</sup>

- A system strength provider's proposed methodology for setting the System Strength Unit Price (SSUP) must be based on the long run average cost (LRAC) of providing system strength services at each system strength node;
- System strength providers must use a period of at least 10 years when forecasting long run costs; and
- If the unit price is updated for indexation each year, the basis for indexation must be consistent with the approach for inflation indexation of the transmission network's maximum allowed revenue under its revenue determination.

As explained in this pricing methodology, our proposed approach to setting System Strength Charges complies with these requirements.

The purpose of this Appendix F is to provide illustrative numerical examples to show how the pricing methodology may apply in the following cases:

- Case 1: LRAC set for 10 year period, using a combination of network and non-network solutions; and
- Case 2: As per Case 1, with SSUP reset for years 6-15 with existing network solutions no longer reflecting the forward-looking costs.

In both cases, the SSUP calculates the LRAC over a 10 year period. The examples illustrate how the SSUP may change depending on whether the actual costs of the network solution are higher or lower than the forward-looking costs.

It should be noted that while the focus is on network solutions in these examples, the same approach may apply to non-network solutions where 'locked in' contracts for non-network services no longer reflect the forward-looking costs of providing system strength services.

Formatted: Tab stops: 9.25 cm, Centered + 24 cm, Right + Not at 17.5 cm

Formatted: Tab stops: 24 cm, Right + Not at 17.5 cm

<sup>14</sup> AER, Explanatory statement, Final decision - Pricing methodology guidelines: System strength pricing 25 August 2022, page 5.



# Powerlink Pricing Methodology

Formatted Table

**Case 1 LRAC set based on 10 year forecasts, using combination of network and non-network solutions (All dollar amounts are stated in real terms)**

Year	1	2	3	4	5	6	7	8	9	10	Total	
Row 1	<b>Total System Strength requirement (MVA)</b>	<b>1000</b>	<b>1000</b>	<b>1200</b>	<b>1200</b>	<b>1500</b>	<b>1500</b>	<b>1600</b>	<b>1600</b>	<b>1800</b>	<b>1800</b>	<b>14200</b>
Row 2	Requirement met by network solutions (MVA)	500	500	500	500	1000	1000	1000	1000	1000	1000	
Row 3	Annual unit cost of network solutions (\$/MVA)	\$7,400	\$7,400	\$7,400	\$7,400	\$7,400	\$7,400	\$7,400	\$7,400	\$7,400	\$7,400	
Row 4	Annual total cost of network solutions (\$M)	\$3.7	\$3.7	\$3.7	\$3.7	\$7.4	\$7.4	\$7.4	\$7.4	\$7.4	\$7.4	\$59.2
Row 5	Requirement met by non-network solutions (MVA)	500	500	700	700	500	500	600	600	800	800	
Row 6	Annual unit cost of non-network solutions (\$/MVA)	\$8,400	\$8,200	\$8,286	\$8,214	\$8,000	\$7,900	\$7,833	\$7,667	\$7,625	\$7,500	
Row 7	Annual total cost of non-network solutions (\$M)	\$4.2	\$4.1	\$5.8	\$5.8	\$4.0	\$4.0	\$4.7	\$4.6	\$6.1	\$6.0	\$49.2
Row 8	<b>Total annual cost of meeting requirement (\$M)</b>	<b>\$7.9</b>	<b>\$7.8</b>	<b>\$9.5</b>	<b>\$9.5</b>	<b>\$11.4</b>	<b>\$11.4</b>	<b>\$12.1</b>	<b>\$12.0</b>	<b>\$13.5</b>	<b>\$13.4</b>	<b>\$108.4</b>

**SSUP is the 10-year LRAC, which is \$7,634 per MVA**  
**This price applies for years 1-5 and will be revisited for year 6 onwards**

Row 1 shows the total system strength requirement in MVA for each year, as determined by the SSSP based on needs identified by AEMO. To simplify the exposition, this example assumes that the total system strength requirement at the node is the same as the total system strength hosting capacity (SSQ x SSL) at each of the connection points served by that node. In practice, however, the sum of the total system strength hosting capacity at the connection points linked to that system strength node may exceed the total system strength requirement at the node.

In this example, the TNSP has determined that the most economic mix of resources that will meet the requirement consists of a combination of network and non-network solutions. Row 2 shows the total system strength requirement that will be met by network solutions for each year. This information is provided to illustrate the implied \$/MVA cost for the network and non-network solutions, noting that the System Strength Service Provider will plan to meet the system strength standard at the lowest total life cycle cost.

Row 3 shows the real annual cost per MVA of the network solutions for each year. The annual cost will reflect the expected economic life of the network solution.

Formatted: Tab stops: 9.25 cm, Centered + 24 cm, Right + Not at 17.5 cm

Formatted: Tab stops: 24 cm, Right + Not at 17.5 cm



# Powerlink Pricing Methodology

Formatted Table

Row 4 shows the total annual cost (in real terms) of the network solutions. It is calculated by multiplying the values in Row 2 (MVA provided by network solutions) and Row 3 (real annual cost of network solutions per MVA) for each year.

Row 5 shows the total system strength requirement in MVA to be met by non-network solutions. In each year, the amount of *system strength service* provided by non-network solutions is the difference between the total requirement and the amount provide by the network solutions.

Row 6 shows the forecast real cost of non-network solutions per unit of MVA provided in each year.

Row 7 shows the total annual cost (in real dollars) of the non-network solutions. It is calculated by multiplying the values in Row 5 (MVA provided by non-network solutions) and Row 6 (real annual cost of non-network solutions per MVA) for each year.

Row 8 shows the total annual cost of meeting the specified system strength requirement. It is calculated by summing the values in Row 4 and Row 7.

The long run average cost of meeting the specified system strength requirements is \$7,634 per MVA. It is calculated by summing the total annual cost over 10 years shown in Row 8 (\$108.4 million) and dividing that number by the sum of the total MVA of system strength services provided over the period (14,200 MVA, as shown in Row 1). As noted above, to simplify the exposition, it is assumed that the total system strength hosting capacity is the same as the system strength capacity provided at the node. In practice, the long run average cost would divide the total cost over 10 years by the total system strength hosting capacity.

Formatted: Tab stops: 9.25 cm, Centered + 24 cm, Right + Not at 17.5 cm

Formatted: Tab stops: 24 cm, Right + Not at 17.5 cm



Formatted Table

# Powerlink Pricing Methodology

The table below (Case 2) illustrates the pricing methodology at the first re-set at the end of year 5, where the forward-looking costs are lower than the actual network costs. The greyed out data does not feature in this SSUP calculation in this case.

Case 2 as per Case 1, with SSUP reset for years 6-15 with existing network solutions no longer reflecting the forward-looking costs (All dollar amounts are stated in real terms)

Year	1	2	3	4	5	6	7	8	9	10	11	12	13	14	15	Total years 6-15	
Row 1	<b>Total System Strength requirement (MVA)</b>	1000	1000	1200	1200	1500	1500	1600	1600	1800	1800	1800	2000	2300	2300	2300	19000
Row 2	Requirement met by network solutions (MVA)	500	500	500	500	1000	1000	1000	1000	1000	1000	1000	1000	1000	1000	1000	
Row 3	Annual unit cost of network solutions (\$/MVA)	\$7,400	\$7,400	\$7,400	\$7,400	\$7,400	\$7,400	\$7,400	\$7,400	\$7,400	\$7,400	\$7,400	\$7,400	\$7,400	\$7,400	\$7,400	
Row 4	Annual total cost of network solutions (\$M)	\$3.7	\$3.7	\$3.7	\$3.7	\$7.4	\$7.4	\$7.4	\$7.4	\$7.4	\$7.4	\$7.4	\$7.4	\$7.4	\$7.4	\$7.4	
Row 5	Forward-looking annual unit cost of network solutions (\$/MVA)					\$7,400	\$7,400	\$7,400	\$7,400	\$7,400	\$7,250	\$7,250	\$7,250	\$7,250	\$7,250		
Row 6	<b>Forward-looking annual total cost of network solution (\$M)</b>					\$7.4	\$7.4	\$7.4	\$7.4	\$7.4	\$7.3	\$7.3	\$7.3	\$7.3	\$7.3	\$7.3	\$73.3
Row 7	Requirement met by non-network solution (MVA)	500	500	700	700	500	500	600	600	800	800	800	1000	1300	1300	1300	
Row 8	Annual unit cost of non-network solution (\$/MVA)	\$8,400	\$8,200	\$8,286	\$8,214	\$8,000	\$7,900	\$7,833	\$7,667	\$7,625	\$7,500	\$7,300	\$7,200	\$7,000	\$6,750	\$6,700	
Row 9	<b>Annual total cost of non-network solution (\$M)</b>	\$4.2	\$4.1	\$5.8	\$5.8	\$4.0	\$4.0	\$4.7	\$4.6	\$6.1	\$6.0	\$5.8	\$7.2	\$9.1	\$8.8	\$8.7	\$65.0
Row 10	<b>Total annual cost of meeting requirement (\$M)</b>	\$7.9	\$7.8	\$9.5	\$9.5	\$11.4	\$11.4	\$12.1	\$12.0	\$13.5	\$13.4	\$13.1	\$14.5	\$16.4	\$16.0	\$16.0	\$138.2

As per case 1, the annual SSUP is set at \$7,634 per MVA for years 1-5 based on LRAC for years 1-10.  
 SSUP is reset in year 6 at \$7,275 per MVA based on the LRAC for years 6-15

Formatted: Tab stops: 9.25 cm, Centered + 24 cm, Right + Not at 17.5 cm  
 Formatted: Tab stops: 24 cm, Right + Not at 17.5 cm



# Powerlink Pricing Methodology

Formatted Table

In this example, at the end of year 5, the forecast costs of meeting the specified system strength requirements for the next 10 years are assessed. In this example, the costs of the network and non-network solutions for years 6 to 10 are unchanged from the initial assessment (shown in Case 1). Over years 11 to 15, the forecast unit costs of non-network solutions (shown in Row 8) are expected to fall.

It is estimated that the most cost-effective system strength resource that would be available to meet the remaining requirement (which will be met by network solutions) has a cost of \$7,250/MVA/year. Accordingly, the annual unit cost of the network solutions is adjusted down from \$7,400/MVA (Row 3) to \$7,250/MVA (Row 5). For the purpose of calculating the 10 year LRAC for years 6 to 15, the reduced forward-looking cost of the network solutions is adopted.<sup>15</sup> Accordingly, the values in Rows 3 and 4 for years 11 to 15 are shaded grey and excluded from the calculations, while the values in Rows 5 and 6 are used in the calculations instead.

The long run average cost of meeting the specified system strength requirements over years 6 to 15 is \$7,275 per MVA. It is calculated as the sum of the total annual costs over the period from years 6 to 15 (Row 10, \$138.2 million) divided by the sum of the system strength requirements over the same period (Row 1, 19,000). This cost is lower than the \$7,634/MVA/year calculated for the initial 10 year period, reflecting:

- the forecast reduction in the unit cost of non-network solutions over years 11 to 15; and
- the reduction in the forward-looking cost of network solutions for years 11 to 15.

As noted in relation to case 1, the above exposition has been simplified by assuming that the total system strength hosting capacity is the same as the system strength capacity provided at the node.

<sup>15</sup> Conversely, if the forward-looking annual costs were, say, \$8,000 per MVA, compared to Powerlink's actual annual costs of \$7,400 per MVA, the lower costs would be adopted.

Formatted: Tab stops: 9.25 cm, Centered + 24 cm, Right + Not at 17.5 cm

Formatted: Tab stops: 24 cm, Right + Not at 17.5 cm

<b>Page xiv: [1] Formatted</b>	<b>Author</b>
Default Paragraph Font	
<b>Page xiv: [1] Formatted</b>	<b>Author</b>
Default Paragraph Font	
<b>Page xiv: [2] Formatted</b>	<b>Author</b>
Default Paragraph Font	
<b>Page xiv: [2] Formatted</b>	<b>Author</b>
Default Paragraph Font	
<b>Page xiv: [3] Formatted</b>	<b>Author</b>
Default Paragraph Font	
<b>Page xiv: [3] Formatted</b>	<b>Author</b>
Default Paragraph Font	
<b>Page xiv: [4] Formatted</b>	<b>Author</b>
Default Paragraph Font	
<b>Page xiv: [4] Formatted</b>	<b>Author</b>
Default Paragraph Font	
<b>Page xiv: [5] Formatted</b>	<b>Author</b>
Default Paragraph Font	
<b>Page xiv: [5] Formatted</b>	<b>Author</b>
Default Paragraph Font	
<b>Page xiv: [6] Formatted</b>	<b>Author</b>
Default Paragraph Font	
<b>Page xiv: [6] Formatted</b>	<b>Author</b>
Default Paragraph Font	
<b>Page xiv: [7] Formatted</b>	<b>Author</b>
Default Paragraph Font	
<b>Page xiv: [7] Formatted</b>	<b>Author</b>
Default Paragraph Font	
<b>Page xiv: [8] Formatted</b>	<b>Author</b>
Default Paragraph Font	
<b>Page xiv: [8] Formatted</b>	<b>Author</b>
Default Paragraph Font	
<b>Page xiv: [9] Formatted</b>	<b>Author</b>
Default Paragraph Font	
<b>Page xiv: [9] Formatted</b>	<b>Author</b>
Default Paragraph Font	
<b>Page xiv: [10] Formatted</b>	<b>Author</b>
Default Paragraph Font	
<b>Page xiv: [10] Formatted</b>	<b>Author</b>
Default Paragraph Font	
<b>Page xiv: [11] Formatted</b>	<b>Author</b>
Default Paragraph Font	
<b>Page xiv: [11] Formatted</b>	<b>Author</b>

Default Paragraph Font

**Page xiv: [12] Formatted** **Author**

Default Paragraph Font

**Page xiv: [12] Formatted** **Author**

Default Paragraph Font

**Page xiv: [13] Formatted** **Author**

Default Paragraph Font

**Page xiv: [13] Formatted** **Author**

Default Paragraph Font

**Page xiv: [14] Formatted** **Author**

Default Paragraph Font

**Page xiv: [14] Formatted** **Author**

Default Paragraph Font

**Page xiv: [15] Formatted** **Author**

Default Paragraph Font, Font: Not Bold, Not Italic, Check spelling and grammar

**Page xiv: [15] Formatted** **Author**

Default Paragraph Font, Font: Not Bold, Not Italic, Check spelling and grammar

**Page xiv: [16] Formatted** **Author**

Default Paragraph Font, Font: Not Bold, Not Italic, Check spelling and grammar

**Page xiv: [16] Formatted** **Author**

Default Paragraph Font, Font: Not Bold, Not Italic, Check spelling and grammar

**Page xiv: [17] Formatted** **Author**

Default Paragraph Font, Font: Not Bold, Not Italic, Check spelling and grammar

**Page xiv: [17] Formatted** **Author**

Default Paragraph Font, Font: Not Bold, Not Italic, Check spelling and grammar

**Page xiv: [18] Formatted** **Author**

Default Paragraph Font, Font: Not Bold, Not Italic, Check spelling and grammar

**Page xiv: [18] Formatted** **Author**

Default Paragraph Font, Font: Not Bold, Not Italic, Check spelling and grammar

**Page xiv: [19] Formatted** **Author**

Default Paragraph Font, Font: Not Bold, Not Italic, Check spelling and grammar

**Page xiv: [19] Formatted** **Author**

Default Paragraph Font, Font: Not Bold, Not Italic, Check spelling and grammar

**Page xiv: [20] Formatted** **Author**

Default Paragraph Font

**Page xiv: [20] Formatted** **Author**

Default Paragraph Font

**Page xiv: [21] Formatted** **Author**

Default Paragraph Font, Font: Not Bold, Not Italic, Check spelling and grammar

**Page xiv: [21] Formatted** **Author**

Default Paragraph Font, Font: Not Bold, Not Italic, Check spelling and grammar

**Page xiv: [22] Formatted** **Author**

Default Paragraph Font, Font: Not Bold, Not Italic, Check spelling and grammar



**Page xiv: [22] Formatted** **Author**

Default Paragraph Font, Font: Not Bold, Not Italic, Check spelling and grammar

**Page xiv: [23] Formatted** **Author**

Default Paragraph Font, Font: Not Bold, Not Italic, Check spelling and grammar

**Page xiv: [23] Formatted** **Author**

Default Paragraph Font, Font: Not Bold, Not Italic, Check spelling and grammar

**Page xiv: [24] Formatted** **Author**

Default Paragraph Font, Font: Not Bold, Not Italic, Check spelling and grammar

**Page xiv: [24] Formatted** **Author**

Default Paragraph Font, Font: Not Bold, Not Italic, Check spelling and grammar

**Page xiv: [25] Formatted** **Author**

Default Paragraph Font

**Page xiv: [25] Formatted** **Author**

Default Paragraph Font

**Page xiv: [26] Formatted** **Author**

Default Paragraph Font, Font: Not Bold, Not Italic, Check spelling and grammar

**Page xiv: [26] Formatted** **Author**

Default Paragraph Font, Font: Not Bold, Not Italic, Check spelling and grammar

**Page xiv: [27] Formatted** **Author**

Default Paragraph Font, Font: Not Bold, Not Italic, Check spelling and grammar

**Page xiv: [27] Formatted** **Author**

Default Paragraph Font, Font: Not Bold, Not Italic, Check spelling and grammar

**Page xiv: [28] Formatted** **Author**

Default Paragraph Font

**Page xiv: [28] Formatted** **Author**

Default Paragraph Font

**Page xiv: [29] Formatted** **Author**

Default Paragraph Font

**Page xiv: [29] Formatted** **Author**

Default Paragraph Font

**Page xiv: [30] Formatted** **Author**

Default Paragraph Font

**Page xiv: [30] Formatted** **Author**

Default Paragraph Font

**Page xiv: [31] Formatted** **Author**

Default Paragraph Font

**Page xiv: [31] Formatted** **Author**

Default Paragraph Font

**Page xiv: [32] Formatted** **Author**

Default Paragraph Font

**Page xiv: [32] Formatted** **Author**

Default Paragraph Font

**Page xiv: [33] Formatted** **Author**

Default Paragraph Font

**Page xiv: [33] Formatted** **Author**

Default Paragraph Font

**Page xiv: [34] Formatted** **Author**

Default Paragraph Font

**Page xiv: [34] Formatted** **Author**

Default Paragraph Font

**Page xiv: [35] Formatted** **Author**

Default Paragraph Font

**Page xiv: [35] Formatted** **Author**

Default Paragraph Font

**Page xiv: [36] Formatted** **Author**

Default Paragraph Font

**Page xiv: [36] Formatted** **Author**

Default Paragraph Font

**Page xv: [37] Formatted** **Author**

Default Paragraph Font, Check spelling and grammar

**Page xv: [38] Formatted** **Author**

Default Paragraph Font, Check spelling and grammar

**Page xv: [39] Formatted** **Author**

Default Paragraph Font, Check spelling and grammar

**Page xv: [40] Formatted** **Author**

Default Paragraph Font, Check spelling and grammar

**Page xv: [41] Formatted** **Author**

Default Paragraph Font, Font: Not Bold, Check spelling and grammar