

2023-27

POWERLINK QUEENSLAND  
REVENUE PROPOSAL

Appendix 5.02 – PUBLIC

2020

Transmission Annual Planning Report

© Copyright Powerlink Queensland 2021



# 2020

## Transmission Annual Planning Report





Please direct Transmission Annual Planning Report (TAPR) enquiries to:

Stewart Bell  
A/Executive General Manager  
Strategy and Business Development Division  
Powerlink Queensland

Telephone: (07) 3860 2801  
Email: [sbell@powerlink.com.au](mailto:sbell@powerlink.com.au)

**Disclaimer:** While care is taken in the preparation of the information in this report, and it is provided in good faith, Powerlink Queensland accepts no responsibility or liability for any loss or damage that may be incurred by persons acting in reliance on this information or assumptions drawn from it.

## Table of contents

Executive summary	7
<b>I. Introduction</b>	<b>15</b>
I.1 Introduction	16
I.2 Context of the TAPR	16
I.3 Purpose of the TAPR	17
I.4 Role of Powerlink Queensland	17
I.5 Meeting the challenges of a transitioning energy system	18
I.6 Overview of approach to asset management	19
I.7 Overview of planning responsibilities and processes	19
I.7.1 Planning criteria and processes	19
I.7.2 Integrated planning of the shared network	20
I.7.3 Joint planning	22
I.7.4 Connections	23
I.7.5 Interconnectors	23
I.8 Powerlink’s asset planning criteria	23
I.9 Powerlink’s reinvestment criteria	24
I.10 Stakeholder engagement	25
I.10.1 Customer and stakeholder engagement	25
I.10.2 Non-network solutions	27
I.10.3 Focus on continuous improvement	28
<b>2. Energy and demand projections</b>	<b>29</b>
2.1 Overview	30
2.2 Customer consultation	34
2.3 Demand forecast outlook	35
2.3.1 Changing load profiles	36
2.3.2 Demand and energy terminology	37
2.3.3 Energy forecast	39
2.3.4 Summer maximum demand forecast	41
2.3.5 Winter maximum demand forecast	43
2.3.6 Summer minimum demand forecast	45
2.3.7 Winter minimum demand forecast	47
2.4 Zone forecasts	49
2.5 Summer and winter minimum and maximum daily profiles	56
2.6 Annual load duration curves	58
<b>3. Joint Planning</b>	<b>59</b>
3.1 Introduction	60
3.2 Working groups and regular engagement	60
3.2.1 Regular joint planning meetings	61
3.3 AEMO ISP	61
3.4 AEMO National Planning – Fault Level Shortfall	62
3.5 Power System Frequency Risk Review (PSFRR)	62
3.6 Joint planning with TransGrid – Expanding the transmission transfer capacity between New South Wales and Queensland	63
3.7 Joint planning with Energex and Ergon Energy	64
3.7.1 Matters requiring joint planning	64

# Contents

4.	Asset management overview	65
4.1	Introduction	66
4.2	Overview of approach to asset management	66
4.3	Asset Management Policy	67
4.4	Asset Management Strategy	67
4.4.1	Asset life cycle	68
4.4.2	Asset management cycle	68
4.5	Asset management methodologies	69
4.6	Flexible and integrated network investment planning	70
4.7	Asset management implementation	70
4.8	Further information	70
5.	Future network development	71
5.1	Introduction	72
5.2	ISP alignment	73
5.3	Flexible and integrated approach to network development	74
5.4	Forecast capital expenditure	75
5.5	Forecast network limitations	75
5.5.1	Summary of forecast network limitations within the next five years	76
5.5.2	Summary of forecast network limitations beyond five years	76
5.6	Consultations	76
5.6.1	Current consultations – proposed transmission investments	77
5.6.2	Future consultations – proposed transmission investments	79
5.6.3	Connection point proposals	80
5.7	Proposed network developments	80
5.7.1	Far North zone	84
5.7.2	Ross zone	92
5.7.3	North zone	97
5.7.4	Central West zone	100
5.7.5	Gladstone zone	105
5.7.6	Wide Bay zone	110
5.7.7	South West zone	115
5.7.8	Surat zone	118
5.7.9	Bulli zone	120
5.7.10	Moreton zone	121
5.7.11	Gold Coast zone	130
5.7.12	Supply demand balance	135
5.7.13	Existing interconnectors	135
5.7.14	Expanding NSW-Queensland transmission transfer capacity	136
6.	Network capability and performance	137
6.1	Introduction	138
6.2	Available generation capacity	139
6.2.1	Existing and committed transmission connected and direct connect embedded generation	139
6.2.2	Existing and committed scheduled and semi-scheduled distribution connected embedded generation	142

6.3	Network control facilities _____	144
6.4	Existing network configuration _____	145
6.5	Transfer capability _____	150
6.5.1	Location of grid sections _____	150
6.5.2	Determining transfer capability _____	150
6.6	Grid section performance _____	150
6.6.1	Far North Queensland (FNQ) grid section _____	154
6.6.2	Central Queensland to North Queensland (CQ-NQ) grid section _____	155
6.6.3	NQ System Strength _____	158
6.6.4	Gladstone grid section _____	159
6.6.5	CQ-SQ grid section _____	161
6.6.6	Surat grid section _____	162
6.6.7	South West Queensland (SWQ) grid section _____	163
6.6.8	Tarong grid section _____	165
6.6.9	Gold Coast grid section _____	166
6.6.10	QNI and Terranora Interconnector _____	168
6.7	Zone performance _____	169
6.7.1	Far North zone _____	169
6.7.2	Ross zone _____	170
6.7.3	North zone _____	171
6.7.4	Central West zone _____	172
6.7.5	Gladstone zone _____	173
6.7.6	Wide Bay zone _____	175
6.7.7	Surat zone _____	177
6.7.8	Bulli zone _____	177
6.7.9	South West zone _____	178
6.7.10	Moreton zone _____	180
6.7.11	Gold Coast zone _____	181
<b>7.</b>	<b>Strategic planning _____</b>	<b>183</b>
7.1	Introduction _____	184
7.2	Challenges of falling minimum demand _____	185
7.3	Possible network options to meet reliability obligations for potential new loads _____	187
7.3.1	Bowen Basin coal mining area _____	188
7.3.2	Bowen Industrial Estate _____	188
7.3.3	Galilee Basin coal mining area _____	189
7.3.4	CQ-NQ grid section transfer limit _____	189
7.3.5	Surat Basin north west area _____	190
7.4	Impact of the energy transformation _____	191
7.4.1	Queensland to NSW Interconnector (QNI) _____	192
7.4.2	CQ-SQ grid section reinforcement _____	193
7.4.3	Gladstone grid section reinforcement _____	194
7.4.4	Renewable Energy Zones (REZ) _____	195
<b>8.</b>	<b>Renewable energy _____</b>	<b>197</b>
8.1	Introduction _____	198
8.2	Management of system strength and NER obligations _____	199
8.2.1	Investigation into system strength frameworks by AEMC _____	200
8.3	Developing an understanding of the system strength challenges _____	201

# Contents

8.3.1	Australian Renewable Energy Agency (ARENA) Project	201
8.3.2	Retuning of transmission connected Static VAr Compensators (SVCs)	202
8.3.3	Inverter level retuning of VRE plant	202
8.4	Declaration of fault level shortfall	202
8.4.1	Options to address the fault level shortfall	203
8.5	Transmission connection and planning arrangements	204
8.6	Indicative available network capacity – Generation Capacity Guide (GCG)	204
8.6.1	Full Impact Assessment (FIA)	205
8.7	System strength during network outages	205
8.8	Transmission congestion and Marginal Loss Factors (MLF)	205
8.9	Further information	206
9.	Committed, current and recently commissioned network developments	207
9.1	Transmission network	208
	Appendices	215
	Appendix A Forecast of connection point maximum demands	216
	Appendix B TAPR templates	221
	Appendix C Zone and grid section definitions	224
	Appendix D Limit equations	228
	Appendix E Indicative short circuit currents	236
	Appendix F Compendium of potential non-network solution opportunities within the next five years	244
	Appendix G Glossary	248

## Executive summary

Planning and development of the transmission network is integral to Powerlink Queensland meeting its obligations under the National Electricity Rules (NER), Queensland's Electricity Act 1994 and its Transmission Authority.

The Transmission Annual Planning Report (TAPR) is a key part of the planning process and provides stakeholders and customers with important information about the existing and future transmission network in Queensland. The report is targeted at those interested or involved in the National Electricity Market (NEM) including the Australian Energy Market Operator (AEMO), Registered Participants and interested parties. The TAPR also provides stakeholders with an overview of Powerlink's planning processes and decision making on potential future investments.

The TAPR includes information on electricity energy and demand forecasts, committed generation and network developments. It also provides estimates of transmission grid capability and potential network and non-network developments required in the future to continue to meet electricity demand in a timely manner and provide a valued service to our customers.

## Overview

The 2020 TAPR outlines the key factors impacting Powerlink's transmission network development and operations and discusses how Powerlink continues to adapt and respond to dynamic changes in the external environment to meet the challenges of a rapidly transitioning energy system.

The forecasts presented in this TAPR indicate low growth for summer maximum demand and a decline in delivered energy for the transmission network over the 10-year outlook period.

The Queensland transmission network experienced significant growth in the period from the 1960s to the 1980s. The capital expenditure required to manage emerging risks related to assets now reaching the end of technical service life represents the majority of Powerlink's program of work over the outlook period. In line with customer and stakeholder expectations, emphasis will be placed on ensuring that asset reinvestment considers the enduring need and most cost effective option. Network planning studies have focussed on evaluating the enduring need for existing assets and potentially the need for new assets to ensure network resilience in the context of increasing diversity of generation, a relatively flat demand growth outlook and the potential for network reconfiguration, coupled with alternative non-network solutions.

Powerlink's focus on customer and stakeholder engagement has continued over the past year, with a range of activities undertaken to seek feedback and input into our network investment decision making and planning.

This included holding the 2019 Transmission Network Forum, incorporating related interactive feedback sessions on using non-network solutions to reduce short-term demand peaks and renewable connections and the future transmission network. The 2020 Transmission Network Forum was held in an online format in early September to inform customers and stakeholders on longer term power system planning and the challenges of the energy transition. A key focus of discussion at the 2020 forum included the Queensland Government announcement in early September of \$500 million in funding to support Renewable Energy Zone (REZ) development, in addition to \$145 million previously announced for REZ support. Stakeholders and customers support Powerlink continuing to work closely with Government in relation to allocation of this funding, which will play a key role in driving economic recovery post the COVID-19 pandemic.

Since 2018, Powerlink as the founding participant, has committed to the whole-of-sector Energy Charter initiative. The Charter is focussed on driving a customer-centric culture and conduct in energy businesses to deliver service improvements for the benefit of customers.



# Executive Summary

## Electricity energy and demand forecasts

The 2019/20 summer in Queensland had above average daily maximum and minimum temperatures, particularly in the earlier summer months, which saw a new monthly maximum delivered demand (refer to Figure 2.6 for load measurement definitions) for the month of January 2020 and an overall summer peak delivered demand of 8,766MW at 6:00pm on 3 February 2020. Operational 'as generated' and native maximum annual demands were recorded at 5:30pm on 3 February 2020, with operational 'as generated' reaching 9,853MW, and native demand of 9,214MW. After temperature correction, the 2019/20 summer maximum delivered demand was 8,605MW, 0.2% higher than the 2019 TAPR forecast.

Since March 2020 the COVID-19 pandemic has reduced delivered energy consumption on Powerlink's transmission network by an estimated 2.2%.

The 2020 Queensland minimum delivered demand occurred at 12:30pm on 27 September 2020, when only 3,003MW was delivered from the transmission grid. Operational 'as generated' minimum demand was recorded 30 minutes earlier at 12:00pm dropping to 3,860MW. Direct connect loads made up about two-thirds of the demand with Distribution Network Service Providers (DNSPs) customers only making up one-third. Mild weather conditions, during a weekend (Sunday) in combination with strong contribution from rooftop photovoltaic (PV) were contributors to this record minimum demand.

Powerlink has adopted AEMO's 2020 ESOO forecasts in its planning analysis for the 2020 TAPR. The forecast captures the impacts of the COVID-19 pandemic, growth in rooftop PV installations, changing Queensland economic growth conditions, energy efficiency initiatives, battery storage and tariffs through Central, Slow Change and Step Change scenarios. Bottom-up forecasts are derived through reconciliation of AEMO's forecast with those from DNSPs at each transmission connection supply point.

## Electricity energy forecast

Based on the Central scenario, Queensland's delivered energy consumption is forecast to decrease at an average of 0.7% per annum over the next 10 years from 47,860GWh in 2019/20 to 44,413GWh in 2029/30. The reduction is due to anticipated increases in the capacity of distribution connected renewable generation and rooftop PV.

## Electricity demand forecast

Based on the Central scenario, Queensland's transmission delivered summer maximum demand is forecast to increase at an average rate of 0.7% per annum over the next 10 years, from 8,605MW (weather corrected) in 2019/20 to 9,236MW in 2029/30. Winter minimum transmission delivered demands are expected to decrease at an average rate of 10.5% per annum, from 3,003MW in 2020 to 988MW in 2030.

## Changing load profiles

The progressive installation of rooftop PV solar systems and distribution connected solar farms has seen a continued decrease of Queensland transmission delivered demand during the day time. The daily demand profile now tends to follow the characteristic duck curve shape, and this is particularly evident during the winter and spring seasons. Queensland delivered demand during the day is now lower than the night time for a portion of the year, and voltage control devices historically installed to manage light load during the night may no longer be sufficient to manage voltages during the day. The installation of reactive control devices or non-network solutions will be required for voltage control during day time minimum demand periods.

The uptake of embedded PV solar installations is expected to continue, and this will present further challenges to the energy system. Decreasing minimum demand may lower the amount of synchronous generation that is online and this could further impact on voltage control, system strength and inertia. There may be opportunities for innovative technologies and storage solutions to assist with smoothing the daily load profile. These type of services could offer a number of benefits to the energy system including reducing the need for additional transmission investment.

## Future network development

Shifts in customer expectation and dynamic changes in the external environment which is transitioning to a power system with much greater levels of variable renewable energy (VRE) generation, is reshaping the operating environment in which Powerlink delivers its transmission services. In response to these challenges, Powerlink is focussing on an integrated approach to long-term planning, including the potential development of suitable REZs in Queensland.

In addition, initiatives such as the Integrated System Plan (ISP) inform the future development of the power system and the associated network topography of the transmission network in Queensland and the NEM over the 20-year outlook period or 10-year outlook period of this TAPR.

As well as responding to the ongoing impacts of the COVID-19 pandemic in 2020, Powerlink is also continuing to:

- undertake ongoing active customer and stakeholder engagement for informed decision making and planning
- implement and adopt the recommendations of various market reviews
- adapt to changes in customer behaviour and economic outlook
- ensure its approach to investment decisions delivers positive outcomes for customers
- place considerable emphasis on an integrated, flexible and holistic analysis of future investment needs
- support diverse generation connections
- ensure compliance with changes in legislation, regulations and operating standards
- focus on developing options that deliver a secure, safe, reliable and cost effective transmission network.

Based on the central scenario, the planning standard and committed network solutions, there are no significant network augmentations to meet load growth forecast to occur within the 10-year outlook period of this TAPR.

There are proposals for large mining, metal processing and other industrial loads that have not reached a committed development status. These new large loads are within the resource rich areas of Queensland and associated coastal port facilities. These loads have the potential to significantly impact the performance of the transmission network supplying, and within, these areas. Within this TAPR, Powerlink has outlined the potential network investment required in response to these loads emerging in line with a high economic outlook.

Since January 2016, Queensland has seen an unprecedented level of renewable energy investment activity in Queensland. These investments in VRE generation are changing the energy flows on the transmission network and have increased the utilisation of the Central West to Gladstone and Central Queensland (CQ) to South Queensland (CQ-SQ) grid sections. Depending on the emergence of network limitations it may become economically viable to increase the power transfer capacity to alleviate constraints across these grid sections. Feasible network solutions are outlined within the TAPR.

The Queensland transmission network experienced significant growth in the period from the 1960s to the 1980s. The capital expenditure needed to manage the condition risks related to this asset base, some of which is now reaching end of technical service life, represents the bulk of Powerlink's program of work within the outlook period.

Considerable emphasis has been given to a flexible and integrated approach to the analysis of future reinvestment needs and options. Powerlink has systematically assessed the enduring need for assets at the end of their technical service life taking into account future renewable generation and considered a broad range of options including network reconfiguration, asset retirement, non-network solutions or replacement with an asset of lower capacity. This incremental development approach potentially defers large capital investment and has the benefit of maintaining the existing topography, transfer capability and operability of the transmission network.

## Renewable energy and generation capacity

To date Powerlink has completed connection of 13 large-scale solar and wind farm projects in Queensland, adding 1,630MW of generation capacity to the grid. During 2019/20 30 connection applications, totalling about 6,400MW of new generation capacity, have been received and are at varying stages of progress. This includes connection agreements for a further 1,338MW of VRE.

# Executive Summary

To ensure that any adverse system strength impact is adequately addressed, Powerlink is working with customers, suppliers and AEMO to enhance its integrated system strength model for the Queensland transmission network. This work has provided important insights into the extreme complexity of system strength and how it impacts on managing asynchronous connections and the network in general.

Powerlink will apply this integrated system strength model to existing and new connection applications and engage with renewables sector customers to better understand the potential for additional VRE generation in Queensland.

## Grid section and zone performance

During 2019/20, the Powerlink transmission network performed reliably. Record transmission delivered demand was recorded for Central West, Surat and Bulli zones.

Inverter-based resources in northern Queensland experienced approximately 650 hours of constrained operation during 2019/20. Powerlink is in the process of addressing a system strength shortfall that was declared by AEMO in April 2020.

The CQ-SQ grid section was highly utilised during 2019/20, reflecting higher generation levels in northern Queensland as a result of recently commissioned VRE generators.

## Consultation on network reinvestments

Powerlink is committed to regularly reviewing and developing its transmission network in a timely manner to meet the required levels of reliability and manage the risks arising from aged assets remaining in-service.

Following the Replacement Expenditure Planning Arrangements Rule, which commenced in September 2017, Powerlink continues to make considerable progress in its Regulatory Investment Test for Transmission (RIT-T) program in relation to the replacement of network assets, finalising nine RIT-Ts in this category since the publication of the 2019 TAPR (refer to Chapter 9).

In addition, Powerlink commenced a consultation to seek expressions of interest for system strength services in Queensland to address the fault level shortfall at Ross declared by AEMO in April 2020.

The TAPR also highlights anticipated upcoming RIT-Ts for which Powerlink intends to seek solutions and/or initiate consultation with AEMO, Registered Participants and interested parties in the near future (refer to Section 5.6.2). To enhance the value and outcomes of the RIT-T process to customers, Powerlink undertakes a range of engagement activities for each RIT-T, determined on a case-by-case basis. This engagement matrix for RIT-Ts was developed in consultation with Powerlink's Customer Panel.

## Expanding New South Wales to Queensland transmission transfer capacity

A RIT-T process to consider investment options on the Queensland/New South Wales Interconnector (QNI) commenced in November 2018 and was completed in December 2019 with the publication of the ['Expanding NSW-Queensland transmission transfer capacity'](#) Project Assessment Conclusion Report (PACR). This RIT-T focussed on consideration of the 2018 ISP recommended Group 1 QNI 'minor' upgrade and investigated the near-term options to increase overall net market benefits in the NEM through relieving congestion on the transmission network between New South Wales (NSW) and Queensland. The PACR identified upgrading the Liddell to Tamworth transmission lines, installing new dynamic reactive support at Tamworth and Dumaresq, and shunt capacitor banks at Tamworth, Dumaresq and Armidale as the preferred option which is expected to deliver the greatest net benefits. These works are anticipated to be completed by 2022, prior to the closure of Liddell Power Station. Powerlink and TransGrid are investigating the potential benefits of further increases to transmission capacity provided by the QNI 'minor upgrade'.

The 2020 ISP identified further upgrades to the QNI capacity as part of the optimal development path which would reduce costs and enhance system resilience. The future project was not yet identified as 'actionable', but may be so in the future. The proposed project is a staged 500kV line upgrade to share renewable energy, storage, and firming services between the regions after the closure of Eraring or to support REZ developments. Each stage is a 500kV line; the first forecast for completion by 2032-33 and the second by 2035-36.

## Future ISP projects in Queensland

The 2020 ISP identified further upgrades in Queensland as part of the optimal development path in the NEM. These future ISP projects, anticipated to become 'actionable' in a future ISP include:

- QNI Medium and Large interconnector upgrades (Powerlink and TransGrid consultation)
- Central to Southern Queensland Transmission Link
- Gladstone Grid Reinforcement

Preparatory activities for these projects will be provided by 30 June 2021 to inform the development of the 2022 ISP.

## System strength services to address fault level shortfall at Ross

Powerlink issued a [request for system strength services](#) in April 2020 seeking Expressions of interest (EOI) from market participants for offers for system strength remediation services for a fault level shortfall declared by AEMO at the Ross node. Powerlink received a very positive response to the EOI offering a range of system strength support services and have been working closely with AEMO on the proposed remediation approach. AEMO approved the approach for the short-term, up until the end of December 2020, and Powerlink has entered into a short-term agreement with CleanCo Queensland to provide system strength services through utilising its assets in FNQ.

In addition, during August 2020 AEMO provided preliminary confirmation that, subject to the final exchange of modelling and other details, inverter tuning could reduce the overall system strength requirement at Ross. Consequently Powerlink has entered into an agreement with Daydream, Hamilton, Hayman and Whitsunday Solar Farms in northern Queensland to validate the expected positive benefits of inverter tuning.

Powerlink will continue to work closely with proponents of non-network solutions and AEMO to develop more complete and technically feasible short and long-term solutions to the System Strength Shortfall and undertake the relevant formal approval process in accordance with the NER when the optimal solution has been identified.

# Executive Summary

## Committed and commissioned projects

During 2019/20, having finalised the necessary regulatory processes for the proposed replacement of network assets, the committed projects for reinvestment across Powerlink's network include:

- Kamerunga Substation replacement
- Woree secondary systems and Static VAr Compensator (SVC) secondary systems replacement
- Ingham South transformers replacement
- Ross 275/132kV primary plant replacement
- Dan Gleeson secondary systems replacement
- Townsville South primary plant replacement
- Lilyvale primary plant and transformer replacement
- Egans Hill to Rockhampton transmission line refit
- Bouldercombe primary plant and transformer replacement
- Baralaba secondary systems replacement
- Palmwoods secondary systems replacement
- Tarong secondary systems replacement
- Belmont secondary systems replacement
- Abermain secondary systems replacement
- Line refit works between Townsville South and Clare South substations.

Projects completed in 2019/20 include reinvestment works at:

- Garbutt Substation
- Dysart Substation
- Rocklea Substation
- Line refit works on the 132kV transmission line between Collinsville North and Proserpine substations.

## Stakeholder consultation for non-network solutions

Powerlink engages with non-network providers to expand the potential use of non-network solutions, addressing the future needs of the transmission network, where technically and economically feasible. These may be in the form of an alternative option to like-for-like replacements, as a partial solution in conjunction with a network solution, or to complement an overall network reconfiguration strategy. Non-network solutions such as demand side management (DSM) will be essential in future years to avoid or delay the need to augment the transmission network in response to any increase in maximum demand.

Since the publication of the 2019 TAPR, Powerlink has continued to engage with non-network providers, customers and other stakeholders. Powerlink also participated in a large number of informal discussions with potential non-network solution providers during April/May 2020 in relation to the EOI for system strength services in Queensland to address the fault level shortfall at Ross to provide clarification and support prior to the lodgement of formal submissions. Sharing information and seeking customer input through activities such as the Transmission Network Forum, webinars and informal meetings assists in broadening customer and stakeholder understanding of our business and provides additional opportunities to seek input on potential non-network solutions.

## Customer and stakeholder engagement

Powerlink is committed to proactively engaging with stakeholders and customers and seeking their input into business processes and decision-making. All engagement activities are undertaken in accordance with our Stakeholder Engagement Framework that sets out the principles, objectives and outcomes Powerlink seeks to achieve in our interactions. In particular, Powerlink undertakes a comprehensive bi-ennial stakeholder survey to gain insights about stakeholder perceptions of key factors, its social licence to operate and reputation. Most recently completed as a 'pulse check' survey in November 2019, it provides comparisons between baseline research undertaken in 2012 and year-on-year trends to inform engagement strategies with individual stakeholders. The latest survey also sought specific insights from existing directly-connected customers and renewable proponents on aspects of customer service and delivery, and Powerlink's responsiveness.

Since the publication of the 2019 TAPR, Powerlink has engaged with stakeholders and customers in various ways through a range of forums. In September 2019, more than 100 customer, community advocacy group, government and industry representatives attended Powerlink's annual Transmission Network Forum. The forum provided updates on the state of the network and 2019 TAPR highlights, followed by interactive breakout sessions on using non-network solutions to reduce short-term demand peaks and managing renewable connections in the transmission network of the future. Powerlink held its 2020 Transmission Network Forum in an online format in early September attended by approximately 250 people, with topics including longer term power system planning and the challenges of the energy transition.

Powerlink hosts a Customer Panel that provides an interactive forum for our stakeholders and customers to give input and feedback to Powerlink regarding our decision making, processes and methodologies. The panel met in July and February 2020, and December, August and June 2019. Key topics for discussion included the upcoming Revenue Determination process, transmission pricing consultation and Powerlink's first Energy Charter Disclosure Statement to customers and stakeholders. The panel was also engaged to provide input on the asset reinvestment criteria, which enabled Powerlink to refine the criteria with customer input.

Powerlink recognises the importance of transparency for stakeholders and customers, particularly when undertaking transmission network planning and engaging in public consultation under the RIT-T process. A major stakeholder activity undertaken for RIT-Ts since the publication of the 2019 TAPR was the expanding NSW – Queensland transmission transfer capacity RIT-T stakeholder webinar.

Powerlink and TransGrid held a joint webinar in October 2019 to share the findings contained in the Project Assessment Draft Report (PADR), Expanding NSW-Queensland Transmission Transfer Capacity 'minor' Group I 2018 ISP actionable project, as the second stage of the RIT-T process. The webinar provided an opportunity outside of the formal consultation process to engage with and respond to questions from a wide range of stakeholders including consumer advocates, customer representatives, and market participants. This RIT-T has since been completed (refer to Section 5.7.14).

Powerlink intends to host a webinar in late 2020 to share the TAPR's highlights and key updates with customers and stakeholders.

## Focus on continuous improvement in the TAPR

As part of Powerlink's commitment to continuous improvement, the 2020 TAPR continues to focus on an integrated approach to future network development and contains detailed discussion on key areas of future expenditure.

# Executive Summary

The 2020 TAPR:

- discusses emerging challenges as the network transitions to much greater levels of VRE generation (Chapters 2, 5, 7 and 8)
- provides information in relation to joint planning and Powerlink's approach to asset management (refer to Chapters 3 and 4)
- discusses possible future network asset investments for the 10-year outlook period (refer to Chapter 5)
- includes the most recent information for the proposed replacement of network assets which are anticipated to be subject to the RIT-T in the next five years (refer to Chapter 5)
- continues the discussion on the potential for generation developments (in particular VRE generation) first introduced in 2016 (refer to Chapter 8)
- contains a quick reference guide on where to locate information on potential non-network opportunities in the TAPR, grouped by investment type (refer to Appendix F) and discusses Powerlink's approach to assisting the development of non-network solutions – specifically, through the ongoing improvement of engagement practices for non-network solution providers and provision of information (refer to sections 1.9.2 and 5.7)
- includes links to the 2020 TAPR templates and discusses the context, methodology and principles applied for the development of the Queensland transmission network data (refer to Appendix B).

## CHAPTER I

# Introduction

- I.1 Introduction
- I.2 Context of the TAPR
- I.3 Purpose of the TAPR
- I.4 Role of Powerlink Queensland
- I.5 Meeting the challenges of a transitioning energy system
- I.6 Overview of approach to asset management
- I.7 Overview of planning responsibilities and processes
- I.8 Powerlink's asset planning criteria
- I.9 Powerlink's reinvestment criteria
- I.10 Stakeholder engagement



# I Introduction

## Key highlights

- The purpose of Powerlink's Transmission Annual Planning Report (TAPR) under the National Electricity Rules (NER) is to provide information about the Queensland transmission network.
- Powerlink is responsible for planning the shared transmission network within Queensland.
- Since publication of the 2019 TAPR, Powerlink has continued to proactively engage with customers and stakeholders and seek their input into Powerlink's network development objectives, network operations and investment decisions.
- Powerlink is focussed on taking an integrated approach to long-term planning in response to the challenges of transitioning to an energy system with much greater levels of variable renewable energy (VRE) generation.
- The 2020 TAPR identifies key areas of the transmission network in Queensland forecast to require expenditure in the 10-year outlook period and considers matters relevant to the Queensland transmission network highlighted in the Australian Energy Market Operator (AEMO)'s 2020 Integrated System Plan (ISP).
- Based on Powerlink's most recent planning review and information currently available, the 2020 TAPR also provides substantial detailed technical data (TAPR templates), available on Powerlink's website, to further inform stakeholders on potential transmission network developments.

## I.1 Introduction

Powerlink Queensland is a Transmission Network Service Provider (TNSP) in the National Electricity Market (NEM) and owns, develops, operates and maintains Queensland's high voltage (HV) transmission network. It has also been appointed by the Queensland Government as the Jurisdictional Planning Body (JPB) responsible for transmission network planning for the national grid within the State.

As part of its planning responsibilities, Powerlink undertakes an annual planning review in accordance with the requirements of the NER and publishes the findings of this review in its TAPR and TAPR templates.

This 2020 TAPR includes information on electricity energy and demand forecasts, the existing electricity supply system, including committed generation and transmission network reinvestments and developments, and forecasts of network capability. Risks arising from the condition and performance of existing assets, as well as emerging limitations in the capability of the network, are identified and possible solutions to address these are discussed. Interested parties are encouraged to provide input to identify the most economic solution (including non-network solutions provided by others) that satisfies the required reliability standard for customers into the future. As in previous years, and through the information and context provided, the 2020 TAPR continues to support the connection of VRE generation to Powerlink's transmission network, enabling the transition to a low carbon future.

Powerlink's annual planning review and TAPR play an important role helping to ensure the transmission network continues to meet the needs of Queensland electricity customers and participants in the NEM into the future.

## I.2 Context of the TAPR

All bodies with jurisdictional planning responsibilities in the NEM are required to undertake the annual planning review and reporting process prescribed in the NER<sup>1</sup>.

Information from this process is also provided to AEMO to assist in the preparation of its ISP which focuses on managing Australia's transition to a renewables-based energy system. The ISP integrates generation and grid development outlooks and incorporates components of the superseded National Transmission Network Development Plan (NTNDP).

---

<sup>1</sup> For the purposes of Powerlink's 2020 TAPR, Version 149 of the NER in place from 27 August 2020.

The ESOO is the primary document for examining electricity supply and demand issues across all regions in the NEM. The ISP attempts to identify the optimal development path over a planning horizon of at least 20 years for the strategic and long-term development of the national transmission system. The ISP identifies actionable and future projects, and informs market participants, investors, policy decision makers and customers on a range of development opportunities. For the 2020 TAPR, Powerlink has transitioned to using AEMO's demand and energy forecasts, consistent with those published for the 2020 ESOO.

The primary purpose of the TAPR is to provide information on the short-term to medium-term planning activities of TNSPs, whereas the focus of the ISP is strategic and long-term. Further, the ISP, Network Support and Control Ancillary Service (NSCAS Report), Inertia Report, System Strength Report and TAPR are intended to complement each other in informing stakeholders and promoting efficient investment decisions. In supporting this complementary approach, the current published versions of these documents and reports are considered in this TAPR and more generally in Powerlink's planning activities.

Interested parties may benefit from reviewing Powerlink's 2020 TAPR in conjunction with AEMO's 2018 EFI and the 2020 ESOO which was published in August 2020. The Final 2020 ISP was released on 30 July 2020.

### 1.3 Purpose of the TAPR

The purpose of Powerlink's TAPR under the NER is to provide information about the Queensland transmission network to those interested or involved in the NEM including AEMO, Registered Participants and interested parties. The TAPR also provides customers and stakeholders with an overview of Powerlink's planning processes and decision making on future investment.

It aims to provide information that assists to:

- identify locations that would benefit from significant electricity supply capability or demand side management (DSM) initiatives
- identify locations where major industrial loads could be connected
- identify locations where capacity for new generation developments exist (in particular VRE generation)
- understand how the electricity supply system affects customers and stakeholders needs
- understand the transmission network's capability to transfer quantities of bulk electrical energy
- provide input into the future development of the transmission network.

Readers should note this document and supporting TAPR templates are not intended to be relied upon explicitly for the evaluation of participants' investment decisions.

### 1.4 Role of Powerlink Queensland

Powerlink has been nominated by the Queensland Government as the entity with transmission network planning responsibility in Queensland, known as the JPB as outlined in Clause 5.22.14 of the NER.

As the owner and operator of the transmission network in Queensland, Powerlink is registered with AEMO as a TNSP under the NER. In this role, and in the context of this TAPR, Powerlink's transmission network planning and development responsibilities include:

- ensuring the network is able to operate with sufficient capability and if necessary, is augmented to provide network services to customers in accordance with Powerlink's Transmission Authority and associated reliability standard
- ensuring the risks arising from the condition and performance of existing assets are appropriately managed

# I Introduction

- ensuring the network complies with technical and reliability standards contained in the NER and jurisdictional instruments including the requirement to maintain minimum fault levels as prescribed by AEMO
- conducting annual planning reviews with Distribution Network Service Providers (DNSPs) and other TNSPs whose networks are connected to Powerlink's transmission network, that is Energex and Ergon Energy (part of the Energy Queensland Group), Essential Energy and TransGrid
- advising AEMO, Registered Participants and interested parties of asset reinvestment needs within the time required for action
- advising AEMO, Registered Participants and interested parties of emerging network limitations within the time required for action
- developing recommendations to address emerging network limitations or the need to address the risks arising from ageing network assets remaining in-service through joint planning with DNSPs and TNSPs, and consultation with AEMO, Registered Participants and interested parties, with potential solutions including network upgrades or non-network options such as local generation and DSM initiatives
- examining options and developing recommendations to address transmission constraints and economic limitations across interconnectors through joint planning with other TNSPs and Network Service Providers (NSP), and consultation with AEMO, Registered Participants and interested parties
- assessing whether a proposed transmission network augmentation has a material impact on networks owned by other TNSPs, and in assessing this impact Powerlink must have regard to the objective set of criteria published by AEMO in accordance with Clause 5.21 of the NER
- undertaking the role of the proponent for regulated transmission augmentations and the replacement of transmission network assets in Queensland.

In addition, Powerlink participates in inter-regional system tests associated with new or augmented interconnections.

## 1.5 Meeting the challenges of a transitioning energy system

Powerlink is focussed on taking an integrated approach to long-term planning, including the development of suitable Renewable Energy Zones (REZ) in Queensland and associated network reinforcement.

Powerlink continues to adapt and respond to the current challenges of a rapidly changing operating environment which is transitioning to an electricity system with much greater levels of VRE generation. Broadly these challenges include:

- system strength (refer to Chapters 3, 5, 6 and 8)
- network congestion on the transmission network as generation patterns change (refer to Chapters 5, 6 and 7)
- Marginal Loss factors (MLF) (refer to Chapter 8)
- minimum demand (refer to Chapters 2, 3, 5, 6 and 7)

To ensure positive outcomes for customers, Powerlink is responding to these challenges holistically in undertaking long-term network planning to ensure the optimal performance and utilisation of the transmission network in Queensland.

As well as responding safely to the ongoing impacts of the COVID-19 pandemic in 2020 while maintaining reliability of supply, Powerlink is also continuing to:

- undertake ongoing active customer and stakeholder engagement for informed decision making and planning
- implement and adopt the recommendations of various reviews
- adapt to changes in customer behaviour and economic outlook
- ensure its approach to investment decisions delivers positive outcomes for customers
- place considerable emphasis on an integrated, flexible and holistic analysis of future investment needs

- support diverse generation connections
- ensure compliance with changes in legislation, regulations and operating standards
- focus on developing options that deliver a secure, safe, reliable and cost effective transmission network.

## 1.6 Overview of approach to asset management

Powerlink's asset management system captures significant internal and external drivers on the business and sets out initiatives to be adopted. The Asset Management Policy forms the foundation of the Asset Management Strategy. Information on the principles and approach set out in these documents which guide Powerlink's analysis of future network investment needs and key investment drivers is provided in Chapter 4.

## 1.7 Overview of planning responsibilities and processes

### 1.7.1 Planning criteria and processes

Powerlink has obligations that govern how it should address forecast network limitations. These obligations are prescribed by *Queensland's Electricity Act 1994 (the Act)*, the NER and Powerlink's Transmission Authority.

The Act requires that Powerlink 'ensure as far as technically and economically practicable, that the transmission grid is operated with enough capacity (and if necessary, augmented or extended to provide enough capacity) to provide network services to persons authorised to connect to the grid or take electricity from the grid'.

It is a condition of Powerlink's Transmission Authority that it meets licence and NER requirements relating to technical performance standards during intact and contingency conditions. The NER sets out minimum performance requirements of the network and connections, and requires that reliability standards at each connection point be included in the relevant connection agreement.

New network developments and reinvestments are proposed to meet these legislative and NER obligations. Powerlink may also propose transmission investments that deliver a net market benefit when assessed in accordance with the Regulatory Investment Test for Transmission (RIT-T). The requirements for initiating solutions to meet forecast network limitations or the need to address the risks arising from ageing network assets remaining in-service, including new regulated network developments or non-network solutions, are set down in Clauses 5.14.1, 5.16.4, 5.16A, 5.20B, 5.20C and 5.22.14 of the NER.

While each of these clauses prescribes a slightly different process, at a higher level the main steps in network planning for transmission investments subject to the RIT-T can be summarised as follows:

- Publication of information regarding the nature of network limitations, the risks related to ageing network assets remaining in-service and the need for action which includes an examination of demand growth and its forecast exceedance of the network capability (where relevant).
- Consideration of generation and network capability to determine when additional capability is required.

Consultation on assumptions made and credible options, which may include:

- network augmentation
- asset replacement
- asset retirement
- network reconfiguration and/or local generation or DSM initiatives
- together with classes of market benefits considered to be material which should be taken into account in the comparison of options

# I Introduction

- analysis and assessment of credible options, which include costs, market benefits, material inter-network impact and material impact on network users<sup>2</sup> (where relevant)
- identification of the preferred option that satisfies the RIT-T, which maximises the present value of the net economic benefit to all those who produce, consume and transport electricity in the market
- consultation and publication of a recommended course of action to address the identified future network limitation or the risks arising from ageing network assets remaining in-service.

## 1.7.2 Integrated planning of the shared network

Powerlink is responsible for planning the shared transmission network within Queensland, and inter-regionally. The NER sets out the planning process and requires Powerlink to apply the RIT-T to transmission investment proposals for augmentations to the transmission network and the replacement of network assets over \$6 million. Powerlink continues to publish information and consult with potential providers of non-network solutions for the provision of system strength and inertia network services as notified by AEMO. Planning processes require consultation with AEMO, Registered Participants and interested parties, including customers, generators, DNSPs and other TNSPs. Section 5.6 discusses current consultations, as well as anticipated future consultations, that will be conducted in line with the relevant processes prescribed in the NER.

Significant inputs to the network planning process are the:

- forecast of customer electricity demand (including DSM) and its location
- location, capacity and arrangement of existing, new and retiring generation (including embedded generation)
- condition and performance of assets and an assessment of the risks arising from ageing network assets remaining in-service
- assessment of future network capacity to meet the required planning criteria and efficient market outcomes, including limiting transmission losses to the extent possible, system strength and the potential to facilitate future storage requirements to help address minimum demand.

The 10-year forecasts of electrical demand and energy across Queensland are used, together with forecast generation patterns, to determine potential flows on transmission network elements. The location and capacity of existing and committed generation in Queensland is sourced from AEMO, unless modified following advice from relevant participants and is provided in tables 6.1 and 6.2. Information about existing and committed embedded generation and demand management within distribution networks is provided by DNSPs and AEMO.

Powerlink examines the capability of its existing network and the future capability following any changes resulting from:

- committed network projects (for both augmentation and to address the risks arising from ageing network assets remaining in-service)
- the impact of coal-fired generation retirements on transmission network power flows
- existing and future renewable developments including REZ
- anomalies in Powerlink's operating environment or changes in technical characteristics such as minimum demand and system strength as the power system continues to evolve.

This includes consultation with the relevant DNSP in situations where the performance of the transmission network may be affected by the distribution network, for example where the two networks operate in parallel.

Where potential flows could exceed network capability, Powerlink notifies market participants of these forecast emerging network limitations. If the capability violation exceeds the required reliability standard, joint planning investigations are carried out with DNSPs (or other TNSPs if relevant) in accordance with Clause 5.14.1 of the NER. The objective of this joint planning is to identify the most cost effective solution, regardless of asset boundaries, including potential non-network solutions (refer to Chapter 3).

---

<sup>2</sup> NER Clause 5.16.3 (a) (5).

Powerlink must maintain its current network so that the risks arising from the condition and performance of existing assets are appropriately managed. Powerlink undertakes a program of asset condition assessments to identify emerging asset condition related risks.

As assets approach the end of their technical service life, Powerlink examines a range of options to determine the most appropriate reinvestment strategy, applying a flexible and integrated approach which takes into account multiple factors. Consideration is given to optimising the topography and capacity of the network, taking into account current and future network needs, including future renewable generation.

In many cases, power system flows and patterns have changed over time. As a result, the ongoing network capacity requirements need to be re-evaluated. Individual asset reinvestment decisions are not made in isolation, and reinvestment in assets is not necessarily undertaken on a like-for-like basis. Rather, asset reinvestment strategies and decisions are made taking into account enduring need, the inter-related connectivity and characteristics of the high voltage (HV) system, and are considered across an area or transmission corridor. The consideration of potential non-network solutions forms an important part of this flexible and integrated planning approach.

The integration of condition and demand based limitations delivers cost effective solutions that address both reliability of supply and risks arising from assets approaching end of technical service life.

Powerlink considers a range of strategies and options to address emerging asset related condition and performance issues. These strategies include:

- retiring or decommissioning assets where there is unlikely to be an ongoing future need
- reinvesting to extend the service life of assets
- replacing assets of different capacity or type
- changing the topography of the network
- implementing non-network solutions.

Each of these options is considered in the context of future capacity. In accordance with the NER, information regarding proposed transmission reinvestments within the 10-year outlook period must be published in the TAPR and TAPR templates. More broadly, this provides information to the NEM, including AEMO, Registered Participants and interested parties (including non-network providers) on Powerlink's planning processes, anticipated public consultations, and decision making relating to potential future reinvestments. Further information is provided in Section 5.7 and Appendix B.

A summary of Powerlink's integrated planning approach that takes into account both network capacity needs and end of technical service life related issues is presented in Figure I.1.

# I Introduction

Figure I.1 Overview of Powerlink's TAPR planning process

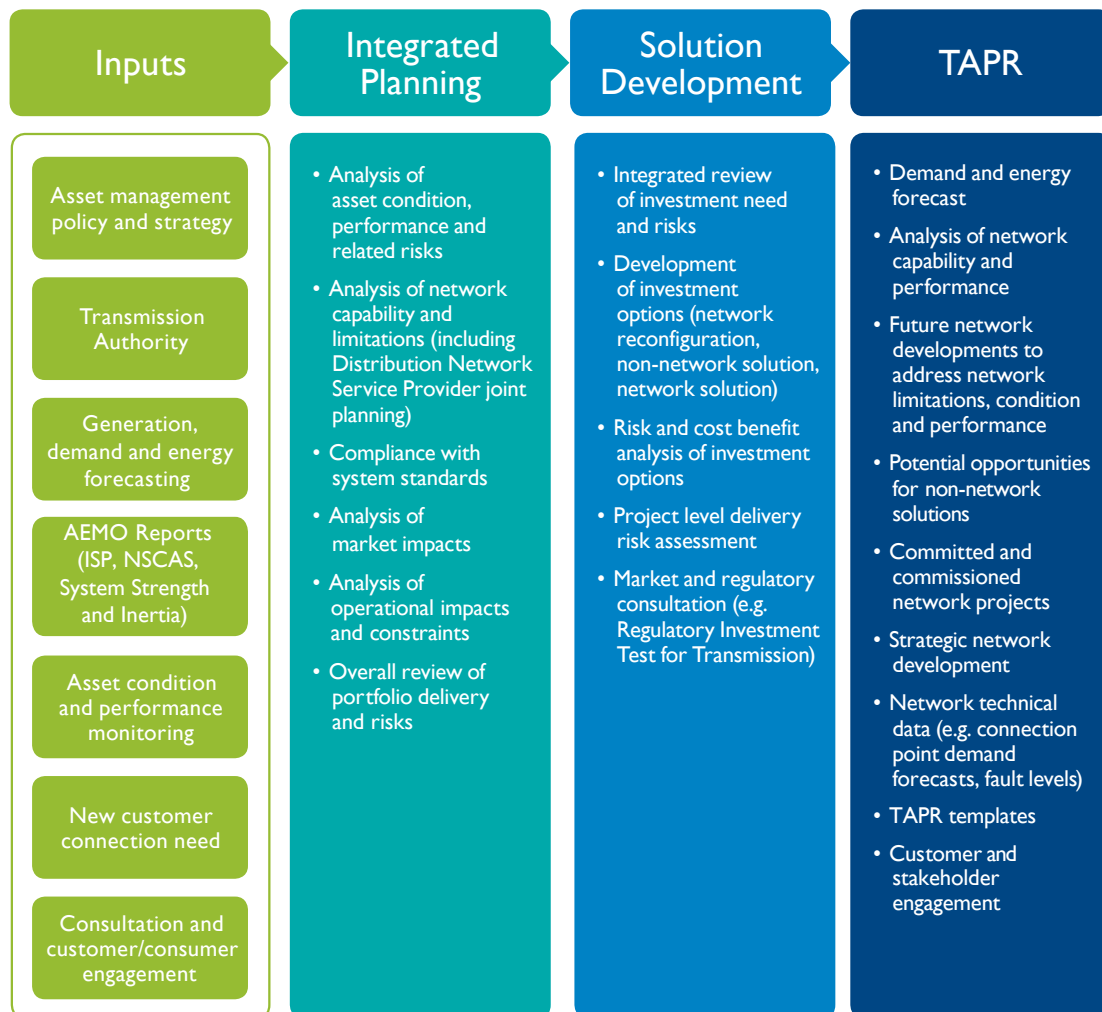

## 1.7.3 Joint planning

Powerlink undertakes joint planning with other NSPs to collaboratively identify network and non-network solutions, which best serve the long-term interests of customers, irrespective of the asset boundaries. This process provides a mechanism for providers to discuss and identify technically feasible network and non-network options that provide lowest cost solutions across the network as a whole, regardless of asset ownership or jurisdictional boundaries.

Powerlink's joint planning, while traditionally focussed on the DNSPs (Energex, Ergon Energy and Essential Energy) and TransGrid, also includes consultation with AEMO, other Registered Participants, load aggregators and other interested parties.

Joint planning with AEMO is critical to ensure the best possible jurisdictional inputs are provided to the ISP process in the long-term interests of customers. These inputs include condition drivers for significant intra-regional infrastructure, possible development options and cost of options that increase capacity of critical intra and inter-regional grid sections, together with the associated capacity improvement.

Also, Powerlink undertakes joint planning with AEMO to periodically assess the minimum fault level and system strength requirements for the Queensland jurisdiction. A review undertaken in April 2020 concluded that there was an immediate fault level shortfall at the Ross fault level node in Queensland. As the Queensland TNSP and JPB, Powerlink is the system strength service provider and is responsible for meeting this identified shortfall. Further information is provided in sections 5.7.1. and 8.4.

Information on Powerlink's joint planning framework, and the joint planning activities that Powerlink has undertaken with other NSPs and AEMO since publication of the 2019 TAPR is provided in Chapter 3.

#### 1.7.4 Connections

Participants wishing to connect to the Queensland transmission network include new and existing generators, major loads and other NSPs. New connections or alterations to existing connections involves consultation between Powerlink and the connecting party to negotiate a Connection and Access Agreement (CAA). Negotiation of the CAA requires the specification and then compliance by the generator or load to the required technical standards. The process of agreeing to technical standards also involves AEMO. The services provided can be prescribed for DNSPs (regulated), negotiated or non-regulated services in accordance with the definitions in the NER or the framework for provision of such services.

From July 2018 new categories of connection assets were defined, namely Identified User Shared Assets (IUSA) and Dedicated Connection Assets (DCA). All new DCA services, including design, construction, ownership and operation and maintenance are non-regulated services. IUSA assets with capital costs less than \$10 million are negotiated services that can only be provided by Powerlink. IUSA assets with capital costs above \$10 million are non-regulated services. Powerlink remains accountable for operation of all IUSAs and any above \$10 million must enter into a Network Operating Agreement to provide operations and maintenance services. Further information in relation to the connection process is available on Powerlink's website (refer to Chapter 8).

#### 1.7.5 Interconnectors

As outlined in Section 1.2, the purpose of the ISP is to establish a strategic whole of system plan for a 20-year planning horizon for efficient power system development in the long-term interests of customers. The ISP also serves the regulatory purpose of identifying actionable projects to meet power system needs. These projects may relate to the potential development of new interconnectors or expanding the capacity of existing interconnectors. For actionable projects the responsible TNSPs are required to undertake a Regulatory Investment Test for Transmission (RIT-T) and publish a Project Assessment Draft Report (PADR) by a specified date. Under the NER, TNSPs also retain the ability to conduct RIT-Ts outside the ISP framework.

Information on the preliminary activities required for the potential interconnector upgrade and/or new interconnectors is provided in Chapter 7. This includes details in relation to the future RIT-T to be undertaken by TransGrid and Powerlink to consider further expanding New South Wales (NSW)-Queensland transmission transfer capacity as identified in the 2020 ISP as a future ISP project.

### 1.8 Powerlink's asset planning criteria

The Queensland Government amended Powerlink's N-1 criterion in 2014 to allow for increased flexibility. The planning standard permits Powerlink to plan and develop the transmission network on the basis that load may be interrupted during a single network contingency event. The following limits are placed on the maximum load and energy that may be at risk of not being supplied during a critical contingency:

- will not exceed 50MW at any one time
- will not be more than 600MWh in aggregate.

The risk limits can be varied by:

- a connection or other agreement made by the transmission entity with a person who receives or wishes to receive transmission services, in relation to those services or
- agreement with the Queensland Energy Regulator (QER).



# I Introduction

Powerlink is required to implement appropriate network or non-network solutions in circumstances where the limits set out above are exceeded or when the economic cost of load at risk of not being supplied justifies the cost of the investment. Therefore, the planning standard has the effect of deferring or reducing the extent of investment in network or non-network solutions required. Powerlink will continue to maintain and operate its transmission network to maximise reliability to customers.

As mentioned, Powerlink's transmission network planning and development responsibilities include developing recommendations to address emerging network limitations, or the need to address the risks arising from ageing network assets remaining in-service, through joint planning (refer to Section 1.7.3).

Energex and Ergon Energy were issued amended Distribution Authorities from July 2014. The service levels defined in their respective Distribution Authority differ to that of Powerlink's authority. Joint planning accommodates these different planning standards by applying the planning standard consistently with the owner of the asset which places load at risk during a contingency event.

Powerlink has established policy frameworks and methodologies to support the implementation of this standard. These are being applied in various parts of the Powerlink network where possible emerging limitations are being monitored. For example, based on AEMO's Central scenario forecast discussed Chapter 2, voltage stability limitations occur in the Proserpine area within the outlook period. However, the load at risk of not being supplied during a contingency event does not exceed the risk limits of the planning standard. In this instance the planning standard is deferring investment and delivering savings to customers.

The planning standard will deliver further opportunities to defer investment if new mining, metal processing or other industrial loads develop (discussed in Table 2.1 of Chapter 2). These new loads are within the resource rich areas of Queensland or at the associated coastal port facilities but have not yet reached the development status necessary to be included (either wholly or in part) in AEMO's 2020 ES00 Central scenario. The loads have the potential to significantly impact the performance of the transmission network supplying, and within, these areas. The possible impact of these loads is discussed in Section 7.3. The planning standard may not only affect the timing of required investment but also in some cases affords the opportunity for incremental solutions that would not have otherwise met the original N-1 criterion.

## 1.9 Powerlink's reinvestment criteria

Powerlink is committed to ensuring the sustainable long-term performance of its assets to deliver safe, reliable and cost effective transmission services to customers, stakeholders and communities across Queensland. Powerlink demonstrates this by adopting a proactive approach to asset management that optimises whole of lifecycle costs, benefits and risks, while ensuring compliance with applicable legislation, regulations, standards, statutory requirements, and other relevant instruments.

The reinvestment criteria framework defines the methodology that Powerlink uses to assess the need and timing for intervention on network assets to ensure that industry compliance obligations are met. The methodology aims to improve transparency and consistency within the asset reinvestment process, enabling Powerlink's customers and stakeholders to better understand the criteria to determine the need and timing for asset intervention.

The reinvestment criteria framework is relevant where the asset condition changes so it no longer meets its level of service or complies with a regulatory requirement. This category of reinvestment is triggered when the existing asset has degraded over time and no longer provides the required standard of service as prescribed within applicable legislation, regulations and standards.

The trigger to intervene needs to be identified early enough to provide an appropriate lead time for the asset reinvestment planning and assessment process. The need and timing for intervention is defined when business as usual activities (including routine inspections, minor condition based and corrective maintenance and operational refurbishment projects) no longer enable the network asset to meet prescribed standards of service due to deteriorated asset condition.

Powerlink’s asset reinvestment process (refer to Figure 1.2) enables timely, informed and prudent investment decisions to be made that consider all economic and technically feasible options including non-network alternatives or opportunities to remove assets where they are no longer required. An assessment of the need and timing for intervention is the first stage of this process.

**Figure 1.2 – Asset Reinvestment Process**

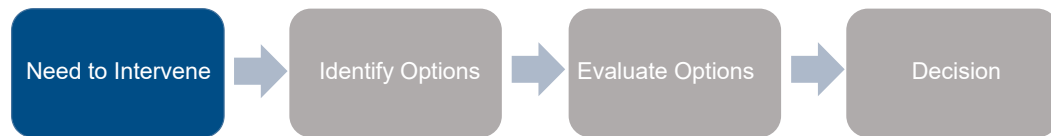

## 1.10 Stakeholder engagement

Powerlink shares effective, timely and transparent information with its customers and stakeholders using a range of engagement methods. Customers are defined as those who are directly connected to Powerlink’s network and electricity consumers, such as households and businesses, who are supplied via the distribution network. There are also stakeholders who can provide Powerlink with non-network solutions. These stakeholders may either connect directly to Powerlink’s network, or connect to the distribution networks. As an example, during April/May 2020 Powerlink participated in a large number of informal discussions with potential non-network solution providers in relation to the Expression of interest (EOI) for system strength services in Queensland to address the fault level shortfall at Ross. This process assisted in providing clarification and support to providers prior to the lodgement of formal submissions.

The TAPR is just one avenue that Powerlink uses to communicate information about transmission planning in the NEM. Through the TAPR, Powerlink aims to increase stakeholder and customer understanding and awareness of our business practices, including load forecasting and transmission network planning.

### 1.10.1 Customer and stakeholder engagement

Powerlink is committed to proactively engaging with stakeholders and customers and seeking their input into Powerlink’s business processes and decision-making. All engagement activities are undertaken in accordance with our Stakeholder Engagement Framework which sets out the principles, objectives and outcomes Powerlink seeks to achieve in our interactions. A number of key performance indicators are used to monitor progress towards achieving Powerlink’s stakeholder engagement performance goals. In particular, Powerlink undertakes a comprehensive bi-ennial stakeholder survey to gain insights about stakeholder perceptions of Powerlink, its social licence to operate and reputation. Most recently completed as a ‘pulse check’ survey in November 2019, it provides comparisons between baseline research undertaken in 2012 and year-on-year trends to inform engagement strategies with individual stakeholders. The latest survey also sought specific insights from existing directly-connected customers and renewable proponents on aspects of customer service and delivery, and Powerlink’s responsiveness.

#### *2019/20 Stakeholder engagement activities*

Since the publication of the 2018 TAPR, Powerlink has engaged with stakeholders and customers in various ways through a range of forums as outlined below.

#### *Transmission Network Forum*

In September 2019, more than 100 customer, community advocacy group, government and industry representatives attended Powerlink’s annual Transmission Network Forum. The forum provided updates on the state of the network and 2019 TAPR highlights, followed by interactive breakout sessions on using non-network solutions to reduce short-term demand peaks and managing renewable connections in the transmission network of the future.

# I Introduction

The 2020 Transmission Network Forum was held in an online format in early September to seek customer and stakeholder input on longer term power system planning and the challenges of the energy transition. A key focus of discussion at the 2020 forum was also focussed on the Queensland Government announcement in early September of \$500 million in funding to support REZ development, in addition to \$145 million previously announced for REZ support. Stakeholders and customers support Powerlink continuing to work closely with Government in relation to allocation of this funding, which will play a key role in driving economic recovery post the COVID-19 pandemic.

## ***Customer Panel***

Powerlink hosts a Customer Panel that provides an interactive forum for our stakeholders and customers to give input and feedback to Powerlink regarding our decision making, processes and methodologies. Comprised of members from a range of sectors including industry associations, resources, community advocacy groups, directly connected customers and distribution representatives, the panel provides an important avenue to keep our stakeholders better informed about operational and strategic topics of relevance. The panel met in July and February 2020, and December, August and June 2019. Key topics for discussion included the upcoming Revenue Determination process, transmission pricing consultation and Powerlink's first Energy Charter Disclosure Statement to customers and stakeholders. The panel was also engaged to provide input on the asset reinvestment criteria outlined earlier in this chapter, which enabled Powerlink to refine the criteria with customer input.

## ***2020 TAPR webinar***

Powerlink intends to host a webinar in late 2020 to share the TAPR's highlights and key updates with customers and stakeholders.

## ***Stakeholder engagement for RIT-Ts***

Powerlink recognises the importance of transparency for stakeholders and customers, particularly when undertaking transmission network planning and engaging in public consultation under the RIT-T process.

In relation to engagement activities for RIT-Ts, Powerlink is committed to a balanced approach in the public consultation process as determined with its Customer Panel. In addition, Powerlink will utilise and be guided by the Australian Energy Regulator (AER)'s Stakeholder Engagement Framework and Consumer Engagement Guideline for Network Service Providers as the benchmarks when consulting as part of the RIT-T process.

Taking this into account, the appropriate level of engagement for RIT-Ts may most easily be identified through feedback received from stakeholders on proposed investments identified in the TAPR, discussion and consideration of the context of the proposed investment. Engagement activities for RIT-Ts are assessed on a case-by-case basis. This includes consideration of the:

- potential impacts on stakeholders
- opportunities for network reconfiguration or asset retirement
- estimated capital cost
- type of RIT-T process being undertaken (refer to Section 5.6.1).

Detailed information on proposed engagement activities for RIT-Ts can be found on Powerlink's website.

Powerlink and TransGrid held a joint webinar in October 2019 to share the findings contained in the PADR, Expanding NSW-Queensland Transmission Transfer Capacity 'minor' Group 1 2018 ISP actionable project, as the second stage of the RIT-T process. The webinar provided an opportunity outside of the formal consultation process to engage with and respond to questions from a wide range of stakeholders including consumer advocates, customer representatives, and market participants. This RIT-T has since been completed (refer to Section 5.7.14).

It is anticipated that the provision and exchange of early information through engagement activities will generate more opportunities for interactions with our customers and stakeholders, during formal or informal consultation processes.

More information on Powerlink's engagement activities is available on our website.

### 1.10.2 Non-network solutions

Powerlink has established processes for engaging with stakeholders for the provision of non-network services in accordance with the requirements of the NER. These engagement processes centre on publishing relevant information on the need and scope of viable non-network solutions to emerging network limitations and more recently, in relation to the replacement of network assets. For a given network limitation or potential asset replacement, the viability and an indicative specification of non-network solutions are first introduced in the TAPR and more recently, in TAPR templates. As the identified need date approaches and a detailed planning analysis is undertaken, further opportunities are explored in the consultation and stakeholder engagement processes undertaken as part of any subsequent RIT-T.

In the past, these processes have been successful in delivering non-network solutions to emerging network limitations. As early as 2002, Powerlink engaged generation units in North Queensland (NQ) to maintain reliability of supply and defer transmission projects between central and northern Queensland. Powerlink also entered into network support services as part of the solution to address emerging limitations in the Bowen Basin area, ending these in 2016.

Non-network solutions such as DSM will be essential in future years to avoid or delay the need to augment the transmission network in response to any increase in maximum demand.

Powerlink is committed to the ongoing development of its non-network engagement processes to facilitate the identification of optimal non-network solutions:

- to address future network limitations or address the risks arising from ageing assets remaining in-service within the transmission network
- more broadly, in combination with network developments as part of an integrated solution to complement an overall network reconfiguration strategy
- to address voltage instability, inertia and system strength requirements, ensuring the secure operation of the transmission network
- to provide demand management and load balancing.

Powerlink's 2020 TAPR includes a compendium for non-network providers that highlights possible future non-network opportunities in key areas of the transmission network in Queensland forecast to require expenditure in the next five years (refer to Appendix F). In addition, the TAPR templates published in conjunction with the 2020 TAPR provide detailed technical data on Powerlink's transmission connection points and line segments. This data may be of value to non-network providers when considering opportunities for the development of potential non-network solutions (refer to Appendix B). Powerlink will continue to engage and work collaboratively with non-network providers during the RIT-T or other consultation processes to arrive at the optimal solution for customers.

Powerlink will continue to hold webinars on an ongoing basis as relevant and topical issues arise that are likely to be of interest to non-network providers and other stakeholders. In addition to enabling the delivery of information and providing a discussion platform, other benefits provided through informal activities, such as webinars, include a broadening of communication channels to reach a wider audience and as an aid to fostering positive relationships with non-network providers.

Since publication of the 2019 TAPR, Powerlink has continued its collaboration with Energy Networks Australia (ENA) and the Institute for Sustainable Futures<sup>3</sup> regarding the Network Opportunity Mapping project. This project aims to provide enhanced information to market participants on network constraints and the opportunities for demand side solutions. These collaborations further demonstrate Powerlink's commitment to using a variety of platforms to broaden stakeholder awareness regarding possible commercial opportunities for non-network solutions.

---

<sup>3</sup> Information available at [Network Opportunity Mapping](#).

## *Non-network Engagement Stakeholder Register*

Powerlink has a Non-network Engagement Stakeholder Register (NNESR) to inform non-network providers of the details of emerging network limitations and other future transmission network needs, such as the replacement of network assets, which may have the potential for non-network solutions. The NNESR is comprised of a variety of interested stakeholders who have the potential to offer network support through advancement in technologies, existing and/or new generation or DSM initiatives (either as individual providers or aggregators).

Potential non-network providers are encouraged to register their interest in writing to [networkassessments@powerlink.com.au](mailto:networkassessments@powerlink.com.au) to become a member of Powerlink's NNESR.

### **1.10.3 Focus on continuous improvement**

As part of Powerlink's commitment to continuous improvement, the 2020 TAPR focuses on an integrated approach to future network development and contains detailed discussion on key areas of the transmission network forecast to require expenditure.

In conjunction with condition assessments and risk identification, as assets approach their anticipated replacement dates, possible reinvestment alternatives undergo detailed planning studies to confirm alignment with future reinvestment, optimisation and delivery strategies. These studies have the potential to deliver new information and may provide Powerlink with an opportunity to:

- improve and further refine options under consideration
- consider other options from those originally identified, delivering positive outcomes for customers.

Information regarding possible reinvestment alternatives is updated annually within the TAPR and includes discussion on the latest information available as planning studies mature.

The 2020 TAPR:

- discusses emerging challenges as the network transitions to much greater levels of VRE generation (refer to Chapters 2, 5 and 7)
- provides information in relation to joint planning and Powerlink's approach to asset management (refer to Chapters 3 and 4)
- discusses possible future network asset investments for the 10-year outlook period (refer to Chapter 5)
- includes the most recent information for the proposed replacement of network assets which are anticipated to be subject to the RIT-T in the next five years (refer to Chapter 5)
- discusses the potential for generation developments (in particular VRE generation) and the challenges related to the management of system strength (refer to Chapter 8)
- contains a quick reference guide on where to locate information on potential non-network opportunities in the TAPR, grouped by investment type (refer to Appendix F) and discusses Powerlink's approach to assisting the development of non-network solutions – specifically, through the ongoing improvement of engagement practices for non-network solution providers and provision of information (refer to sections 1.9.2 and 5.7)
- includes links to the 2020 TAPR templates and discusses the context, methodology and principles applied for the development of the Queensland transmission network data (refer to Appendix B).

## **CHAPTER 2**

# Energy and demand projections

- 2.1 Overview
- 2.2 Customer consultation
- 2.3 Demand forecast outlook
- 2.4 Zone forecasts
- 2.5 Summer and winter minimum and maximum daily profiles
- 2.6 Annual load duration curves

## 2 Energy and demand projections

### Key highlights

- This chapter describes the historical energy and demand, and provides forecast data separated by zone.
- The 2019/20 summer maximum transmission delivered demand of 8,766MW occurred at 6:00pm on 3 February 2020, was 203MW lower than the record demand set in 2018/19.
- The 2019/20 summer in Queensland had above average daily maximum and minimum temperatures, particularly in the earlier summer months, which saw a new monthly maximum delivered demand for the month of January 2020.
- The 2020 Queensland minimum transmission delivered demand of 3,003MW occurred at 12.30pm on 27 September 2020, setting a record minimum transmission delivered demand.
- Native plus rooftop photovoltaic (PV) energy reduced by approximately 2.2% between 2019 and 2020.
- Powerlink has adopted AEMO's 2020 Electricity Statement of Opportunity (ESOO) forecasts in its planning analysis for the 2020 Transmission Annual Planning Report (TAPR). Powerlink is focussed on working with Australian Energy Market Operator (AEMO) to understand the potential future impacts of emerging technologies so transmission network services are developed in ways that are valued by customers.
- Reductions in Queensland transmission delivered demand and energy from the COVID-19 pandemic are accounted for in the 2020 TAPR forecast.
- Based on AEMO's Central scenario Queensland's delivered maximum demand is expected to maintain low growth with an average annual increase of 0.7% per annum over the next 10 years.
- The uptake of rooftop PV and distribution connected solar systems is further reducing delivered demand during the day to the point where this is now lower than night time light load conditions. The rate at which minimum demand declines over the coming years will be closely related to the rate at which rooftop PV systems are installed. Falling minimum demand will result in a variety of impacts on the power system, some of which may necessitate investment on the transmission system.
- Queensland's transmission delivered energy is expected to decline over the next 10 years predominantly due to continued installation of variable renewable generation embedded within distribution networks and continuing installations of rooftop PV. Based on AEMO's Central scenario, transmission delivered energy consumption is expected to decline at an average rate of 0.7% per annum over the next 10 years.

### 2.1 Overview

The 2019/20 summer Queensland maximum delivered demand occurred at 6:00pm on 3 February 2020, when 8,766MW was delivered from the transmission grid (refer to Figure 2.6 for load measurement definitions). Operational 'as generated' and native demand peaks were recorded 30 minutes earlier at 5:30pm on 3 February 2020, with operational 'as generated' reaching 9,853MW, native demand reaching 9,268MW and transmission delivered demand reducing to 8,710MW. After weather correction, the 2019/20 summer maximum transmission delivered demand was 8,605MW, 0.2% higher than the 2019 TAPR forecast.

Figure 2.1 shows observed temperatures for Brisbane during summer 2019/20 compared with long-term averages, revealing a slightly warmer summer than average in south east Queensland, with daily maximum temperatures subdued in February and March.

Figure 2.1 Brisbane temperature ranges over summer 2019/20 (1)

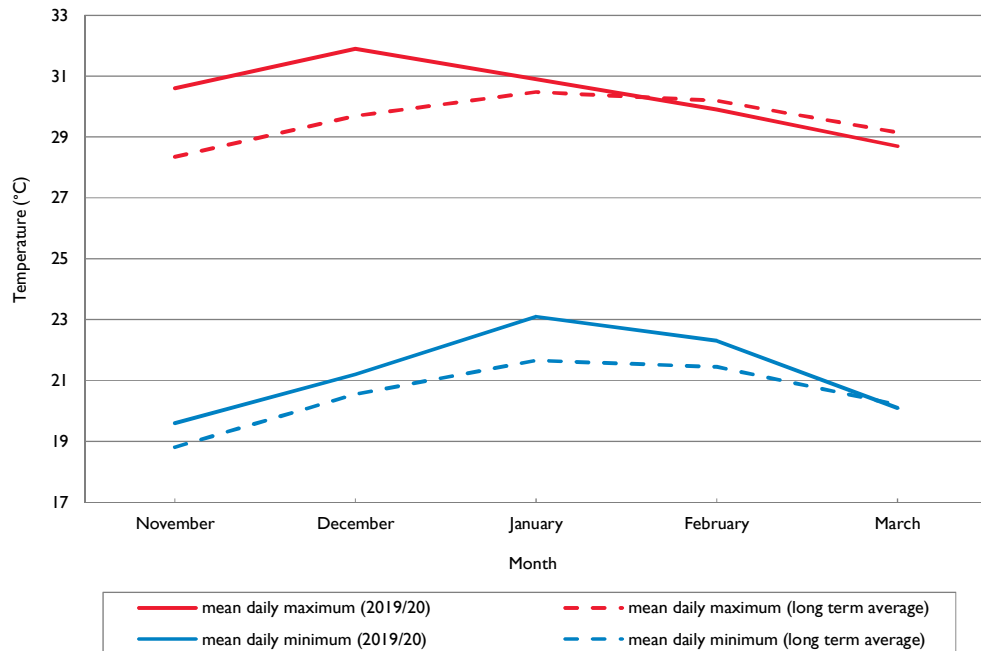

Note:

(1) Long-term average based on years 2000 to 2020.

The 2020 Queensland minimum delivered demand occurred at 12:30pm on 27 September 2020, when only 3,003MW was delivered from the transmission grid (refer to Figure 2.6 for load measurement definitions). Operational 'as generated' minimum demand was recorded 30 minutes earlier at 12:00pm dropping to 3,860MW. Direct connect loads made up about two-thirds of the demand with Distribution Network Service Provider (DNSP) customers only making up one-third. Mild weather conditions, during a weekend (Sunday) in combination with strong contribution from rooftop PV were contributors to this record minimum demand. This minimum demand corresponds to the winter 2022 90% PoE minimum delivered demand under the Central scenario. Powerlink will work with AEMO to better understand underlying drivers and conditions to inform future forecasts.

Energy delivered from the transmission network for 2019/20 at 47,860GWh was within 2% of the 2019 TAPR forecast of 48,736GWh. Weather conditions and COVID-19 pandemic impacts contribute to the difference. Figure 2.2 illustrates monthly difference in native plus rooftop PV energy consumption between 2020 and 2019 since COVID-19 restrictions commenced in March. Queensland's native plus rooftop PV energy consumption reduced by an average of approximately 2.2%, but as evidenced the reductions are closely correlated with milder temperature conditions.



## 2 Energy and demand projections

**Figure 2.2** 2020 and 2019 monthly native plus rooftop PV energy consumption comparison since March 2020

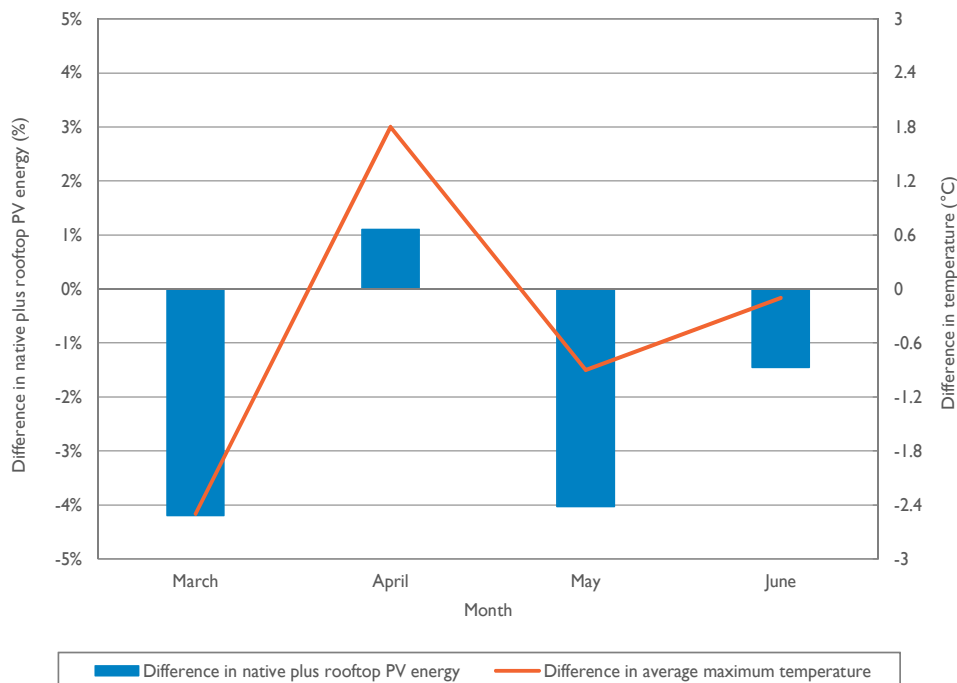

The publishing of the 2020 TAPR later in the year has allowed Powerlink to incorporate AEMO's recently published 2020 ESOO Queensland forecasts into the planning analysis for the TAPR. Powerlink has worked with AEMO to derive transmission delivered equivalent demand and energy forecasts based on the forecast operational sent out quantities used in the ESOO. Further information on the development of AEMO's 2020 ESOO is available on AEMO's website<sup>1</sup>.

The AEMO 2020 ESOO forecasts provide the top-down, whole of state maximum demand forecast for the Queensland region. These are reconciled with bottom-up forecasts from DNSPs and directly connected customers to create the granular models needed to inform zonal or more localised issues.

Powerlink is committed to understanding the future impacts of emerging technologies and to work with AEMO so that these are accounted for within the forecasts. This will allow transmission network services to be developed in ways that are valued by customers. For example, future developments in battery storage technology coupled with rooftop PV and EV could see significant changes to future electricity usage patterns. This could reduce the need to develop transmission services to cover short duration peaks.

The observed electrical load for the coal seam gas (CSG) industry experienced demand slightly above those forecast in the 2019 TAPR. The CSG demand reached a peak of 801MW in 2019/20. No new CSG loads have committed to connect to the transmission network since the publication of 2019 TAPR.

The Federal Government's large-scale renewable energy target of 33,000GWh per annum by 2020 and the Queensland Government's 50% renewable energy target by 2030 (Queensland Renewable Energy Target (QRET) has driven renewable capacity in the form of solar PV and wind farms to connect to the Queensland transmission and distribution networks (refer to Table 6.1 and Table 6.2).

Additional uncommitted distribution connected solar and wind farm capacity has been included into the 10-year outlook period from 2023 to model the Queensland Government's target of 50% renewable energy by 2030.

<sup>1</sup> AEMO, [2020 Electricity Demand Forecasting Methodology Paper](#), August 2020.

At the end of 2019/20, Queensland reached 3,285MW of installed rooftop PV capacity<sup>2</sup>. Growth in rooftop PV capacity increased from around 40MW per month in 2018/19 to 59MW per month in 2019/20. An impact of rooftop PV, has been the time shift of the state's maximum demand, which now occurs around 5:30pm. As a result of significant capacity of rooftop PV and small-scale PV non-scheduled generation (PVNSG), maximum demand is unlikely to occur in the daytime, it is now expected to occur in the early evening.

Figure 2.3 shows a comparison of Powerlink's 2019 TAPR delivered summer maximum demand forecast based on medium economic outlook with AEMO's 2020 ESOO based on the Central scenario, both with 50% Probability of Exceedance (PoE). The AEMO 2020 ESOO Central scenario factors in the expected reduction in consumption due to COVID-19 pandemic impacts extending throughout summer 2020/21.

**Figure 2.3** Comparison of the 2019 TAPR medium economic outlook demand forecast with AEMO's 2020 ESOO Central scenario (1)(2)

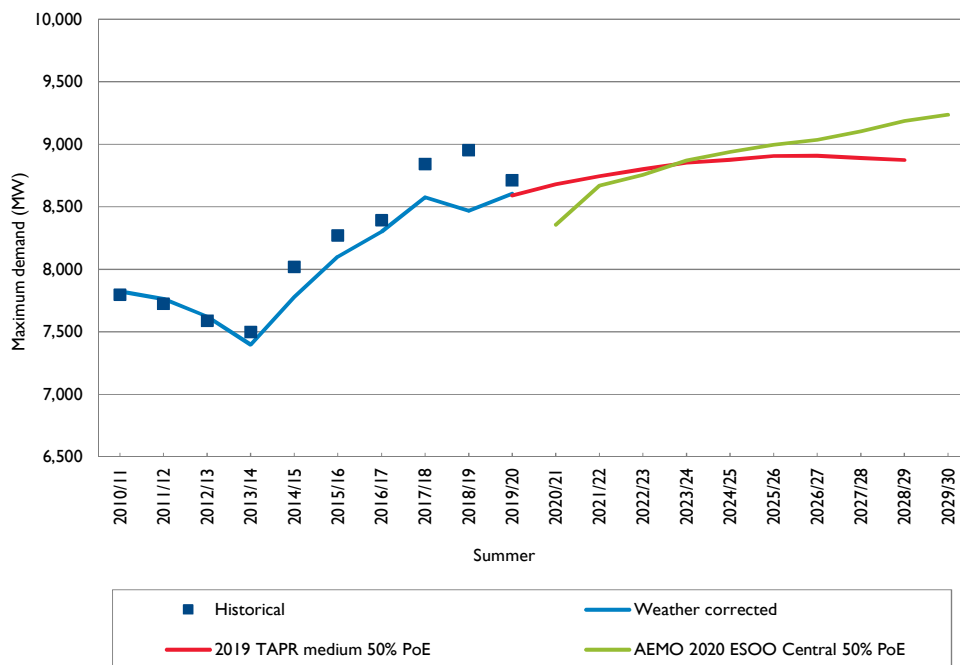

Notes:

- (1) AEMO's 2020 ESOO forecast has been converted from 'operational sent-out' to 'transmission delivered' for the purposes of comparison. Refer to Figure 2.6 for further details.
- (2) AEMO's 2020 ESOO forecast has been adjusted for future uncommitted distribution connected renewables by Powerlink to incorporate the Queensland Government's target of 50% renewable energy by 2030.

Figure 2.4 shows a comparison of Powerlink's 2019 TAPR delivered energy forecast based on medium economic outlook with AEMO's 2020 ESOO based on the Central scenario. Again, the reduction of energy in the short-term is due to the forecast COVID-19 pandemic impacts. Section 2.3 discusses updates included in AEMO's 2020 ESOO forecasts.

<sup>2</sup> Clean Energy Regulator, [Postcode data for small-scale installations – all data, data as at 30/09/2020](#), October 2020. Whilst RET legislation allows a 12 month creation period for registered persons to create their certificates, updates for the first 9 months of this window are generally not material.

## 2 Energy and demand projections

**Figure 2.4** Comparison of the 2019 TAPR medium economic outlook energy forecast with AEMO's 2020 ESOO Central scenario (1)(2)



Notes:

- (1) AEMO's 2020 ESOO forecast has been converted from 'operational sent-out' to 'transmission delivered' for the purposes of comparison. Refer to Figure 2.6 for further details.
- (2) AEMO's 2020 ESOO forecast has been adjusted for future uncommitted distribution connected renewables by Powerlink to incorporate the Queensland Government's target of 50% renewable energy by 2030.

### 2.2 Customer consultation

In accordance with the National Electricity Rules (NER), Powerlink has obtained summer and winter maximum demand forecasts over a 10-year outlook period from Queensland's DNSPs, Energex and Ergon Energy (part of the Energy Queensland group). These connection supply point forecasts are presented in Appendix A. Also in accordance with the NER, Powerlink has obtained summer and winter maximum demand forecasts from other customers that connect directly to the Powerlink transmission network.

Powerlink, Energex and Ergon Energy jointly conduct the Queensland Household Energy Survey (QHES) to improve understanding of consumer behaviours and intentions. This survey provides comprehensive insights on consumer intentions on electricity usage.

#### Transmission customer forecasts

##### *New large loads*

No new large loads have connected or have committed to connect in the outlook period.

##### *Possible new large loads*

There are several proposals under development for large mining, metal processing and other industrial loads. These have not been included in AEMO's 2020 ESOO Central scenario. These developments totalling nearly 1,250MW, are listed in Table 2.1.

**Table 2.1** Possible large loads excluded from the Slow Change, Central and Step Change scenario forecasts

Zone	Description	Possible load
Ross	Connection to North West Minerals Province (Mt Isa)	Up to 350MW
North	Further port expansion at Abbot Point	Up to 100MW
North	CSG load (Bowen Basin area)	Up to 80MW
North and Central West	New coal mining load (Galilee Basin area)	Up to 400MW
Surat	CSG load and coal mining projects (Surat Basin area)	Up to 300MW

## 2.3 Demand forecast outlook

The following sections outline the Queensland forecasts for energy, summer maximum demand, winter maximum demand, summer minimum demand and winter minimum demand. Annual maximum demands continue to be expected in the summer period. Annual minimum demands have generally occurred in the winter period. AEMO's 2020 ESOO<sup>3</sup> Central scenario forecast predicts the annual operational sent out minimum demand to shift to the shoulder period from 2024. Transmission delivered shoulder forecasts were not available for this 2020 TAPR, however the winter minimum demand provides a good representation of the annual minimum demand.

The annual minimum demand has moved from overnight to the daytime since 2018 (this is described in Section 2.3.1). The forecast for minimum delivered demand is now closely correlated to rooftop PV installations and embedded variable renewable energy (VRE) generators. Forecasts in this chapter are provided without predicting market outcomes, directions or constraints which may be imposed to ensure system security but impact on the output of these embedded VRE generators.

The 2019 TAPR forecasts were prepared for three economic outlooks, high, medium and low. For the 2020 TAPR the Slow Change, Central and Step Change scenarios from AEMO's 2020 ESOO forecast are used. Noticeably, the Slow Change scenario assumes extended COVID-19 restrictions and the loss of a large industrial load by summer 2029/30<sup>4</sup>. Demand forecasts are also prepared to account for seasonal variation. These seasonal variations are referred to as 10% PoE, 50% PoE and 90% PoE forecasts. They represent conditions that would expect to be exceeded once in 10 years, five times in 10 years and nine times in 10 years respectively.

The forecast average annual growth rates for the Queensland region over the next 10 years under Slow Change, Central and Step Change scenarios are shown in Table 2.2. These growth rates refer to transmission delivered quantities as described in Section 2.3.2. For summer and winter maximum demand, growth rates are based on 50% PoE corrected values for 2019/20 and 2019 respectively.

**Table 2.2** Average annual growth rate over next 10 years

	AEMO future scenario growth outlooks		
	Slow Change	Central	Step Change
Delivered energy	-3.0%	-0.7%	-0.7%
Delivered summer maximum demand (50% PoE)	-1.6%	0.7%	1.2%
Delivered winter maximum demand (50% PoE)	-1.3%	1.0%	1.7%

<sup>3</sup> Available in [AEMO's Forecasting Data Portal](#).

<sup>4</sup> AEMO, [2020 Electricity Demand Forecasting Methodology Paper](#), August 2020.

## 2 Energy and demand projections

### 2.3.1 Changing load profiles

Historically, the daily load profile as delivered by the Powerlink transmission grid has seen daily maximum demand occur in the mid afternoon during the summer seasons, and during evening periods within the cooler winter seasons. Daily minimum demands have typically occurred during the night time (typically 4am or so) when industries and commercial premises are mostly closed and households are sleeping.

However, the installation of small scale rooftop PV systems and distribution connected solar farms is progressively changing the characteristics of daily demand required to be supplied by the Powerlink high voltage transmission system. The uptake of rooftop PV systems within Queensland has been one of the highest per capita rates in the world, and there are now over 700,000 installed solar PV systems with an aggregate state-wide capacity of more than 3,300MW<sup>5</sup>.

While the cumulative effect of small scale renewable energy has reduced maximum demand and energy consumption, power produced by embedded solar installations has the effect of 'hollowing' the daily demand profile during the daytime period. This contribution ceases during the evening when the sun sets. This effect is more likely to be prominent within Queensland during the lower daytime demand winter and spring seasons. The term 'duck curve' was first coined by the Californian Independent System Operator to describe the effects of embedded solar power generation on the shape of the daily load profile, and is a characteristic experienced by transmission networks globally where there has been a significant level of embedded renewable energy systems.

Figure 2.5 depicts the change in daily load profile of the transmission delivered minimum demand daily profile. The duck curve can be seen to emerge creating a new annual minimum demand in the middle of the day from 2018.

**Figure 2.5** Transmission delivered annual minimum demand for the Queensland region (1)(2)

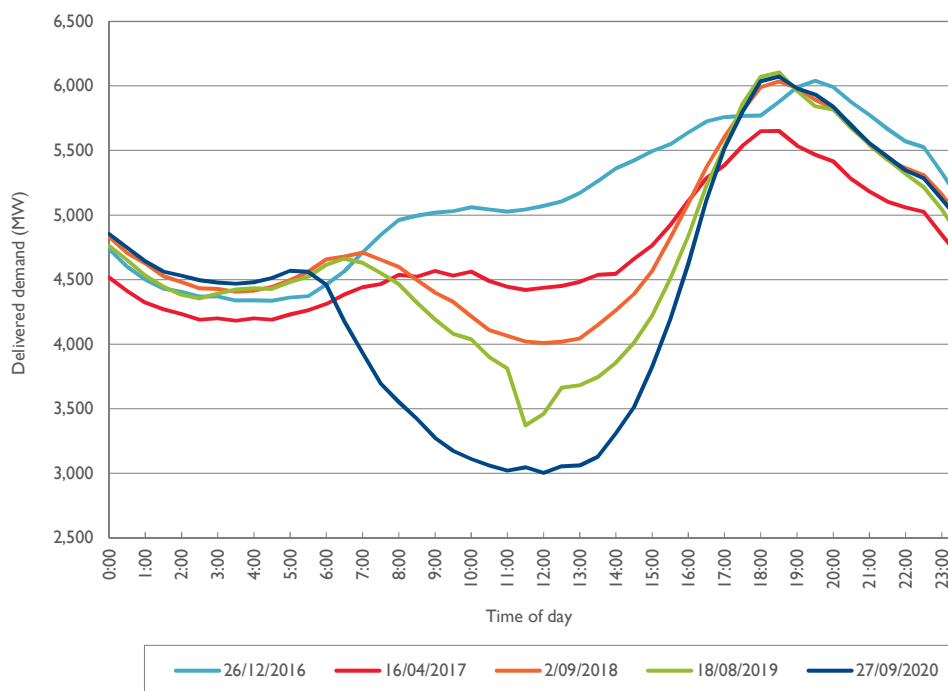

Notes:

- (1) Minimum demand can be caused by abnormal conditions, as depicted in the 2019 trace when lowest demand coincided with a large industrial load being out of service.
- (2) September 2020 minimum based on preliminary metering data.

<sup>5</sup> Clean Energy Regulator, [Postcode data for small-scale installations – all data](#), September 2020.

Minimum demand during the day has continued to decrease with the progressive installation of rooftop PV systems. However maximum daily demand has continued to increase in line with underlying load growth since the contribution of rooftop PV tapers off towards the evening. This has resulted in an increasing divergence between minimum and maximum demand which needs to be met and managed by generation and the transmission network.

This change in load profile has also meant that daytime minimum demand is now lower than night time for a significant portion of the year. This has meant that reactive power devices historically installed to manage night time minimum demand may no longer be sufficient to manage voltages during daytime periods.

The uptake of rooftop PV systems is expected to continue within residential and commercial premises. Should this trend progress in the absence of energy storage devices (such as household battery systems) or significant levels of demand time of day shifting, minimum demand is expected to further decrease with continued widening between maximum and minimum demand. The installation of additional reactive devices and/or non-network solutions are likely to be required to manage voltages during minimum demand conditions (refer sections 5.7.4 and 5.7.10).

Continuation of this trend is likely to present further challenges to the energy system. Generating stations will be required to ramp up and down in response to daily demand variations more frequently. Decreasing minimum demand may lower the amount of synchronous generation that is able to be on-line and this could further impact on voltage control, system strength and the ability for available generators to meet evening peak demand. However there may be opportunities for new technologies and non-network solutions to assist with managing the daily peaks and troughs. Demand shifting and storage solutions have the potential to smooth the daily load profile. These type of services could offer a number of benefits to the electricity system including reducing the need for additional transmission investment.

Powerlink is continuing to monitor and assess the impacts of changing load profiles on the transmission network, and is taking an integrated planning approach to address emerging issues and challenges with the transitioning energy system.

### **2.3.2 Demand and energy terminology**

The reported demand and energy on the network depends on where it is being measured. Individual stakeholders have reasons to measure demand and energy at different points. Figure 2.6 shows the common ways demand and energy measurements are defined, with this terminology used consistently throughout the TAPR.

# 2 Energy and demand projections

Figure 2.6 Load measurement definitions

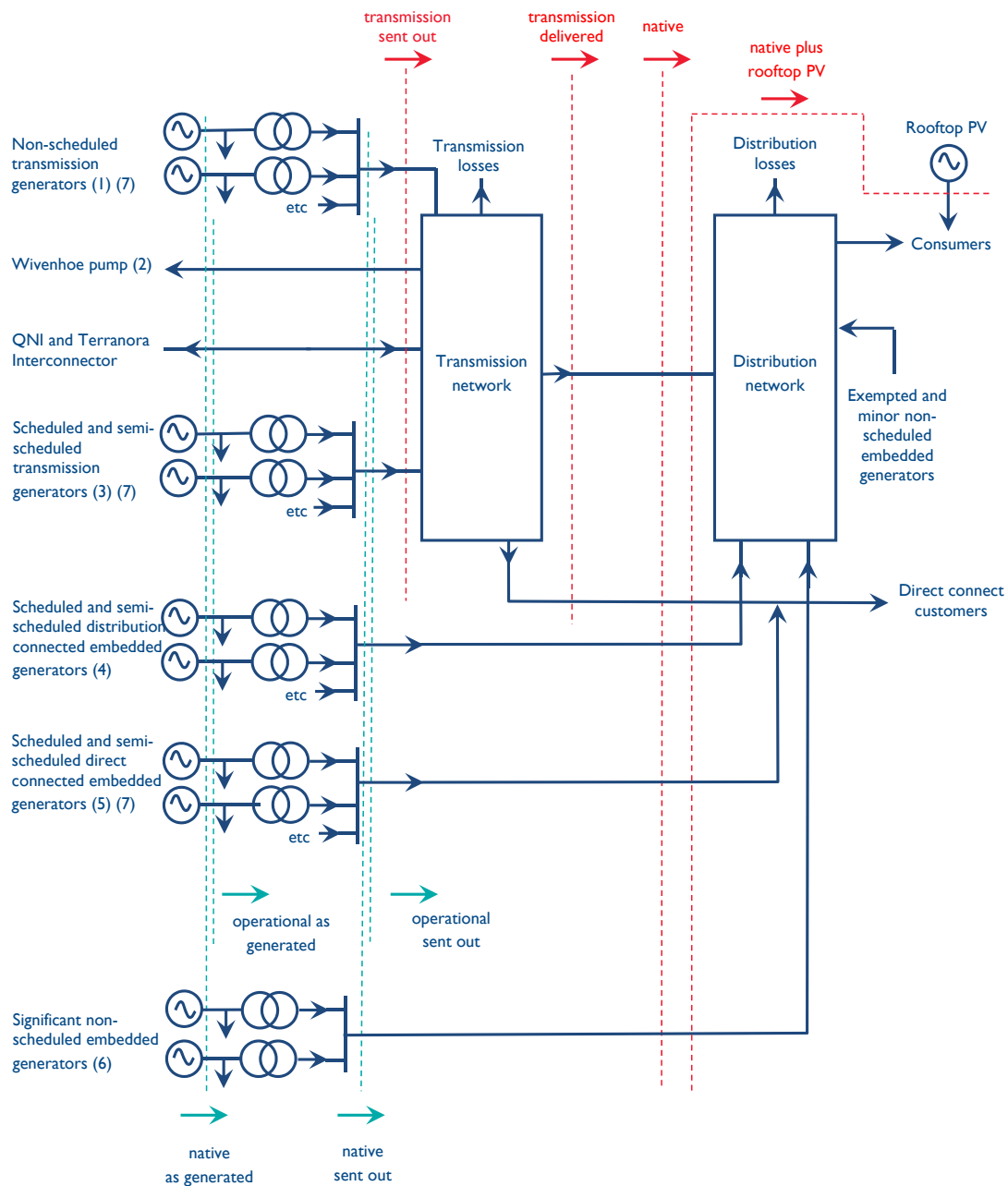

Notes:

- (1) Includes Invicta and Koombooloomba.
- (2) Depends on Wivenhoe generation.
- (3) Includes Yarwun which is non-scheduled.
- (4) For a full list of scheduled and semi-scheduled distribution connected generators refer to Table 6.2.
- (5) Sun Metals Solar Farm and Condamine.
- (6) Lakeland Solar and Storage, Hughenden Solar Farm, Pioneer Mill, Moranbah North, Moranbah, Racecourse Mill, Barcaldine Solar Farm, Longreach Solar Farm, German Creek, Oaky Creek, Isis Central Sugar Mill, Baking Board Solar Farm, Daandine, Sunshine Coast Solar Farm, Bromelton and Rocky Point.
- (7) For a full list of transmission network connected generators and scheduled and semi-scheduled direct connected embedded generators refer to Table 6.1.

### 2.3.3 Energy forecast

Historical Queensland energy measurements are presented in Table 2.3. They are recorded at various levels in the network as defined in Figure 2.6.

Transmission losses are the difference between transmission sent out and transmission delivered energy. Scheduled power station auxiliaries are the difference between Operational as generated and Operational sent out energy.

**Table 2.3** Historical energy (GWh)

Financial Year	Operational as generated	Operational sent out	Native as generated	Native sent out	Transmission sent out	Transmission delivered	Native	Native plus rooftop PV
2010/11	51,381	47,804	52,429	48,976	46,866	45,240	47,350	47,350
2011/12	51,147	47,724	52,206	48,920	46,980	45,394	47,334	47,334
2012/13	50,711	47,368	52,045	48,702	47,259	45,651	47,090	47,090
2013/14	49,686	46,575	51,029	47,918	46,560	45,145	46,503	46,503
2014/15	51,855	48,402	53,349	50,047	48,332	46,780	48,495	49,952
2015/16	54,238	50,599	55,752	52,223	50,573	49,094	50,744	52,509
2016/17	55,101	51,323	56,674	53,017	51,262	49,880	51,635	53,506
2017/18	54,538	50,198	56,139	51,918	50,172	48,739	50,925	53,406
2018/19	54,861	50,473	56,381	52,118	50,163	48,764	51,240	54,529
2019/20	54,179	50,039	55,776	51,740	49,248	47,860	50,804	54,449

The transmission delivered energy forecasts are presented in Table 2.4.

**Table 2.4** Forecast annual transmission delivered energy (GWh)

Financial Year	Slow Change	Central	Step Change
2020/21	42,429	45,303	47,034
2021/22	42,915	46,078	47,315
2022/23	43,121	46,382	46,636
2023/24	43,259	46,611	45,819
2024/25	43,494	46,258	44,744
2025/26	43,576	45,811	43,471
2026/27	43,661	45,335	43,624
2027/28	43,504	44,971	43,389
2028/29	43,560	44,707	44,045
2029/30 (1)	35,373	44,413	44,395

Note:

(1) AEMO assumes the shutdown of a large industrial load in the Slow Change scenario in summer 2029/30.

The historical annual transmission delivered energy from Table 2.3 and the forecast transmission delivered energy for the Slow Change, Central and Step Change scenarios from Table 2.4 are shown in Figure 2.7.



## 2 Energy and demand projections

**Figure 2.7** Historical and forecast transmission delivered energy

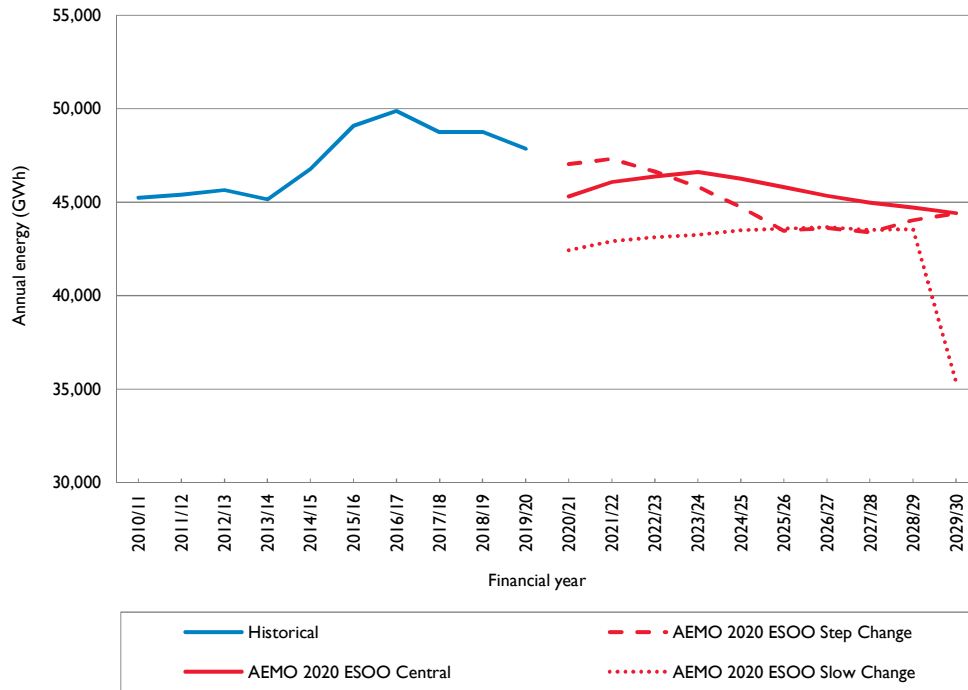

The native energy forecasts are presented in Table 2.5.

**Table 2.5** Forecast annual native energy (GWh)

Financial Year	Slow Change	Central	Step Change
2020/21	46,266	49,140	50,871
2021/22	46,867	50,030	51,267
2022/23	47,110	50,371	51,119
2023/24	47,224	50,577	50,909
2024/25	47,452	50,650	50,866
2025/26	47,563	50,657	50,742
2026/27	47,556	50,650	50,795
2027/28	47,506	50,772	50,856
2028/29	47,414	50,981	51,276
2029/30 (1)	39,297	51,172	51,824

Note:

(1) AEMO assumes the shutdown of a large industrial load in the Slow Change scenario in summer 2029/30.

### 2.3.4 Summer maximum demand forecast

Historical Queensland summer maximum demand measurements at time of native peak are presented in Table 2.6.

**Table 2.6** Historical summer maximum demand (MW)

Summer	Operational as generated	Operational sent out	Native as generated	Native sent out	Transmission sent out	Transmission delivered	Native	Native plus rooftop PV	Native corrected to 50% PoE
2010/11	8,826	8,299	8,895	8,374	8,020	7,797	8,152	8,152	8,187
2011/12	8,714	8,236	8,769	8,319	7,983	7,723	8,059	8,059	8,101
2012/13	8,479	8,008	8,691	8,245	7,920	7,588	7,913	7,913	7,952
2013/14	8,374	7,947	8,531	8,114	7,780	7,498	7,831	7,831	7,731
2014/15	8,831	8,398	9,000	8,589	8,311	8,019	8,326	8,512	8,084
2015/16	9,154	8,668	9,272	8,848	8,580	8,271	8,539	8,783	8,369
2016/17	9,412	8,886	9,584	9,062	8,698	8,392	8,756	8,899	8,666
2017/18	9,796	9,262	10,010	9,480	9,133	8,842	9,189	9,594	8,924
2018/19	10,044	9,450	10,216	9,626	9,240	8,951	9,415	9,685	8,930
2019/20	9,853	9,294	10,074	9,515	9,011	8,710	9,268	9,652	9,163

The summer transmission delivered maximum demand forecasts are presented in Table 2.7.

**Table 2.7** Forecast summer transmission delivered maximum demand (MW)

Summer	Slow Change			Central			Step Change		
	90% PoE	50% PoE	10% PoE	90% PoE	50% PoE	10% PoE	90% PoE	50% PoE	10% PoE
2020/21 (1)	7,139	7,438	7,765	8,018	8,357	8,738	8,305	8,668	9,044
2021/22 (2)	7,436	7,768	8,083	8,280	8,669	9,072	8,403	8,800	9,220
2022/23	7,629	7,935	8,292	8,384	8,756	9,183	8,454	8,819	9,271
2023/24	7,739	8,054	8,407	8,472	8,871	9,302	8,503	8,890	9,339
2024/25	7,797	8,107	8,445	8,540	8,940	9,339	8,616	8,976	9,403
2025/26	7,830	8,175	8,519	8,585	8,995	9,425	8,707	9,090	9,504
2026/27	7,841	8,193	8,546	8,619	9,036	9,444	8,829	9,197	9,604
2027/28	7,859	8,214	8,562	8,651	9,105	9,522	8,957	9,334	9,725
2028/29	7,880	8,249	8,596	8,732	9,186	9,574	9,137	9,490	9,929
2029/30 (3)	6,987	7,311	7,700	8,803	9,236	9,669	9,351	9,688	10,117

Notes:

- (1) Reduction in consumption in the Central and Slow Change scenarios due to forecast COVID-19 impacts in 2020/21.
- (2) Reduction in consumption in the Slow Change scenario due to forecast COVID-19 impacts in 2021/22.
- (3) Shutdown of a large industrial load is assumed in the Slow Change scenario in summer 2029/30.

The summer historical transmission delivered maximum demands from Table 2.6 and the forecast 50% PoE summer transmission delivered maximum demands for the Slow Change, Central, and Step Change scenarios from Table 2.7 are shown in Figure 2.8.

## 2 Energy and demand projections

**Figure 2.8** Historical and forecast transmission delivered summer maximum demand

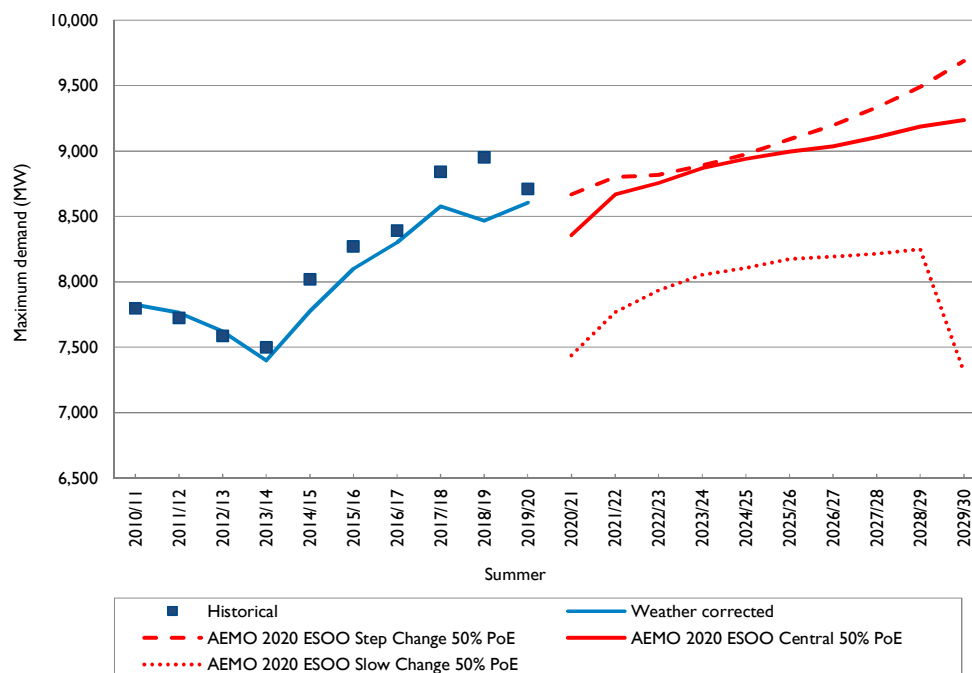

The summer native maximum demand forecasts are presented in Table 2.8.

**Table 2.8** Forecast summer native maximum demand (MW)

Summer	Slow Change			Central			Step Change		
	90% PoE	50% PoE	10% PoE	90% PoE	50% PoE	10% PoE	90% PoE	50% PoE	10% PoE
2020/21 (1)	7,824	8,123	8,450	8,703	9,042	9,423	8,990	9,353	9,729
2021/22 (2)	8,121	8,453	8,768	8,965	9,354	9,758	9,092	9,489	9,909
2022/23	8,315	8,620	8,978	9,069	9,441	9,868	9,146	9,511	9,963
2023/24	8,424	8,739	9,093	9,157	9,556	9,987	9,200	9,588	10,037
2024/25	8,482	8,792	9,130	9,225	9,626	10,024	9,318	9,678	10,105
2025/26	8,515	8,860	9,204	9,272	9,683	10,113	9,413	9,796	10,210
2026/27	8,526	8,879	9,231	9,309	9,727	10,134	9,535	9,903	10,310
2027/28	8,544	8,899	9,247	9,342	9,796	10,212	9,663	10,040	10,431
2028/29	8,565	8,934	9,281	9,427	9,882	10,270	9,843	10,196	10,635
2029/30 (3)	7,672	7,996	8,385	9,501	9,934	10,366	10,056	10,394	10,823

Notes:

- (1) Reduction in consumption in the Central and Slow Change scenarios due to forecast COVID-19 impacts in 2020/21.
- (2) Reduction in consumption in the Slow Change scenario due to forecast COVID-19 impacts in 2021/22.
- (3) Shutdown of a large industrial load is assumed in the Slow Change scenario in summer 2029/30.

### 2.3.5 Winter maximum demand forecast

Historical Queensland winter maximum demand measurements at time of native peak are presented in Table 2.9. As winter demand normally peaks after sunset, solar PV has no impact on winter maximum demand.

**Table 2.9** Historical winter maximum demand (MW)

Winter	Operational as generated	Operational sent out	Native as generated	Native sent out	Transmission sent out	Transmission delivered	Native	Native plus rooftop PV	Native corrected to 50% PoE
2011	7,632	7,207	7,816	7,400	7,093	6,878	7,185	7,185	6,998
2012	7,469	7,081	7,520	7,128	6,955	6,761	6,934	6,934	6,908
2013	7,173	6,753	7,345	6,947	6,699	6,521	6,769	6,769	6,983
2014	7,307	6,895	7,470	7,077	6,854	6,647	6,881	6,881	6,999
2015	7,822	7,369	8,027	7,620	7,334	7,126	7,411	7,412	7,301
2016	8,017	7,513	8,188	7,686	7,439	7,207	7,454	7,454	7,479
2017	7,723	7,221	7,874	7,374	7,111	6,894	7,157	7,157	7,433
2018	8,172	7,623	8,295	7,750	7,554	7,383	7,633	7,633	7,904
2019	8,073	7,559	8,286	7,778	7,416	7,208	7,624	7,624	7,617
2020	8,143	7,671	8,320	7,885	7,673	7,441	7,708	7,708	(1)

Note:

(1) The winter 2020 weather corrected demand was not available at time of publication.

The winter transmission delivered maximum demand forecasts are presented in Table 2.10.

**Table 2.10** Forecast winter transmission delivered maximum demand (MW)

Winter	Slow Change			Central			Step Change		
	90% PoE	50% PoE	10% PoE	90% PoE	50% PoE	10% PoE	90% PoE	50% PoE	10% PoE
2021 (1)	6,237	6,475	6,776	7,012	7,265	7,576	7,215	7,473	7,793
2022	6,535	6,772	7,086	7,227	7,489	7,806	7,347	7,618	7,964
2023	6,683	6,930	7,237	7,316	7,590	7,917	7,401	7,683	8,017
2024	6,729	6,971	7,298	7,384	7,661	8,016	7,463	7,757	8,131
2025	6,780	7,026	7,333	7,431	7,709	8,053	7,573	7,854	8,234
2026	6,814	7,065	7,361	7,491	7,762	8,098	7,697	7,978	8,357
2027	6,831	7,078	7,380	7,526	7,808	8,145	7,830	8,119	8,487
2028	6,838	7,106	7,438	7,587	7,882	8,271	7,972	8,278	8,713
2029	6,857	7,105	7,425	7,652	7,943	8,303	8,162	8,463	8,859
2030 (2)	5,965	6,214	6,530	7,715	8,010	8,391	8,383	8,689	9,130

Notes:

(1) Reduction in consumption in the Slow Change scenarios due to forecast COVID-19 impacts in 2021.

(2) Shutdown of a large industrial load is assumed in the Slow Change scenario in summer 2029/30.

## 2 Energy and demand projections

The winter historical transmission delivered maximum demands from Table 2.9 and the forecast 50% PoE summer transmission delivered maximum demands for the Slow Change, Central, and Step Change scenarios from Table 2.10 are shown in Figure 2.9.

**Figure 2.9** Historical and forecast winter transmission delivered maximum demand

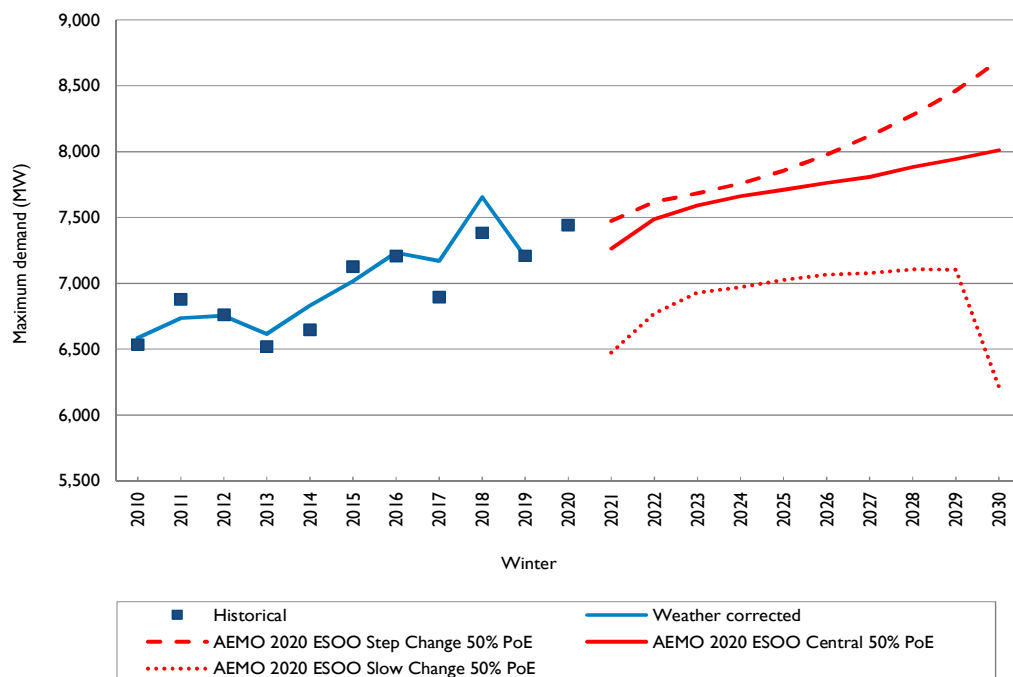

The winter native maximum demand forecasts are presented in Table 2.11.

**Table 2.11** Forecast winter native maximum demand (MW)

Winter	Slow Change			Central			Step Change		
	90% PoE	50% PoE	10% PoE	90% PoE	50% PoE	10% PoE	90% PoE	50% PoE	10% PoE
2021 (1)	6,706	6,944	7,245	7,481	7,734	8,044	7,683	7,942	8,261
2022	7,003	7,241	7,554	7,695	7,957	8,275	7,823	8,094	8,441
2023	7,152	7,399	7,706	7,784	8,059	8,386	7,884	8,166	8,501
2024	7,198	7,440	7,766	7,852	8,130	8,484	7,956	8,251	8,624
2025	7,249	7,495	7,802	7,900	8,179	8,523	8,075	8,356	8,736
2026	7,283	7,533	7,829	7,965	8,235	8,571	8,206	8,487	8,867
2027	7,300	7,547	7,848	8,005	8,286	8,624	8,340	8,629	8,997
2028	7,307	7,574	7,907	8,065	8,361	8,750	8,483	8,788	9,223
2029	7,325	7,573	7,893	8,142	8,433	8,792	8,672	8,974	9,370
2030 (2)	6,434	6,683	6,999	8,209	8,503	8,884	8,893	9,199	9,640

Notes:

- (1) Reduction in consumption in the Slow Change scenarios due to forecast COVID-19 impacts in 2021.
- (2) Shutdown of a large industrial load is assumed in the Slow Change scenario in summer 2029/30.

### 2.3.6 Summer minimum demand forecast

Historical Queensland summer minimum demand measurement at time of delivered minimum are presented in Table 2.12.

**Table 2.12** Historical summer minimum demand (MW)

Summer	Operational as generated	Operational sent out	Native as generated	Native sent out	Transmission sent out	Transmission delivered	Native	Native plus rooftop PV
2010/11	4,055	3,684	4,155	3,784	3,603	3,476	3,657	3,657
2011/12	4,041	4,285	4,127	4,371	4,204	3,506	3,673	3,673
2012/13	4,095	4,408	4,220	4,521	4,397	3,610	3,734	3,734
2013/14	4,176	4,400	4,305	4,540	4,411	3,702	3,831	3,831
2014/15	4,313	3,993	4,523	4,236	4,027	3,914	4,123	4,123
2015/16	4,652	4,234	4,772	4,354	4,234	4,109	4,228	4,228
2016/17	4,944	4,470	5,101	4,627	4,471	4,336	4,493	4,493
2017/18	4,773	4,313	4,949	4,489	4,314	4,190	4,366	4,366
2018/19	4,847	4,294	5,033	4,485	4,097	3,984	4,372	5,980
2019/20	4,530	4,039	4,727	4,270	3,855	3,688	4,103	5,453

The summer transmission delivered minimum demand forecasts are presented in Table 2.13.

**Table 2.13** Forecast summer transmission delivered minimum demand (MW)

Summer	Slow Change			Central			Step Change		
	90% PoE	50% PoE	10% PoE	90% PoE	50% PoE	10% PoE	90% PoE	50% PoE	10% PoE
2020/21 (1)	3,086	3,207	3,320	3,536	3,662	3,768	3,678	3,793	3,906
2021/22 (2)	3,076	3,204	3,324	3,495	3,636	3,753	3,151	3,314	3,446
2022/23	2,997	3,134	3,258	3,398	3,541	3,671	2,702	2,863	3,017
2023/24	2,926	3,055	3,184	3,309	3,447	3,589	2,076	2,249	2,408
2024/25	2,900	3,037	3,165	2,938	3,092	3,234	1,107	1,303	1,477
2025/26	2,882	3,029	3,162	2,730	2,888	3,038	344	553	732
2026/27	2,861	3,010	3,148	2,319	2,485	2,643	178	388	583
2027/28	2,810	2,975	3,121	1,975	2,151	2,314	-285	-65	150
2028/29	2,717	2,885	3,035	1,504	1,695	1,873	-496	-259	-41
2029/30 (3)	1,774	1,930	2,073	1,260	1,436	1,612	-643	-409	-185

Notes:

- (1) Reduction in consumption in the Central and Slow Change scenarios due to forecast COVID-19 impacts in 2020/21.
- (2) Reduction in consumption in the Slow Change scenario due to forecast COVID-19 impacts in 2021/22.
- (3) Shutdown of a large industrial load is assumed in the Slow Change scenario in summer 2029/30.

The summer historical transmission delivered maximum demands from Table 2.12 and the forecast 50% PoE summer transmission delivered minimum demands for the Slow Change, Central, and Step Change scenarios from Table 2.13 are shown in Figure 2.10.

## 2 Energy and demand projections

Figure 2.10 Historical and forecast transmission delivered summer minimum demand

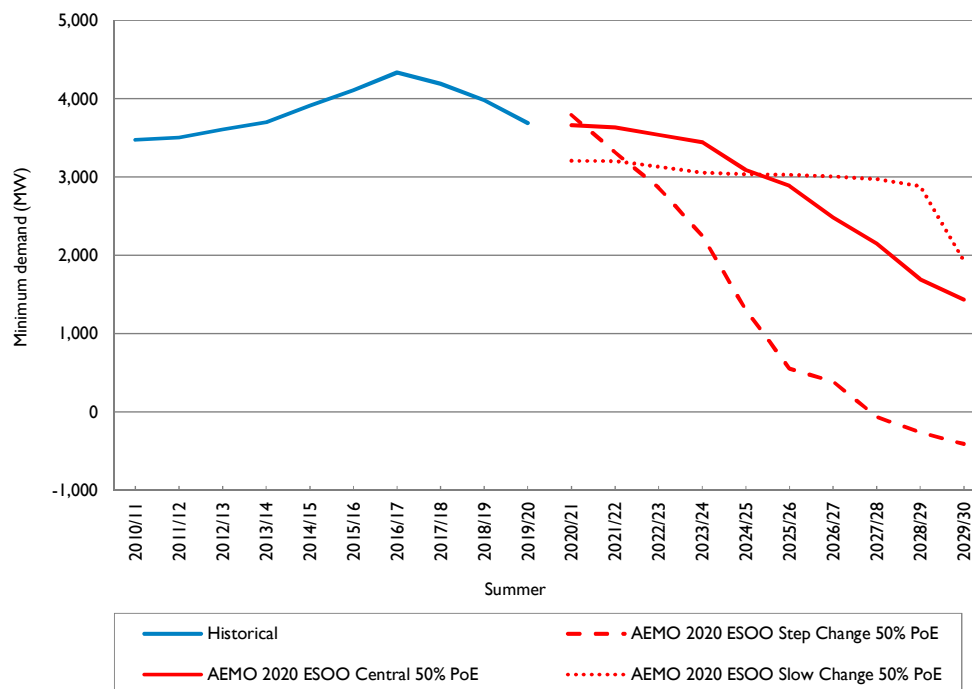

The summer native minimum demand forecasts are presented in Table 2.14.

Table 2.14 Forecast summer native minimum demand (MW)

Summer	Slow Change			Central			Step Change		
	90% PoE	50% PoE	10% PoE	90% PoE	50% PoE	10% PoE	90% PoE	50% PoE	10% PoE
2020/21 (1)	3,892	4,013	4,127	4,342	4,468	4,574	4,484	4,600	4,712
2021/22 (2)	3,882	4,010	4,130	4,301	4,443	4,559	4,097	4,261	4,392
2022/23	3,803	3,940	4,064	4,204	4,347	4,478	3,768	3,929	4,083
2023/24	3,732	3,861	3,990	4,115	4,253	4,395	3,327	3,501	3,659
2024/25	3,706	3,843	3,972	3,885	4,039	4,181	2,717	2,913	3,087
2025/26	3,688	3,835	3,968	3,746	3,905	4,055	2,220	2,429	2,608
2026/27	3,667	3,817	3,954	3,517	3,683	3,841	2,063	2,273	2,467
2027/28	3,616	3,781	3,927	3,321	3,497	3,660	1,720	1,939	2,155
2028/29	3,524	3,691	3,842	3,040	3,232	3,409	1,509	1,746	1,964
2029/30 (3)	2,580	2,736	2,879	2,904	3,080	3,257	1,362	1,596	1,820

Notes:

- (1) Reduction in consumption in the Central and Slow Change scenarios due to forecast COVID-19 impacts in 2020/21.
- (2) Reduction in consumption in the Slow Change scenario due to forecast COVID-19 impacts in 2021/22.
- (3) Shutdown of a large industrial load is assumed in the Slow Change scenario in summer 2029/30.

### 2.3.7 Winter minimum demand forecast

Historical Queensland winter minimum demands at time of delivered minimum are presented in Table 2.15.

**Table 2.15** Historical winter minimum demand (MW)

Winter	Operational as generated	Operational sent out	Native as generated	Native sent out	Transmission sent out	Transmission delivered	Native	Native plus rooftop PV
2011	4,334	3,959	4,442	4,066	3,815	3,696	3,947	3,947
2012	4,158	4,642	4,254	4,729	4,550	3,629	3,808	3,808
2013	4,172	4,737	4,365	4,980	4,787	3,800	3,992	3,992
2014	4,073	3,780	4,274	4,022	3,768	3,664	3,918	3,918
2015	4,281	3,946	4,476	4,178	3,983	3,884	4,079	4,079
2016	4,958	4,500	5,123	4,670	4,505	4,382	4,547	4,547
2017	4,791	4,313	4,942	4,468	4,318	4,181	4,331	4,331
2018	4,647	4,165	4,868	4,421	4,143	4,008	4,286	5,492
2019	4,211	3,712	4,441	3,978	3,528	3,370	3,820	5,190
2020 (1)	3,897	3,493	4,094	3,728	3,097	3,003	3,634	5,841

Note:

(1) Winter 2020 based on preliminary metering data.

The winter transmission delivered minimum demand forecasts are presented in Table 2.16.

**Table 2.16** Forecast winter transmission delivered minimum demand (MW)

Winter	Slow Change			Central			Step Change		
	90% PoE	50% PoE	10% PoE	90% PoE	50% PoE	10% PoE	90% PoE	50% PoE	10% PoE
2021 (1)	2,726	2,874	3,001	3,073	3,221	3,353	3,094	3,248	3,380
2022	2,686	2,839	2,975	3,023	3,178	3,319	2,609	2,776	2,922
2023	2,644	2,792	2,923	2,939	3,106	3,245	2,176	2,345	2,489
2024	2,601	2,753	2,884	2,871	3,033	3,168	1,562	1,733	1,885
2025	2,569	2,727	2,858	2,499	2,668	2,809	569	745	911
2026	2,543	2,695	2,829	2,281	2,444	2,597	-220	-33	134
2027	2,497	2,651	2,788	1,845	2,014	2,163	-411	-228	-52
2028	2,444	2,603	2,737	1,504	1,668	1,817	-876	-701	-521
2029	2,388	2,551	2,695	1,078	1,252	1,414	-1,033	-841	-653
2030 (2)	1,482	1,641	1,784	818	988	1,147	-1,163	-961	-764

Notes:

(1) Reduction in consumption in the Slow Change scenarios due to forecast COVID-19 impacts in 2021.

(2) Shutdown of a large industrial load is assumed in the Slow Change scenario in summer 2029/30.

The winter historical transmission delivered minimum demands from Table 2.15 and the forecast 50% PoE summer transmission delivered minimum demands for the Slow Change, Central, and Step Change scenarios from Table 2.16 are shown in Figure 2.11.



## 2 Energy and demand projections

**Figure 2.11** Historical and forecast winter transmission delivered minimum demand

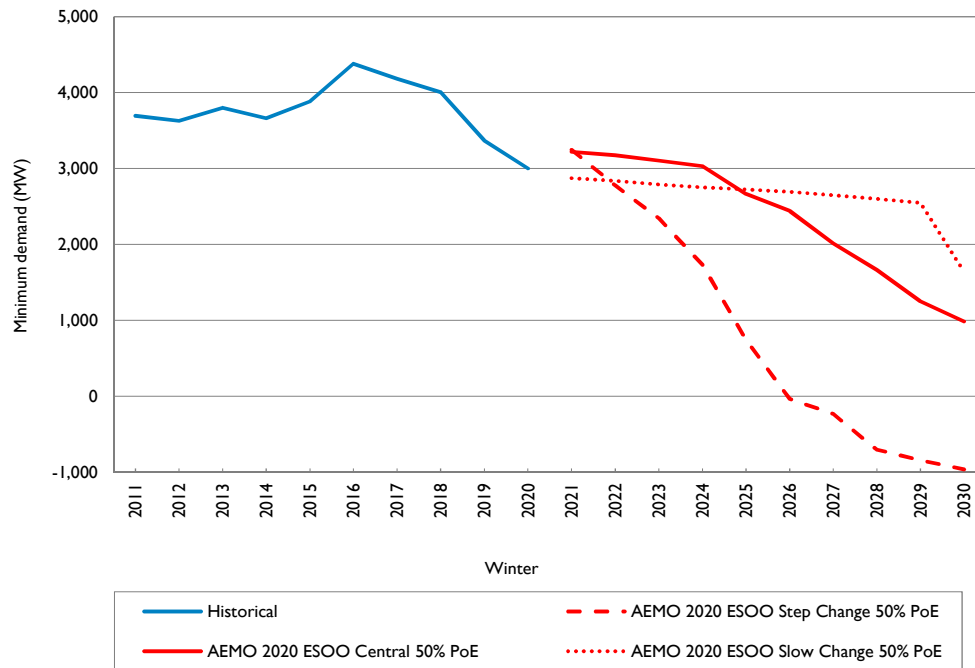

The winter native minimum demand forecasts are presented in Table 2.17.

**Table 2.17** Forecast winter native minimum demand (MW)

Winter	Slow Change			Central			Step Change		
	90% PoE	50% PoE	10% PoE	90% PoE	50% PoE	10% PoE	90% PoE	50% PoE	10% PoE
2021 (1)	3,654	3,802	3,929	4,001	4,149	4,281	4,022	4,176	4,308
2022 (2)	3,614	3,767	3,903	3,951	4,106	4,247	3,678	3,845	3,991
2023	3,572	3,720	3,851	3,867	4,034	4,173	3,364	3,533	3,676
2024	3,529	3,681	3,812	3,799	3,961	4,096	2,935	3,105	3,258
2025	3,497	3,655	3,785	3,568	3,736	3,878	2,301	2,477	2,643
2026	3,471	3,623	3,757	3,419	3,582	3,735	1,778	1,965	2,132
2027	3,425	3,579	3,716	3,164	3,334	3,482	1,596	1,778	1,954
2028	3,372	3,531	3,665	2,972	3,136	3,285	1,250	1,426	1,606
2029	3,316	3,479	3,623	2,736	2,910	3,072	1,093	1,285	1,473
2030 (3)	2,410	2,569	2,712	2,584	2,754	2,913	963	1,165	1,363

Notes:

- (1) Reduction in consumption in the Slow Change scenarios due to forecast COVID-19 impacts in 2021.
- (2) Shutdown of a large industrial load is assumed in the Slow Change scenario in summer 2029/30.

## 2.4 Zone forecasts

AEMO's 2020 ESOO provides forecasts for Queensland as a single region. Forecasts from DNSPs and directly connected customers at each transmission connection supply point have been used to apportion the demand and energy forecasts into the 11 zones referenced throughout this TAPR. The 11 geographical zones are defined in Table C.1 and illustrated in Figure C.1 in Appendix C. In the 2014 TAPR Powerlink split the South West zone into Surat and South West zones. Each zone normally experiences its own maximum demand, which is usually greater than that shown in tables 2.21 to 2.24.

Table 2.18 shows the average ratios of zone maximum transmission delivered demand to zone transmission delivered demand at the time of Queensland region maximum delivered demand. These values can be used to multiply demands in tables 2.21 and 2.23 to estimate each zone's individual maximum transmission delivered demand, the time of which is not necessarily coincident with the time of Queensland region maximum transmission delivered demand. The ratios are based on historical trends.

**Table 2.18** Average ratios of zone maximum delivered demand to zone delivered demand at time of Queensland region maximum delivered demand

Zone	Winter	Summer
Far North	1.11	1.19
Ross	1.34	1.65
North	1.10	1.16
Central West	1.10	1.25
Gladstone	1.03	1.05
Wide Bay	1.03	1.11
Surat	1.14	1.15
Bulli	1.05	1.07
South West	1.04	1.09
Moreton	1.03	1.01
Gold Coast	1.03	1.01

Tables 2.19 and 2.20 show the forecast of transmission delivered energy and native energy for the Central scenario for each of the 11 zones in the Queensland region.

## 2 Energy and demand projections

**Table 2.19** Annual transmission delivered energy by zone (GWh)

Financial Year	Far North	Ross	North	Central West	Gladstone	Wide Bay	Surat	Bulli	South West	Moreton	Gold Coast	Total
Actuals												
2010/11	1,810	2,791	2,590	3,152	10,118	1,308		95	1,082	18,886	3,408	45,240
2011/12	1,792	2,723	2,611	3,463	10,286	1,323		105	1,196	18,629	3,266	45,394
2012/13	1,722	2,693	2,732	3,414	10,507	1,267		103	1,746	18,232	3,235	45,651
2013/14	1,658	2,826	2,828	3,564	10,293	1,321	338	146	1,304	17,782	3,085	45,145
2014/15	1,697	2,977	2,884	3,414	10,660	1,266	821	647	1,224	18,049	3,141	46,780
2015/16	1,724	2,944	2,876	3,327	10,721	1,272	2,633	1,290	1,224	17,944	3,139	49,094
2016/17	1,704	2,682	2,661	3,098	10,196	1,305	4,154	1,524	1,308	18,103	3,145	49,880
2017/18	1,657	2,645	2,650	3,027	9,362	1,238	4,383	1,497	1,315	17,873	3,092	48,739
2018/19	1,648	2,338	2,621	2,996	9,349	1,198	4,805	1,519	1,376	17,849	3,065	48,764
2019/20	1,594	2,466	2,495	2,859	9,303	1,031	5,025	1,580	1,141	17,395	2,971	47,860
Forecasts												
2020/21	1,550	2,036	2,449	2,462	9,365	864	5,175	1,623	663	16,325	2,791	45,303
2021/22	1,568	2,188	2,560	2,571	9,415	875	5,217	1,636	664	16,545	2,839	46,078
2022/23	1,587	2,204	2,575	2,598	9,426	886	5,238	1,642	670	16,684	2,872	46,382
2023/24	1,602	2,219	2,594	2,621	9,432	896	5,244	1,644	672	16,789	2,898	46,611
2024/25	1,571	2,161	2,530	2,555	9,438	872	5,145	1,615	639	16,827	2,905	46,258
2025/26	1,532	2,096	2,455	2,476	9,436	846	5,031	1,582	605	16,843	2,909	45,811
2026/27	1,493	2,025	2,381	2,395	9,435	818	4,885	1,539	568	16,881	2,915	45,335
2027/28	1,455	1,956	2,303	2,314	9,434	789	4,770	1,505	528	16,982	2,935	44,971
2028/29	1,419	1,886	2,230	2,241	9,434	756	4,656	1,472	486	17,158	2,969	44,707
2029/30	1,378	1,817	2,150	2,156	9,433	729	4,517	1,431	449	17,348	3,005	44,413

**Table 2.20** Annual native energy by zone (GWh)

Financial Year	Far North	Ross	North	Central West	Gladstone	Wide Bay	Surat	Bulli	South West	Moreton	Gold Coast	Total
<b>Actuals</b>												
2010/11	1,810	3,220	2,879	3,500	10,118	1,328		95	2,013	18,979	3,408	47,350
2011/12	1,792	3,217	2,901	3,710	10,286	1,348		105	2,014	18,695	3,266	47,334
2012/13	1,722	3,080	3,064	3,767	10,507	1,292		103	1,988	18,332	3,235	47,090
2013/14	1,658	3,067	3,154	3,944	10,293	1,339	402	146	1,536	17,879	3,085	46,503
2014/15	1,697	3,163	3,434	3,841	10,660	1,285	1,022	647	1,468	18,137	3,141	48,495
2015/16	1,724	3,141	3,444	3,767	10,721	1,293	2,739	1,290	1,475	18,011	3,139	50,744
2016/17	1,704	2,999	3,320	3,541	10,196	1,329	4,194	1,524	1,549	18,134	3,145	51,635
2017/18	1,667	2,935	3,296	3,493	9,362	1,259	4,853	1,497	1,527	17,944	3,092	50,925
2018/19	1,670	2,894	3,211	3,608	9,349	1,266	5,163	1,519	1,550	17,945	3,065	51,240
2019/20	1,614	2,899	3,159	3,656	9,303	1,282	5,395	1,580	1,479	17,466	2,971	50,804
<b>Forecasts</b>												
2020/21	1,567	2,676	3,134	3,367	9,365	1,197	5,510	1,623	1,505	16,405	2,791	49,140
2021/22	1,585	2,937	3,245	3,478	9,415	1,209	5,553	1,636	1,509	16,624	2,839	50,030
2022/23	1,607	2,958	3,266	3,511	9,426	1,223	5,584	1,645	1,516	16,763	2,872	50,371
2023/24	1,619	2,971	3,281	3,530	9,432	1,231	5,582	1,645	1,519	16,869	2,898	50,577
2024/25	1,621	2,971	3,282	3,534	9,438	1,232	5,596	1,649	1,516	16,906	2,905	50,650
2025/26	1,617	2,968	3,277	3,529	9,436	1,231	5,603	1,651	1,512	16,924	2,909	50,657
2026/27	1,614	2,965	3,276	3,526	9,435	1,230	5,579	1,644	1,508	16,958	2,915	50,650
2027/28	1,612	2,963	3,271	3,524	9,434	1,231	5,590	1,648	1,505	17,059	2,935	50,772
2028/29	1,611	2,958	3,271	3,529	9,434	1,224	5,601	1,652	1,496	17,236	2,969	50,981
2029/30	1,607	2,956	3,266	3,523	9,433	1,225	5,589	1,648	1,493	17,427	3,005	51,172

## 2 Energy and demand projections

Tables 2.21 and 2.22 show the forecast of transmission delivered summer maximum demand and native summer maximum demand for each of the 11 zones in the Queensland region. It is based on the central scenario and average summer weather.

**Table 2.21** State summer maximum transmission delivered demand by zone (MW)

Summer	Far North	Ross	North	Central West	Gladstone	Wide Bay	Surat	Bulli	South West	Moreton	Gold Coast	Total
Actuals												
2010/11	306	339	371	469	1,172	274		18	175	3,990	683	7,797
2011/12	296	376	405	525	1,191	249		18	217	3,788	658	7,723
2012/13	277	303	384	536	1,213	232		14	241	3,754	634	7,588
2013/14	271	318	353	493	1,147	260	30	21	291	3,711	603	7,498
2014/15	278	381	399	466	1,254	263	130	81	227	3,848	692	8,019
2015/16	308	392	412	443	1,189	214	313	155	231	3,953	661	8,271
2016/17	269	291	392	476	1,088	276	447	175	309	3,957	712	8,392
2017/18	304	376	414	464	1,102	278	557	183	301	4,145	718	8,842
2018/19	338	319	389	445	1,104	289	518	191	313	4,314	731	8,951
2019/20	287	293	372	334	1,084	234	623	191	273	4,299	720	8,710
Forecasts												
2020/21	278	265	433	441	1,074	242	494	198	216	4,035	681	8,357
2021/22	286	293	466	461	1,076	256	501	200	225	4,204	701	8,669
2022/23	288	285	484	463	1,076	264	504	201	227	4,255	709	8,756
2023/24	293	291	491	470	1,078	268	505	201	232	4,325	717	8,871
2024/25	296	295	495	474	1,078	272	507	202	235	4,363	723	8,940
2025/26	298	298	498	480	1,079	275	508	202	238	4,392	727	8,995
2026/27	301	302	500	486	1,079	278	505	200	241	4,415	729	9,036
2027/28	303	305	502	487	1,080	281	506	201	243	4,462	735	9,105
2028/29	306	309	505	490	1,080	285	507	201	247	4,513	743	9,186
2029/30	309	312	505	490	1,080	288	505	200	250	4,548	749	9,236

**Table 2.22** State summer maximum native demand by zone (MW)

Summer	Far North	Ross	North	Central West	Gladstone	Wide Bay	Surat	Bulli	South West	Moreton	Gold Coast	Total
<b>Actuals</b>												
2010/11	306	412	408	551	1,172	274		18	337	3,991	683	8,152
2011/12	296	449	434	598	1,191	249		18	378	3,788	658	8,059
2012/13	277	417	422	568	1,213	241		14	328	3,799	634	7,913
2013/14	271	423	386	561	1,147	260	88	21	316	3,755	603	7,831
2014/15	278	399	479	548	1,254	263	189	81	254	3,889	692	8,326
2015/16	308	423	491	519	1,189	214	370	155	257	3,952	661	8,539
2016/17	269	364	512	559	1,088	276	498	175	329	3,974	712	8,756
2017/18	310	480	486	508	1,102	278	617	183	328	4,179	718	9,189
2018/19	338	456	432	562	1,104	293	630	191	340	4,337	731	9,415
2019/20	287	451	441	530	1,084	277	660	191	305	4,322	720	9,268
<b>Forecasts</b>												
2020/21	280	457	509	574	1,074	266	617	198	327	4,059	681	9,042
2021/22	288	484	543	594	1,076	281	624	200	337	4,226	701	9,354
2022/23	290	476	561	597	1,076	288	628	201	338	4,277	709	9,441
2023/24	295	482	568	604	1,078	293	628	201	343	4,347	717	9,556
2024/25	298	486	571	608	1,078	296	631	202	346	4,387	723	9,626
2025/26	300	490	575	614	1,079	299	632	202	349	4,416	727	9,683
2026/27	303	494	578	620	1,079	303	630	201	353	4,437	729	9,727
2027/28	305	497	579	622	1,080	306	631	201	355	4,485	735	9,796
2028/29	309	502	583	625	1,080	310	633	202	359	4,536	743	9,882
2029/30	311	505	583	625	1,080	314	631	201	362	4,573	749	9,934

## 2 Energy and demand projections

Tables 2.23 and 2.24 show the forecast of transmission delivered winter maximum demand and native winter maximum demand for each of the 11 zones in the Queensland region. It is based on the central scenario and average winter weather.

**Table 2.23** State winter maximum transmission delivered demand by zone (MW)

Winter	Far North	Ross	North	Central West	Gladstone	Wide Bay	Surat	Bulli	South West	Moreton	Gold Coast	Total
Actuals												
2011	230	216	317	432	1,155	222		22	376	3,303	605	6,878
2012	214	212	326	426	1,201	215		20	346	3,207	594	6,761
2013	195	249	348	418	1,200	190	23	17	263	3,039	579	6,521
2014	226	346	359	463	1,200	204	16	51	257	2,974	551	6,647
2015	192	289	332	429	1,249	203	172	137	258	3,268	597	7,126
2016	216	278	341	451	1,229	193	467	193	280	3,009	550	7,207
2017	218	290	343	366	1,070	220	520	182	247	2,912	526	6,894
2018	242	366	336	440	1,091	235	527	186	336	3,084	540	7,383
2019	229	207	321	433	1,066	241	502	207	316	3,154	532	7,208
2020	227	306	327	449	1,104	246	531	191	313	3,232	515	7,441
Forecasts												
2021	222	276	375	459	1,108	224	433	216	280	3,138	534	7,265
2022	227	298	405	474	1,109	234	439	218	287	3,247	551	7,489
2023	230	288	425	478	1,110	241	442	219	291	3,307	559	7,590
2024	233	292	430	483	1,111	244	443	219	294	3,346	566	7,661
2025	233	292	429	482	1,111	244	444	219	294	3,389	572	7,709
2026	234	293	429	485	1,111	245	444	219	295	3,429	578	7,762
2027	234	293	428	486	1,110	246	441	218	295	3,472	585	7,808
2028	234	293	425	483	1,110	247	441	218	295	3,539	597	7,882
2029	234	292	422	479	1,108	247	441	218	294	3,601	607	7,943
2030	235	294	421	477	1,108	249	441	218	296	3,657	614	8,010

**Table 2.24** State winter maximum native demand by zone (MW)

Winter	Far North	Ross	North	Central West	Gladstone	Wide Bay	Surat	Bulli	South West	Moreton	Gold Coast	Total
Actuals												
2011	230	339	360	520	1,155	222		22	428	3,304	605	7,185
2012	214	289	360	460	1,201	215		20	375	3,206	594	6,934
2013	195	291	374	499	1,200	195	89	17	290	3,040	579	6,769
2014	226	369	420	509	1,200	204	90	51	286	2,975	551	6,881
2015	192	334	404	518	1,249	203	208	137	288	3,281	597	7,411
2016	216	358	419	504	1,229	200	467	193	310	3,008	550	7,454
2017	218	367	416	415	1,070	220	554	182	276	2,913	526	7,157
2018	242	360	410	494	1,091	235	654	186	336	3,085	540	7,633
2019	230	307	408	483	1,066	241	628	207	346	3,176	532	7,624
2020	227	329	406	492	1,104	247	624	191	342	3,231	515	7,708
Forecasts												
2021	222	378	450	511	1,108	226	642	216	304	3,143	534	7,734
2022	227	399	480	526	1,109	237	648	218	311	3,251	551	7,957
2023	230	390	500	531	1,110	243	651	219	314	3,312	559	8,059
2024	233	393	505	536	1,111	246	651	219	318	3,352	566	8,130
2025	233	394	504	535	1,111	247	653	219	318	3,392	572	8,178
2026	234	395	504	538	1,111	248	654	219	319	3,433	578	8,233
2027	235	395	503	539	1,110	249	651	218	319	3,477	585	8,281
2028	235	396	501	536	1,110	250	651	219	319	3,542	597	8,356
2029	235	395	498	533	1,108	250	652	219	319	3,606	607	8,422
2030	236	397	498	532	1,108	253	653	219	321	3,659	615	8,491



## 2 Energy and demand projections

### 2.5 Summer and winter minimum and maximum daily profiles

The daily load profiles (transmission delivered) for the Queensland region on the days of summer 2019/20 and winter 2020 native maximum demands are shown in Figure 2.12.

**Figure 2.12** Daily load profile of summer 2019/20 and winter 2020 maximum transmission delivered demand days

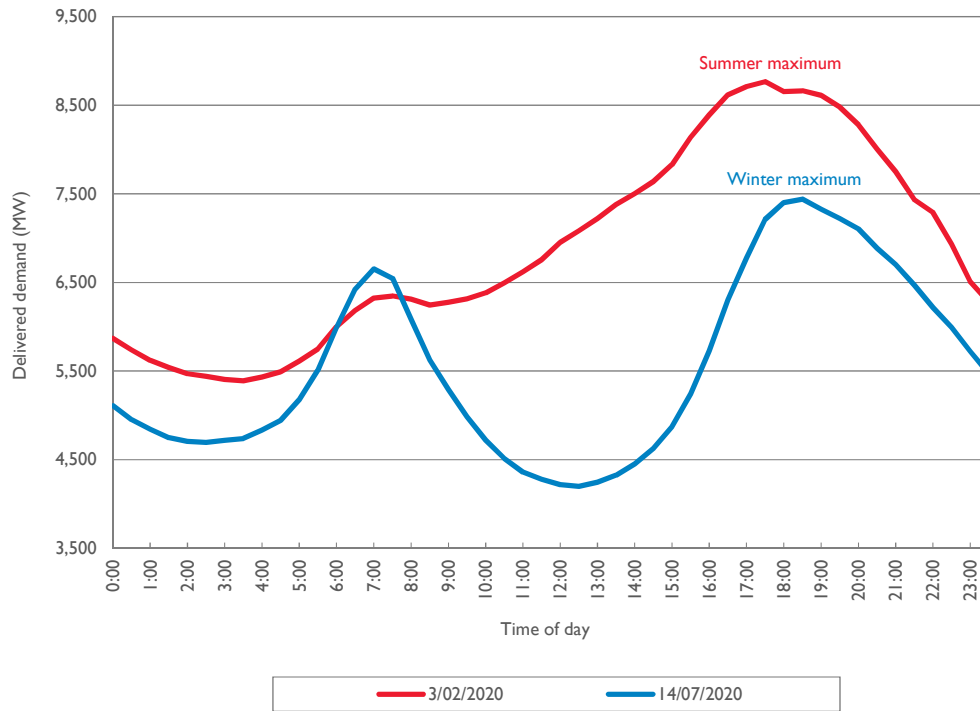

The daily load profiles (transmission delivered) for the Queensland region on the days of summer 2019/20 and winter 2020 delivered minimum demands are shown in Figure 2.13.

**Figure 2.13** Daily load profile of summer 2019/20 and winter 2020 minimum transmission delivered demand days (I)

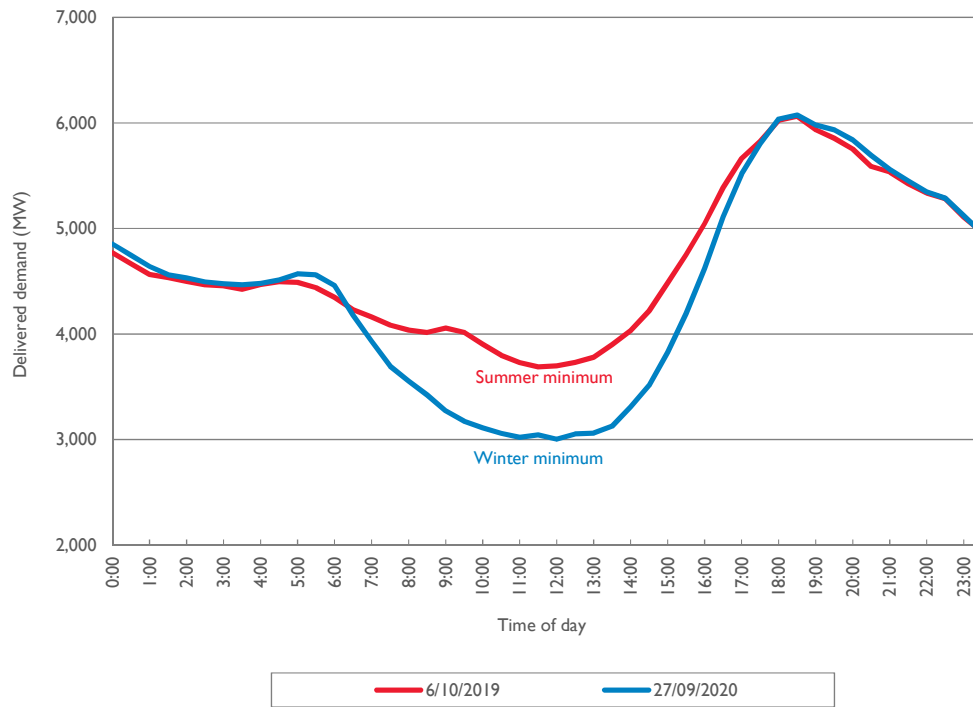

Note:

(I) September 2020 trace based on preliminary metering data

## 2 Energy and demand projections

### 2.6 Annual load duration curves

The annual historical normalised cumulative load duration curves for the Queensland region transmission delivered demand since 2015/16 is shown in Figure 2.14.

**Figure 2.14** Historical normalised transmission delivered load duration curves

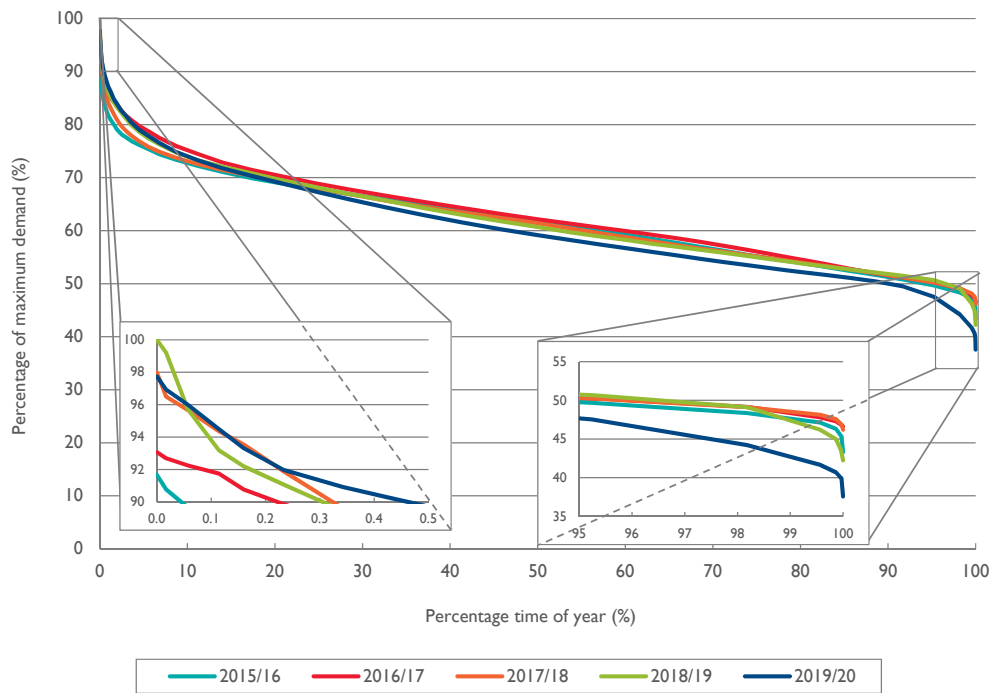

## **CHAPTER 3**

# Joint planning

- 3.1 Introduction
- 3.2 Working groups and regular engagement
- 3.3 AEMO Integrated System Plan
- 3.4 AEMO National Planning - fault level shortfall
- 3.5 Power System Frequency Risk Review
- 3.6 Joint planning with TransGrid – Expanding the transmission transfer capacity between New South Wales and Queensland
- 3.7 Joint planning with Energex and Ergon Energy

# 3 Joint planning

## Key highlights

- Joint planning provides a mechanism for Network Service Providers (NSPs) to discuss and identify technically feasible, cost effective network or non-network options that address identified network needs regardless of asset ownership or jurisdictional boundaries.
- Key joint planning focus areas since the publication of the 2019 Transmission Annual Planning Report (TAPR) include:
  - the Integrated System Plan (ISP), Power System Frequency Risk Review (PSFRR) and Notice of Queensland System Strength Requirements and Ross Fault Level Shortfall with the Australian Energy Market Operator (AEMO)
  - publication of the Project Assessment Conclusion Report (PACR ) recommending expanding the transmission transfer capacity between New South Wales (NSW) and Queensland with TransGrid
  - the analysis of options to address condition driven reinvestments with Energex and Ergon Energy (part of the Energy Queensland Group).

## 3.1 Introduction

Powerlink's joint planning framework with AEMO and other NSPs is in accordance with the requirements set out in Clause 5.14.3 and 5.14.4 of National Electricity Rules (NER).

Joint planning begins several years in advance of an investment decision. The nature and timing of future investment needs are reviewed at least on an annual basis utilising an interactive joint planning approach.

The objective of joint planning is to collaboratively identify network and non-network solutions to limitations which best serve the long-term interests of customers, irrespective of the asset boundaries (including those between jurisdictions).

The joint planning process results in integrated area and inter-regional strategies which optimise asset investment needs and decisions consistent with whole of life asset planning.

The joint planning process is intrinsically iterative. The extent to which this occurs will depend upon the nature of the limitation or asset condition driver to be addressed and the complexity of the proposed corrective action. In general, joint planning seeks to:

- understand the issues collectively faced by the different network owners and operators
- understand existing and forecast congestion on power transfers between neighbouring regions
- help identify the most efficient options to address these issues, irrespective of the asset boundaries (including those between jurisdictions)
- influence how networks are managed, and what network changes are required.

Projects where a feasible network option exists which is greater than \$6 million are subject to a formal consultation process under the applicable regulatory investment test mechanism. The owner of the asset where the limitation emerges will determine whether a Regulatory Investment Test for Transmission (RIT-T) or Regulatory Investment Test for Distribution (RIT-D) is used as the regulatory instrument to progress the investment recommendation under the joint planning framework. This provides customers, stakeholders and interested parties the opportunity to provide feedback and discuss alternative solutions to address network needs. Ultimately, this process results in investment decisions which are prudent, transparent and aligned with stakeholder expectations.

## 3.2 Working groups and regular engagement

Powerlink collaborates with the other National Electricity Market (NEM) jurisdictional planners through a range of committees and groups.

### 3.2.1 Regular joint planning meetings

For the purpose of effective network planning, Powerlink has collaborated in regular joint planning meetings with:

- AEMO on the 2020 PSFRR (refer to Section 6.3)
- AEMO on the Network Support and Control Ancillary Service (refer to Section 5.5.1)
- AEMO and other jurisdictional planners in the development of the 2020 ISP published in July 2020 (refer to Section 7.4)
- AEMO National Planning to determine the minimum system strength requirements in the Queensland region and the subsequent notification of a fault level shortfall at the new Ross node
- TransGrid for the assessment of the economic benefits of expanding the transmission transfer capacity between Queensland and NSW (refer to Section 5.7.14)
- Energex and Ergon Energy for the purposes of efficiently planning developments and project delivery in the transmission and sub-transmission network.

## 3.3 AEMO ISP

Powerlink worked closely with AEMO to support the development of the 2020 ISP, published in July 2020. The ISP sets out a roadmap for the eastern seaboard's power system over the next two decades by establishing a whole of system plan for efficient development that achieves system needs through a period of 'transformational' change. Joint planning with AEMO is critical to ensure the best possible jurisdictional inputs are provided to the ISP process in the long-term interests of customers.

### Process

Powerlink continues to provide a range of network planning inputs to AEMO's ISP consultation and modelling processes, through joint planning processes and regular engagement, workshops and various formal consultations. This engagement helps underpin the inputs, assumptions and methodology for the ISP.

Powerlink provided feedback on the inputs and assumptions and reviewed the long-term network development strategy and findings of the 2020 Draft ISP (published in December 2019). This feedback and input included information on condition drivers for significant intra-regional infrastructure and possible network development options that increase capacity of critical intra and inter-regional grid sections, together with the associated capacity improvement.

AEMO's ISP continues to investigate opportunities for expansion of interconnector capacity. In the 2020 ISP, AEMO identified Queensland/New South Wales Interconnector (QNI) Medium and Large projects as future ISP projects, requiring Powerlink and TransGrid to undertake preparatory activities. These preparatory works are to be completed by 30 June 2021 such that the best possible inputs to the 2022 ISP are available (refer to Section 7.4).

Aligned with the findings from the Draft 2020 ISP, in December 2019, Powerlink and TransGrid released a PACR on 'Expanding NSW-Queensland transmission transfer capacity'. This is now an approved project (refer to Section 5.7.14).

### Methodology

More information on the 2020 ISP including methodology and assumptions is available on [AEMO's website](#).

### Outcomes

The ISP attempts to identify a long-term plan for the efficient development of the NEM transmission network, and the connection of Renewable Energy Zones (REZ) over the coming 20 years. It is based on a set of assumptions and a range of scenarios.

## 3 Joint planning

### 3.4 AEMO National Planning – Fault Level Shortfall

System strength is a critical requirement for a stable and secure power system. A minimum level of system strength is required for the power system to remain stable under normal conditions and to return to a steady state condition following a system disturbance.

Under the NER there is a responsibility on Powerlink to maintain a minimum level of fault level at key nodes. These key nodes, and prescribed minimum fault levels, are defined by AEMO in consultation with the respective Transmission Network Service Provider (TNSP).

During 2020 Powerlink worked closely with AEMO to review the Queensland fault level nodes and their minimum three phase fault levels. These replace the 2018 system strength requirements for Queensland and are defined in Section 8.4. Powerlink has also worked with AEMO to assess whether there is or is likely to be a fault level shortfall in the Queensland region, and a forecast of the period over which any fault level shortfall might exist.

#### Process

Powerlink and AEMO carried out detailed Electromagnetic Transient-type (EMT-type) analysis to determine the system strength requirements for the Queensland region. Using the outcomes from these studies (for example, minimum required synchronous generator combinations), minimum three phase fault levels at the fault level nodes are defined.

#### Methodology

AEMO applies the System Strength Requirements Methodology<sup>1</sup> to determine the Queensland fault level nodes and their minimum three phase fault levels for 2020.

More information on the System Strength Requirements Methodology, System Strength Requirements and Fault Level Shortfalls is available on AEMO's website.

#### Outcomes

AEMO published a Notice of Queensland System Strength Requirements and Ross Fault Level Shortfall in April 2020. There were two significant changes since their initial report in 2018:

- The replacement of the Nebo 275kV fault level node with the Ross 275kV node. In consultation with Powerlink, AEMO determined that the Ross 275kV node is a better representation for system strength conditions in North Queensland (NQ) compared to Nebo 275kV node.
- AEMO declared an immediate fault level shortfall of 90MVA at the Ross 275kV fault level node. AEMO forecast that, if not addressed, this fault level shortfall will continue beyond 2024-25. Under the NER, the responsibility to ensure that system strength services are available to address the fault level shortfall lies with Powerlink as the TNSP and Jurisdictional Planning Body (JPB) for the region.

These outcomes and Powerlink's proposed responses are discussed in Section 8.4.1.

### 3.5 Power System Frequency Risk Review (PSFRR)

The PSFRR is an integrated, periodic review of power system frequency risks associated with non-credible contingency events in the NEM.

#### Process

In accordance with Clause 5.20A.1 of the NER, AEMO in consultation with TNSPs prepares a PSFRR for the NEM, considering:

- Non-credible contingency events which AEMO expects could likely involve uncontrolled frequency changes leading to cascading outages or major supply disruption.
- Current arrangements for managing such non-credible contingency events.
- Options for future management of such events.
- The performance of existing Emergency Frequency Control Schemes (EFCS).

---

<sup>1</sup> AEMO, [System Strength Requirements Methodology and System Strength Requirements and Shortfalls](#), July 2018.

For 2020, AEMO is undertaking the PSFRR in two stages. Stage 1 reviews the status of actions recommended in the 2018 PSFRR, reviews power system events and identifies non-credible contingency events and associated management arrangements to be prioritised. Stage 2 includes more detailed assessment and option analysis and is to be published in December 2020.

### Methodology

With support from Powerlink, AEMO assessed the performance of existing EFCS. AEMO also assessed high priority non-credible contingency events identified in consultation with Powerlink.

From these assessments AEMO determined whether further action may be justified to manage frequency risks.

### Outcomes

The [Final 2020 PSFRR](#) – Stage 1 Report recommended:

- Expansion of Powerlink's Central Queensland to South Queensland (CQ-SQ) Special Protection Scheme (SPS). The existing scheme is limited to transfers lower than 1,700MW and relies on the ability to disconnect, up to two, high output generating units at Callide Power Stations for the unplanned trip of both Calvale to Halys 275kV feeders. Powerlink has initiated a project to implement new Wide area monitoring protection and control (WAMPAC) architecture into CQ-SQ SPS by mid-2021. The scheme is expected to include approximately 600MW of renewable generators and operate in parallel with the existing SPS (refer to Section 6.3).
- There are increasing risks associated with the existing CQ-SQ SPS. Higher southerly flows are becoming increasingly frequent as new generation projects come online in NQ. Powerlink will continue to work with AEMO and review the emerging risks to determine whether a protected event should be recommended to allow AEMO to manage the risk through operational measures ahead of changes to the SPS. Investigating the cost-benefit of this proposal will be completed in Stage 2 of the 2020 PSFRR due by the end of 2020.
- Stage 2 of the 2020 PSFRR will also review the requirement for an Over Frequency Generation Shedding (OFGS) scheme as a result of the QNI Minor upgrade.

## 3.6 Joint planning with TransGrid – Expanding the transmission transfer capacity between New South Wales and Queensland

In December 2019, Powerlink and TransGrid released a PACR on 'Expanding NSW-Queensland transmission transfer capacity'. The recommended option includes upgrading the 330kV Liddell to Tamworth 330kV lines, and installing Static VAr Compensators (SVCs) at Tamworth and Dumaresq substations and static capacitor banks at Tamworth, Armidale and Dumaresq substations. The project is expected to be completed by June 2022 at a cost of \$217 million. All material works associated with this upgrade are within TransGrid's network.

AEMO's ISP continues to investigate opportunities for expansion of interconnector capacity. In the 2020 ISP, AEMO identified QNI Medium and Large projects as future ISP projects, requiring Powerlink and TransGrid to undertake preparatory activities by 30 June 2021 (refer to Section 5.7.14).

AEMO also flagged in the 2020 ISP that it will work with Powerlink and TransGrid to explore further options in relation to Virtual transmission lines (VTLs). The 2020 ISP outlined that VTLs, coupled with suitable wide area protection systems, could provide a technically feasible solution to increase the capacity of QNI.



## 3 Joint planning

### 3.7 Joint planning with Energex and Ergon Energy

Queensland's Distribution Network Service Providers (DNSPs) Energex and Ergon Energy (part of the Energy Queensland group) participate in regular joint planning and coordination meetings with Powerlink to assess emerging limitations, including asset condition drivers, to ensure the recommended solution is optimised for efficient expenditure outcomes<sup>2</sup>. These meetings are held regularly to assess, in advance of any requirement for an investment decision by either NSP, matters that are likely to impact on the other NSP. Powerlink and the DNSPs then initiate detailed discussions around addressing emerging limitations as required. Joint planning also ensures that interface works are planned to ensure efficient delivery.

Table 3.1 provides a summary of activities that are utilised in joint planning. During preparation of respective regulatory submissions, the requirement for joint planning increases significantly and the frequency of some activities reflect this.

**Table 3.1** Joint planning activities

Activity	Frequency		
	Week-to-week	Monthly	Annual
Sharing and validating information covering specific issues	Y	Y	
Sharing updates to network data and models	Y	Y	
Identifying emerging limitations	Y		
Developing potential credible solutions	Y		
Estimating respective network cost estimates	Y		
Developing business cases	Y		
Preparing relevant regulatory documents	Y		
Sharing information for joint planning analysis	Y	Y	
Sharing information for respective works plans			Y
Sharing planning and fault level reports			Y
Sharing information for Regulatory Information Notices			Y
Sharing updates to demand forecasts			Y
Joint planning workshops			Y

#### 3.7.1 Matters requiring joint planning

The following is a summary of projects where detailed joint planning with Energex and Ergon Energy (and other NSPs as required) has occurred since the publication of the 2019 TAPR (refer to Table 3.2). There are a number of projects where Powerlink, Energex and Ergon Energy interface on delivery, changes to secondary systems or metering, and other relevant matters which are not covered in this Chapter. Further information on these projects, including timing and alternative options is discussed in Chapter 5.

**Table 3.2** Joint planning project references

Project	Reference
Cairns 132/22kV transformer replacement/retirement	<a href="#">Section 5.7.1</a>
Redbank Plains transformer and primary plant replacement	<a href="#">Section 5.7.10</a>
Mudgeeraba 275/110kV transformer replacement/retirement	<a href="#">Section 5.7.11</a>
SEQ reactive power and voltage control	<a href="#">Section 5.7.10</a>

<sup>2</sup> Where applicable to inform and in conjunction with the appropriate RIT-T consultation process.

## CHAPTER 4

# Asset management overview

- 4.1 Introduction
- 4.2 Overview of approach to asset management
- 4.3 Asset management policy
- 4.4 Asset management strategy
- 4.5 Asset management methodologies
- 4.6 Flexible and integrated network investment planning
- 4.7 Asset management implementation
- 4.8 Further information

# 4 Asset management overview

## Key highlights

- Powerlink is committed to prudent and sustainable asset management practices that consider and recognise our customer and stakeholder requirements.
- Powerlink's asset management practices provide safe, reliable, secure and environmentally conscious services that provide the platform to enable the transition to a more sustainable, cost efficient, and climate resilient energy system.
- Powerlink's approach to asset management:
  - delivers value to our customers and stakeholders by optimising whole of life cycle costs, benefits and risks while ensuring compliance with relevant legislation, regulations and standards
  - is underpinned by Powerlink's corporate risk management framework and good practice international risk assessment methodologies.

## 4.1 Introduction

Powerlink's asset management system captures significant internal and external drivers on the business and sets out initiatives to be adopted.

Other factors that influence network development, such as energy and demand forecasts, generation development (including asynchronous generation development and potential synchronous generation withdrawal), emerging industry trends and technology, and risks arising from the condition and performance of the existing asset base are also analysed collectively in order to form an integrated network investment plan over a 10-year outlook period.

## 4.2 Overview of approach to asset management

Powerlink's Asset Management System ensures assets are managed in a manner consistent with the Asset Management Policy and overall corporate objectives to deliver cost effective and efficient services. The principles set out in the Asset Management System (refer to Figure 4.1) and Asset Management Policy guides Powerlink's analysis of future network investment needs and key investment drivers.

Powerlink's asset management and joint planning approaches ensure asset reinvestment needs are not just considered on a like-for-like basis, rather the enduring need and most cost effect option are considered. A detailed analysis of both asset condition and network capability is performed prior to proposed reinvestment and where applicable, a Regulatory Investment Test for Transmission (RIT-T) is undertaken, in order to bring about optimised solutions that may involve network reconfiguration, retirement and/or non-network solutions.

Figure 4.1 Asset Management System

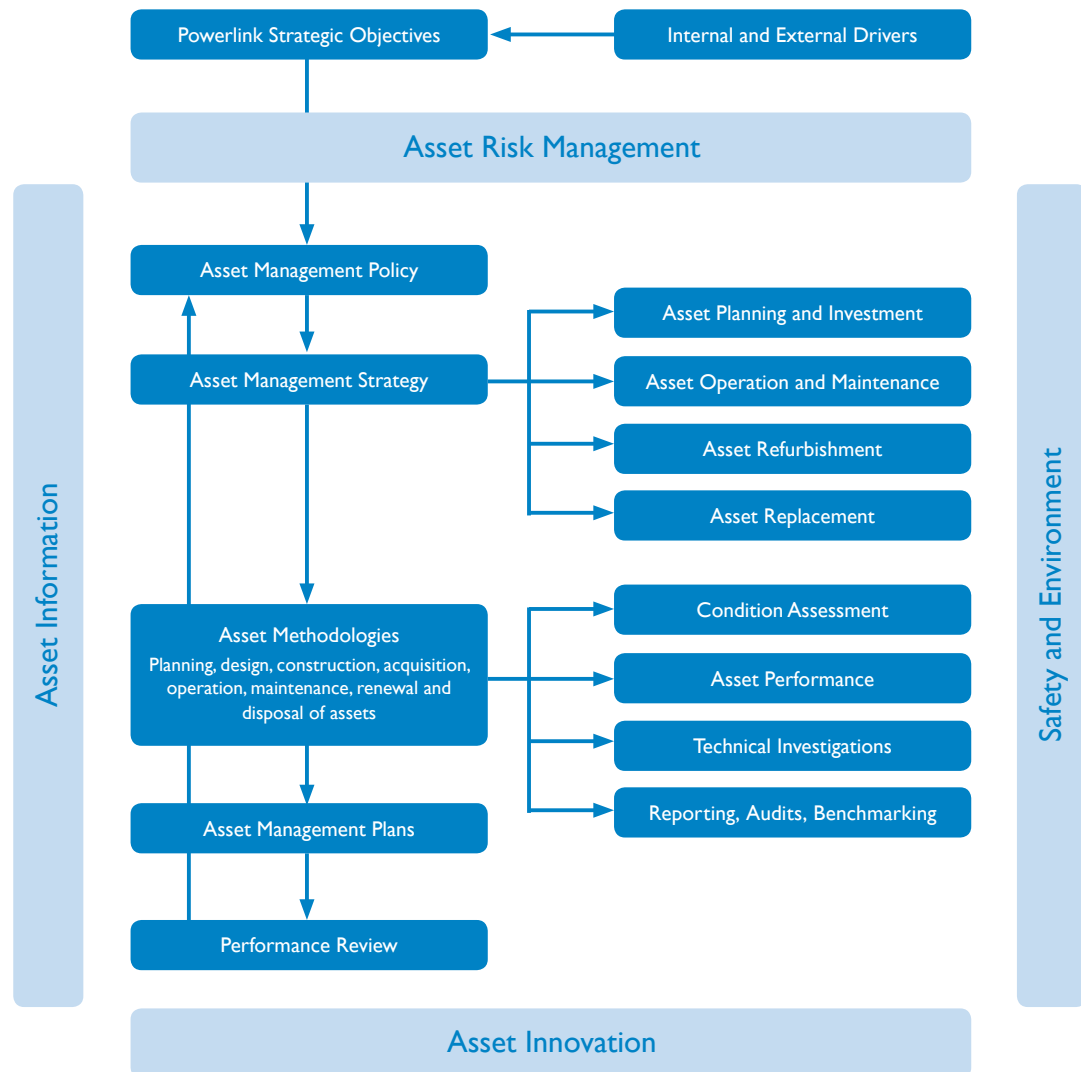

### 4.3 Asset Management Policy

Powerlink’s Asset Management Policy sets out a commitment to sustainable asset management practices that ensure Powerlink provides a valued transmission service to our customers’ needs by optimising whole of life cycle costs, benefits and risks while ensuring compliance with applicable legislation, regulations and standards.

The policy includes principles that are applied to manage Powerlink’s entire transmission network, including telecommunications and business infrastructure assets.

### 4.4 Asset Management Strategy

Powerlink’s Asset Management Strategy identifies the principles and the approach that guide the development of investment plans for the network, including such factors as expected service levels, technological changes, investment policy and risk management.

Powerlink’s Asset Management Strategy is based on two parallel aspects:

- Asset Life Cycle, which considers assets on a ‘whole of life’ basis
- Asset Management Cycle, which considers the broader business environment including continuous improvement from the review of evolving factors.

# 4 Asset management overview

Together, these complementary systems:

- enable a process of continuous improvement which focuses on providing valued services to customers by taking into account evolving internal and external factors (such as energy transition)
- provide a framework to ensure Powerlink’s obligations are able to be effectively and efficiently delivered.

## 4.4.1 Asset life cycle

A critical element of asset management is to consider the life cycle of assets. There are three primary timeframes in the life of an asset. These timeframes and the interaction between them over the life cycle of assets are shown in Figure 4.2.

Figure 4.2 Asset life cycle

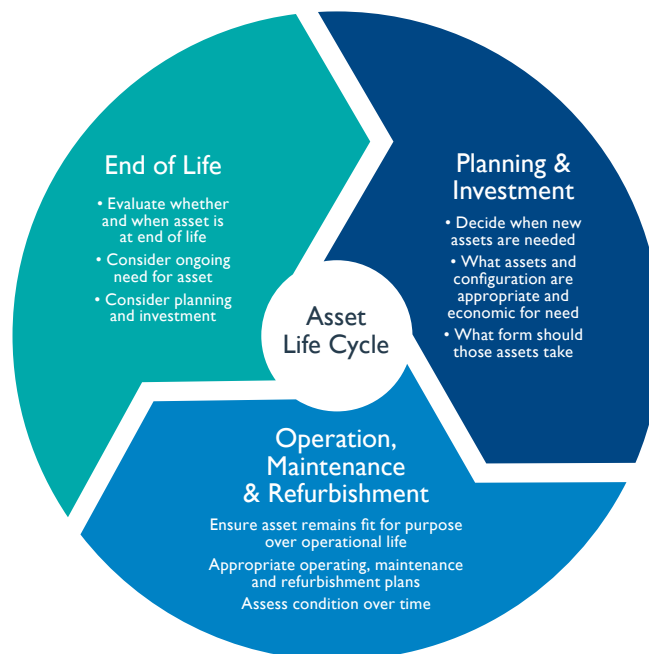

## 4.4.2 Asset management cycle

Powerlink’s asset management practices also consider the broader business environment. This includes operating and overarching business requirements such as safety and environment, risk and information management.

Powerlink manages these aspects by considering the asset management cycle and applying the four phases (refer to Figure 4.3).

### Phase 1 – Strategic alignment

*Assessing Powerlink’s obligations across a wide range of legislation and regulation, and determining the expectations of Powerlink’s customers and stakeholders.*

This assessment enables Powerlink to responsibly deliver electricity transmission services that are valued by stakeholders, customers and the market.

### Phase 2 – Asset management strategies

*Considering the obligations and expectations identified under the strategic alignment phase and determining how Powerlink responds in meeting or managing those obligations and expectations.*

By managing these obligations and expectations, Powerlink is aligning asset management processes and practices with AS ISO55000:2014<sup>1</sup> to ensure a consistent approach is applied throughout the life cycle of assets.

<sup>1</sup> AS ISO 55000:2014 is an international Asset Management standard.

### Phase 3 – Resource alignment

*Ensuring resources are made available to achieve strategies which are to be implemented and that resourcing needs are taken into account in the development of asset management strategies.*

Powerlink uses a range of tools to develop resource plans over medium to long-term forward planning horizons.

### Phase 4 – Continuous review

*Monitoring and reviewing network, asset and business performance outcomes continuously.*

Powerlink focuses on:

- reviewing the implementation of strategies to identify and adopt improvements
- checking strategies deliver to Powerlink’s obligations and the expectations of customers.

**Figure 4.3** Asset management cycle



## 4.5 Asset management methodologies

Powerlink’s asset management methodologies are fundamental in supporting the appraisal of future reinvestment needs, particularly in relation to:

- the monitoring and analysis of asset health, condition and performance
- identifying the emerging needs for asset intervention to enable considered and prudent decision making
- consideration of all economic and technically feasible options (including non-network options)
- assessment of benefits, risks and costs
- whole of life cycle planning.

Reinvestment in assets approaching the end of their economic and technical life forms a substantial part of Powerlink’s future network investment plans across the 10-year outlook period. Accordingly the assessment of risk associated with the condition and performance of these assets is of particular importance. In order to inform such risk assessments, Powerlink undertakes periodic reviews of network assets which considers a broad range of factors, including physical condition, capacity constraints, performance and functionality, statutory compliance and ongoing supportability.

## 4 Asset management overview

Risk assessments are underpinned by Powerlink's corporate risk management framework and the application of a range of risk assessment methodologies set out in AS/NZS ISO31000:2018 Risk Management Guidelines<sup>2</sup>.

### 4.6 Flexible and integrated network investment planning

A fundamental element of the Asset Management System involves the adoption of processes to manage the life cycle of assets, from planning and investment to operation, maintenance and refurbishment, to end of technical service life.

A range of options are considered as part of a flexible and integrated approach to network investment planning. These options may include retiring or decommissioning assets where there is unlikely to be an ongoing future need, refurbishing to maintain the service life of assets, replacing assets of different capacity or type, alternate network configuration opportunities, and non-network solutions.

The purpose of Powerlink's network investment planning is to:

- apply the principles set out in Powerlink's Asset Management Policy, Asset Management Strategy and related processes to guide network asset planning and reinvestment decisions;
- provide an overview of asset condition and health, life cycle plans and emerging risks related to factors such as safety, network reliability, resilience and obsolescence;
- provide an overview and analysis of factors that impact network development, including energy and demand forecasts, generation developments, forecast network performance and capability, and the condition and performance of Powerlink's existing asset base;
- identify potential opportunities for optimisation of the transmission network; and
- provide the platform to enable the transition to a more sustainable, cost efficient and climate resilient energy system.

### 4.7 Asset management implementation

Powerlink has adopted implementation strategies across its portfolio of projects and maintenance activities aimed at efficiently delivering the overall work program including prudent design standardisation by considering emerging trends in technology, portfolio management and supply chain management.

One of Powerlink's objectives includes the efficient implementation of work associated with network operation, field maintenance and project delivery. Powerlink continues to pursue innovative work techniques that:

- reduce risk to personal safety;
- optimise maintenance and/or operating costs; and
- reduce the requirement and minimise the impacts of planned outages on the transmission network.

In line with good practice, Powerlink also undertakes regular auditing of work performed to facilitate the continuous improvement of the overall Asset Management System.

### 4.8 Further information

Further information on Powerlink's Asset Management System may be obtained by emailing [networkassessments@powerlink.com.au](mailto:networkassessments@powerlink.com.au).

---

<sup>2</sup> [AS/NZS ISO 31000:2018](#) is an international Risk Management standard.

## **CHAPTER 5**

# Future network development

- 5.1 Introduction
- 5.2 Integrated System Plan alignment
- 5.3 Flexible and integrated approach to network development
- 5.4 Forecast capital expenditure
- 5.5 Forecast network limitations
- 5.6 Consultations
- 5.7 Proposed network developments



# 5 Future network development

## Key highlights

- Powerlink continues to adapt and respond to shifts in an increasingly uncertain operating environment, which has been further impacted by the restrictions of the COVID-19 pandemic.
- To deliver positive outcomes for customers, Powerlink applies a flexible and integrated approach to efficient investment decision making taking into consideration multiple factors including:
  - assessing whether an enduring need exists for assets and investigating alternate network configuration opportunities and/or non-network solutions, where feasible, to manage asset risks
  - assessing dynamic changes in Powerlink's operating environment to ensure network resilience
  - actively seeking opportunities to implement more cost effective prudent solutions whenever possible, such as transmission line refits, that avoid or delay the need to establish new transmission network infrastructure.
- The changing generation mix may lead to increased constraints across critical grid sections. Powerlink will consider these potential constraints holistically as part of the planning process and in conjunction with the findings of the most recent Integrated System Plan (ISP).
- Powerlink has identified a need for additional reactive support to manage high voltages associated with light load conditions in central and south-east Queensland in the five-year outlook period.
- As recommended by the 2018 ISP and since the publication of the 2019 Transmission Annual Planning Report, (TAPR) Powerlink and TransGrid concluded a Regulatory Investment Test for Transmission (RIT-T) to assess the market benefits of expanding the New South Wales (NSW)-Queensland transmission transfer capacity. The resulting transmission network project will support more efficient generation sharing between NSW and Queensland and improve the overall reliability of the transmission system by 2022.

## 5.1 Introduction

Powerlink Queensland as a Transmission Network Service Provider (TNSP) in the National Electricity Market (NEM) and as the appointed Jurisdictional Planning Body (JPB) by the Queensland Government is responsible for transmission network planning for the national grid within Queensland. Powerlink's obligation is to plan the transmission system to reliably and economically supply load while managing risks associated with the condition and performance of existing assets in accordance with the requirements of the National Electricity Rules (NER), Queensland's Electricity Act 1994 (the Act) and its Transmission Authority.

The NER (Clause 5.12.2(c)(3)) requires the TAPR to provide 'a forecast of constraints and inability to meet the network performance requirements set out in schedule 5.1 or relevant legislation or regulations of a participating jurisdiction over one, three and five years'. In addition, there is a requirement (Clause 5.12.2(c)(4)) to provide estimated load reductions that would defer forecast limitations for a period of 12 months and to state any intent to issue request for proposals for augmentation, replacement of network assets or non-network alternatives. The NER (Clause 5.12.2(c)) also requires the TAPR to be consistent with the TAPR Guidelines and include information pertinent to all proposed:

- augmentations to the network (Clause 5.12.2(c)(5))
- replacements of network assets (Clause 5.12.2(c)(5))
- network asset retirements or asset de-ratings that would result in a network constraint in the 10-year outlook period (Clause 5.12.2(c) (1A)).

This chapter on proposed future network developments contains:

- discussion on Powerlink's integrated planning approach to network development
- information regarding assets reaching the end of their service life and options to address the risks arising from ageing assets remaining in-service, including asset reinvestment, non-network solutions, potential network reconfigurations, asset retirements or de-ratings

- identification of emerging future limitations<sup>1</sup> with potential to affect supply reliability including estimated load reductions required to defer these forecast limitations by 12 months (Clause 5.12.2(c)(4)(iii))
- a statement of intent to issue request for proposals for augmentation, the proposed replacement of ageing network assets or non-network alternatives identified as part of the annual planning review (Clause 5.12.2(c)(4)(iv))
- a summary of network limitations over the next five years (Clause 5.12.2.(c)(3))
- details in relation to the need to address the risks arising from ageing network assets remaining in-service and those limitations for which Powerlink intends to address or initiate consultation with market participants and interested parties
- the manner in which proposed augmentations and the replacement of network assets relate to the Australian Energy Market Operator (AEMO)'s most recent ISP (Clause 5.12.2.(c)(6)) and
- a Table summarising possible connection point proposals.

Where appropriate all transmission network, distribution network or non-network (either demand management or local generation) alternatives are considered as options for investment or reinvestment. Submissions for non-network alternatives are invited by contacting [networkassessments@powerlink.com.au](mailto:networkassessments@powerlink.com.au).

## 5.2 ISP alignment

The 2020 ISP published by AEMO in July (which incorporates components of the superseded National Transmission Network Development Plan) provides an independent, strategic view of the efficient development of the NEM transmission network over a 20-year planning horizon.

Powerlink will proactively monitor the changing outlook for the Queensland region and take into consideration the impact of emerging technologies, withdrawal of gas and coal-fired generation and the integration of variable renewable energy (VRE) generation in future transmission plans. These plans may include:

- reinvesting in assets to extend their end of technical service life
- removing some assets without replacement
- determining optimal sections of the network for new connection (in particular renewable generation) as discussed in detail in Chapter 8 and where applicable, in conjunction with the ISP
- replacing existing assets with assets of a different type, configuration or capacity
- investing in assets to maintain planning standards, including Powerlink's obligations for system strength and voltage control
- non-network solutions.

<sup>1</sup> Identification of forecast limitations in this chapter does not mean that there is an imminent supply reliability risk. The NER requires identification of limitations which are expected to occur some years into the future, assuming that demand for electricity is consistent with the forecast in this TAPR.

# 5 Future network development

## 5.3 Flexible and integrated approach to network development

Powerlink’s planning for future network development will focus on pursuing flexible solutions which can adapt to the changing environment. This will deliver positive outcomes for customers while ensuring the ongoing safe and reliable supply of electricity and may include optimising the network topography based on the analysis of future network needs due to:

- forecast demand
- new customer access requirements (including possible Renewable Energy Zones (REZ))
- potential power system development pathways signalled in the ISP
- anomalies in Powerlink’s operating environment or changes in technical characteristics (e.g. minimum demand, system strength, voltage limitations) during the transition to more VRE generation
- existing network configuration
- safety, condition and compliance based risks related to existing assets.

This planning process includes consideration of a broad range of options to address identified needs described in Table 5.1. Irrespective of the option or range of options used to address an identified need, where Powerlink identifies that there is a credible option greater than \$6 million, Powerlink is required to undertake a RIT-T. The RIT-T describes the need, the credible options identified and provides the requirements for non-network alternatives.

**Table 5.1** Examples of planning options

Option	Description
Augmentation	Increases the capacity of the existing transmission network, e.g. the establishment of a new substation, installation of additional plant at existing substations or construction of new transmission lines. This is driven by the need to meet prevailing network limitations and customer supply requirements.
System services	The assessment of future network requirements to meet overall power system performance standards and support the secure operation of the power system. This includes the provision of system strength services and inertia services.
Reinvestment	Asset reinvestment planning ensures that existing network assets are assessed for their enduring network requirements in a manner that is economic, safe and reliable. This may result in like-for-like replacement, network reconfiguration, asset retirement, line refit or replacement with an asset of lower capacity. Condition and risk assessment of individual components may also result in the staged replacement of an asset where it is technically and economically feasible.
Network reconfiguration	The assessment of future network requirements may identify the reconfiguration of existing assets as the most economical option. This may involve asset retirement coupled with the installation of plant or equipment at an alternative location that offers a lower cost substitute for the required network functionality.
Asset de-rating or retirement	May include strategies to de-rate, decommission and/or demolish an asset and is considered in cases where needs have diminished in order to achieve long-term economic benefits.
Line refit	Powerlink utilises a line reinvestment strategy called line refit to extend the service life of a transmission line and provide cost benefits through the deferral of future transmission line rebuilds. Line refit may include structural repairs, foundation works, replacement of line components and hardware and the abrasive blasting of tower steelwork followed by painting.
Non-network alternatives	Non-network solutions are not limited to, but may include network support from existing and/or new generation or demand side management (DSM) initiatives (either from individual providers or aggregators) which may reduce, negate or defer the need for network investment solutions.
Operational measures	Network constraints may be managed during specific periods using short-term operational measures, e.g. switching of transmission lines or redispatch of generation in order to defer or negate network investment.

## 5.4 Forecast capital expenditure

The energy industry is going through a period of transformation driven by shifts in economic outlook, customer behaviour, government policy and regulation and emerging technologies that have reshaped the environment in which Powerlink delivers its transmission services. This has been further impacted by the COVID-19 pandemic.

In this changed environment, Powerlink is focussing on assessing the enduring need for key ageing assets that are approaching the end of their service life, and maintaining network resilience. Powerlink is also seeking alternative investment options through network reconfiguration to manage asset condition and/or non-network solutions where economic and technically feasible.

Powerlink has a focussed and strategic approach in determining when it is appropriate to refit or replace ageing transmission assets and how to implement these works cost effectively, such as targeted asset replacement or staged works that avoid or delay the need to establish new transmission network infrastructure. This approach is aimed at delivering positive outcomes for customers.

The 10-year outlook period discussed in the 2020 TAPR runs from 2020/21 to 2030/31 and traverses both the 2017-22 and 2023-27 regulatory periods and beyond.

## 5.5 Forecast network limitations

As outlined in Section 1.7.1, under its Transmission Authority, Powerlink must plan and develop its network so that it can supply the forecast maximum demand with the system intact. The planning standard, which came into effect from July 2014, permits Powerlink to plan and develop the network on the basis that some load may be interrupted during a single network contingency event. Forward planning allows Powerlink adequate time to identify emerging limitations and to implement appropriate network and/or non-network solutions to maintain transmission services which meet the planning standard.

Emerging limitations may be triggered by thermal plant ratings (including fault current ratings), protection relay load limits, voltage stability and/or transient stability. Appendix E lists the indicative maximum short circuit currents and fault rating of the lowest rated plant at each Powerlink substation and voltage level, accounting for committed projects listed in Chapter 9 and existing and committed generation listed in Chapter 6.

Based on AEMO's Central scenario forecast discussed in Chapter 2, the maximum demand for electricity remains relatively flat in the next five years. Powerlink does not anticipate undertaking any significant augmentation works during this period based on load growth alone. However, the changing generation mix may lead to increased constraints across critical grid sections. Powerlink will consider these potential constraints holistically with the emerging condition based drivers as part of the planning process and in conjunction with the 2020 ISP.

In [Powerlink's Revenue Determination 2017-2022](#)<sup>2</sup>, projects that could be triggered by the commitment of large mining or industrial block loads were identified as contingent projects. Contingent projects and their triggers are discussed in detail in sections 7.3 and 7.4.

In accordance with the NER, Powerlink undertakes consultations with AEMO, Registered Participants and interested parties on feasible solutions to address forecast network limitations through the RIT-T process. Solutions may include provision of network support from existing and/or new generators, DSM initiatives (either from individual providers or aggregators) and network augmentations.

---

<sup>2</sup> Information on Powerlink's Revenue Proposal for the 2023-2027 regulatory period is available on [Powerlink's website](#).

## 5 Future network development

### 5.5.1 Summary of forecast network limitations within the next five years

Powerlink has identified that due to declining minimum demand and increasing penetration of VRE generation, there is an emerging need for additional reactive plant in various zones in Queensland to manage potential over-voltages, and meet system strength requirements. Table 5.2<sup>3</sup> summarises limitations identified in the Powerlink's transmission network which are discussed in sections 5.7.4 and 5.7.10 and noted in AEMO's Network Support and Control Ancillary Services (NSCAS) Report published in December 2019.

**Table 5.2:** Limitations in the five-year outlook period

Limitation	Zone	Reason for anticipated limitation	Time limitation may be reached			Reference
			1-year outlook (2020/21)	3-year outlook (up to 2023/24)	5-year outlook (up to 2025/26)	
System Strength Services in Queensland to address Fault Level Shortfall at Ross (I)	Far North	AEMO declared system strength shortfall April 2020		Immediate shortfall with services required to be in place by 31 August 2021		<a href="#">Section 5.7.1</a>
Managing voltages in Queensland	Central West			2020/21 (I)		<a href="#">Section 5.7.4</a>
	Moreton			2022/23		<a href="#">Section 5.7.10</a>

Note:

(I) The network risk associated with this limitation is currently being managed through a range of short-term operational measures until such time as the most economic long-term solution can be implemented.

Based on AEMO's Central scenario forecast discussed in Chapter 2 there are no other network limitations forecast to occur in Queensland in the next five years<sup>4</sup>.

### 5.5.2 Summary of forecast network limitations beyond five years

The timing of forecast network limitations may be influenced by a number of factors such as load growth, industrial developments, new and retiring generation, the planning standard and joint planning with other Network Service Providers (NSP). As a result, it is possible for the timing of forecast network limitations identified in a previous year's TAPR to shift beyond the previously identified timing. However, there were no forecast network limitations identified in Powerlink's transmission network in the 2019 TAPR which fall into this category in 2020.

## 5.6 Consultations

Network development to meet forecast demand is dependent on the location and capacity of generation developments and the pattern of generation dispatch in the competitive electricity market. Uncertainty about the generation pattern creates uncertainty about the power flows on the network and subsequently, which parts of the network will experience limitations. This uncertainty is a feature of the competitive electricity market and historically has been particularly evident in the Queensland region. Notwithstanding the discussion in sections 5.7.6 and 7.2, Powerlink has not anticipated any material changes to network power flows which may require any major augmentation driven network development. This is due to a combination of several factors including a relatively flat maximum demand forecast in the 10-year outlook period and Powerlink's planning criteria (refer to chapters 1 and 2).

<sup>3</sup> Refer to NER Clause 5.12.2(c)(3).

<sup>4</sup> Refer to NER Clause 5.12.2(c)(3).

Proposals for transmission investments and reinvestments over \$6 million are progressed under the provisions of Clause 5.16.4 (not actionable ISP projects) and 5.16A (actionable ISP projects) of the NER. In particular, for projects which are not actionable ISP projects, and where action is considered necessary, Powerlink will:

- notify of anticipated limitations or risks arising from ageing network assets remaining in-service within the timeframe required for action
- seek input, initially via the TAPR, on potential solutions to network limitations which may result in transmission network or non-network investments in the 10-year outlook period
- issue detailed information outlining emerging network limitations or the risks arising from ageing network assets remaining in-service to assist non-network solutions as possible genuine alternatives to network investments to be identified
- consult with AEMO, Registered Participants and interested parties on credible options (network or non-network) to address emerging limitations or the risks arising from ageing network assets remaining in-service
- carry out detailed analysis on credible options that Powerlink may propose to address identified network limitations or the risks arising from ageing network assets remaining in-service
- consult with AEMO, Registered Participants and interested parties on all credible options (network and non-network) and the preferred option
- implement the preferred option in the event an investment (network and/or non-network) is found to satisfy the RIT-T.

Alternatively, transmission investments may be undertaken under the 'funded augmentation' provisions of the NER.

It should be noted that the information provided regarding Powerlink's network development plans may change and should be confirmed with Powerlink before any action is taken based on the information contained in this TAPR or the accompanying TAPR templates<sup>5</sup>.

### 5.6.1 Current consultations – proposed transmission investments

Commencing August 2010 proposals for transmission investments over \$6 million addressing network limitations (augmentation works) are progressed under the provisions of Clause 5.16.4 of the NER. In September 2017 this NER requirement, i.e. to undertake a RIT-T, was extended<sup>6</sup> to include the proposed replacement of network assets. More recently, from 1 July 2020 a [new process](#) is in place for projects which have been identified in AEMO's ISP as actionable ISP projects (Clause 5.16A).<sup>7</sup>

Powerlink carries out separate consultation processes for each proposed new transmission investment or reinvestment over \$6 million by utilising the applicable RIT-T consultation process. The majority of Regulatory Investment Test for Transmission (RIT-T) consultations undertaken by Powerlink relate to projects which are not actionable ISP projects (refer to Figure 5.1).

<sup>5</sup> In accordance with the [AER's TAPR Guidelines](#) published in December 2018.

<sup>6</sup> [Replacement expenditure planning arrangements](#) Rule 2017 No. 5.

<sup>7</sup> [National Electricity Amendment ISP Rule 2020](#).

# 5 Future network development

**Figure 5.1** Overview of the RIT-T consultation process for projects which are not actionable ISP projects

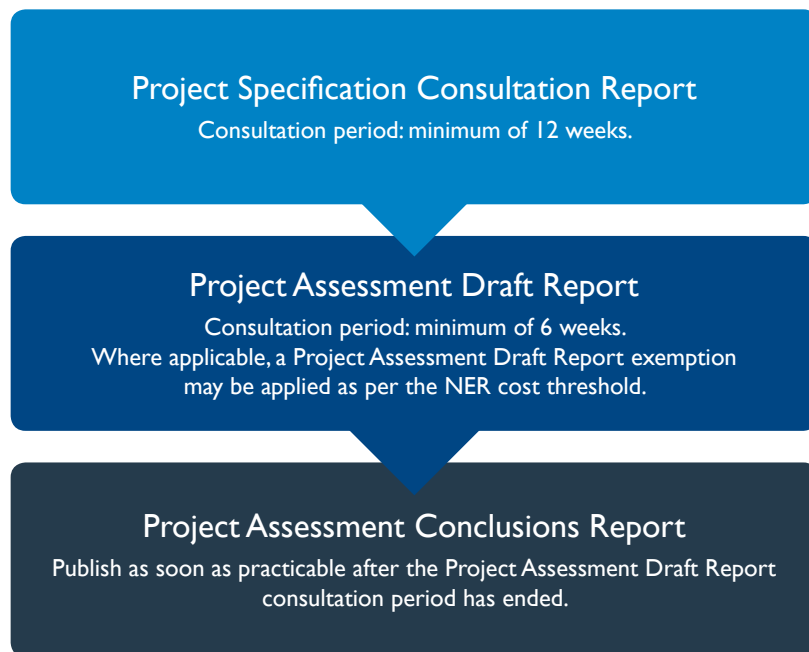

The consultations completed since publication of the 2019 TAPR are listed in Table 5.3 (refer to Chapter 9). Nine of the 10 RIT-Ts completed were in relation to reinvestments in Powerlink’s transmission network

**Table 5.3:** RIT-T consultations completed since publication of the 2019 TAPR

Consultation
Maintaining reliability of supply at Kamerunga Substation
Addressing the secondary systems condition risks at Cairns
Maintaining reliability of supply between Clare South and Townsville South
Maintaining power transfer capability and reliability of supply at Lilyvale
Addressing the secondary systems condition risks in the Gladstone South area
Maintaining reliability of supply in the Blackwater area
Addressing the secondary systems condition risks at Kemmis
Addressing the secondary systems condition risks at Mudgeeraba
Addressing the secondary systems condition risks at Mt England
Expanding NSW-Queensland transmission transfer capacity (in conjunction with TransGrid)

There are no RIT-T consultations under way as at 30 September 2020.

Other consultations (non RIT-T) currently under way are listed in Table 5.4.

**Table 5.4:** Other consultations currently under way

Consultation	Reference
Request for system strength services in Queensland to address fault level shortfall at Ross	<a href="#">Section 5.7.1</a>

Registered Participants and interested parties are referred to the consultation documents which are published and made available on [Powerlink's website](#) for further information.

## 5.6.2 Future consultations – proposed transmission investments

### Anticipated consultations

Reinvestment in the transmission network to manage the risks arising from ageing assets remaining in-service will form the majority of Powerlink's capital expenditure program of work moving forward. These emerging risks over the 10-year outlook period are discussed in Section 5.7. Table 5.5 summarises consultations Powerlink anticipates undertaking within the next 12 months under the Australian Energy Regulator's (AER) RIT-T to address either the proposed reinvestment in a network asset or limitation.

**Table 5.5:** Anticipated consultations in the forthcoming 12 months (to October 2021) (1)

Consultation	Reference
Maintaining reliability of supply in the Cairns area	<a href="#">Section 5.7.1</a>
Addressing the secondary systems condition risks at Innisfail	<a href="#">Section 5.7.1</a>
Managing CQ voltages	<a href="#">Section 5.7.4</a>
Maintaining reliability of supply to Gladstone South	<a href="#">Section 5.7.5</a>
Maintaining reliability of supply in the Gladstone region	<a href="#">Section 5.7.5</a>
Maintaining reliability of supply between central and southern Queensland	<a href="#">Section 5.7.6</a>
Maintaining reliability of supply in the Tarong and Chinchilla areas	<a href="#">Section 5.7.7</a>
Addressing the secondary systems condition risks at Murarrie	<a href="#">Section 5.7.10</a>
Managing power transfer capability and reliability of supply at Redbank Plains	<a href="#">Section 5.7.10</a>

Note:

(1) The anticipated consultations listed in Table 5.5 reflect the RIT-T status as at 30 September 2020.



# 5 Future network development

## 5.6.3 Connection point proposals

Planning of new or augmented connections involves consultation between Powerlink and the connecting party, determination of technical requirements and completion of connection agreements. New connections can result from joint planning with the relevant Distribution Network Service Provider (DNSP)<sup>8</sup> or be initiated by generators or customers.

Table 5.6 lists possible connection works that may be required within the 10-year outlook period.

**Table 5.6** Connection point proposals

Connection point name	Proposal	Zone
Moura Solar Farm	New solar farm	Central West
Rodds Bay Solar Farm	New solar farm	Gladstone
Woolooga Energy Park Solar Farm	New solar farm	Wide Bay
Bluegrass Solar Farm	New solar farm	Surat
Columboola Solar Farm	New solar farm	Surat
Western Downs Green Power Hub Solar Farm	New solar farm	Bulli

Note:

When Powerlink constructs a new line or substation as a non-regulated customer connection (e.g. conventional generator, renewable generator, mine or industrial development), the costs of acquiring easements, constructing and operating the transmission line and/or substation are paid for by the company making the connection request.

Table 5.6 lists the projects that are in the public domain, either as approved or through publication by the proponents. Powerlink does not include projects that are not public.

Table 5.7 summarises connection point activities<sup>9</sup> undertaken by Powerlink since publication of the 2019 TAPR. Additional details on potential new generation connections are available in the relevant TAPR template located on Powerlink's website as noted in Appendix B.

**Table 5.7** Connection point activities

Generator Location	Number of Applications	Generator Type and Technology
North	3	Solar, Pumped Storage Hydro & Wind
Central	4	Solar, Wind
South	7	Solar, Wind & Storage
Total	14	

## 5.7 Proposed network developments

As the Queensland transmission network experienced considerable growth in the period from 1960 to 1980, there are now many transmission assets between 40 and 60 years old. It has been identified that a number of these assets are approaching the end of their technical service life and reinvestment in some form is required within the 10-year outlook period in order to manage emerging risks related to safety, reliability and other factors. Moving forward, Powerlink's capital expenditure program of work focuses on reinvestment in the transmission network to manage the identified risks arising from the condition of these ageing assets.

<sup>8</sup> In Queensland, Energex and Ergon Energy (part of the Energy Queensland Group) are the DNSPs.

<sup>9</sup> More broadly, key connection information in relation to the NEM can be found on [AEMO](#) website.

In conjunction with condition assessments and risk identification, as assets approach their anticipated end of technical service life, possible reinvestment options undergo detailed planning studies to confirm alignment with future reinvestment, optimisation and delivery strategies. These studies have the potential to provide Powerlink with an opportunity to:

- improve and further refine options under consideration
- consider other options from those originally identified which may deliver a greater benefit to customers.

Information regarding possible reinvestment alternatives and anticipated timing is updated annually within the TAPR and includes discussion on significant changes which have occurred since publication of the previous year's TAPR together with the latest information available at the time.

Where applicable, in relation to proposed expenditure for the replacement of network assets or network augmentations, Powerlink will consult with AEMO, Registered Participants and interested parties on feasible solutions identified through the RIT-T. The latest information on RIT-T publications can be found on [Powerlink's website](#).

Proposed network developments discussed within this chapter identify the most likely network solution, although as mentioned, this has the potential to change with ongoing detailed analysis of asset condition and risks, network requirements or as a result of RIT-T consultations.

Other than the emerging high voltage conditions discussed in the 2019 NSCAS Report<sup>10</sup> and based on the current information available, Powerlink considers all of the possible network developments discussed in this chapter are outside of the scope of the most recent ISP, NSCAS Report and Power System Frequency Risk Review (PSFRR)<sup>11</sup>. The Final 2020 ISP released in July identified three future ISP projects – Queensland/New South Wales Interconnector (QNI), Medium and Large interconnector upgrades, Central to Southern Queensland Transmission Link and Gladstone Grid Reinforcements. Powerlink will provide the necessary preparatory activities by 30 June 2021 to inform the development of the 2022 ISP. These projects are discussed further in Section 7.4.

Powerlink also reviews the rating of assets throughout the transmission network periodically and has not identified any required asset de-ratings that would result in a system limitation as part of the 2020 annual planning review<sup>12</sup>.

An analysis of reinvestment needs and potential limitations has been performed across Powerlink's standard geographic zones (refer to sections 5.7.1 to 5.7.11). For clarity, possible network reinvestments have been separated into two periods.

#### **Possible network reinvestments within five years**

This includes the financial period from 2020/21 to 2025/26 for possible near term reinvestments when:

- confirmation of the enduring network need and timing occurs
- detailed planning studies are underway or have recently been finalised.

#### **Possible network reinvestments within six to 10 years**

This includes the financial period from 2026/27 to 2030/31, for possible medium to long-term reinvestments. Powerlink takes a balanced, prudent and proportionate approach to the consideration of reinvestment needs to address the risks arising from network assets in the medium to long-term and undertakes detailed planning analysis and condition assessment closer to the possible reinvestment date, typically within five years.

<sup>10</sup> AEMO's [2019 NSCAS Report](#) December 2019, page 9.

<sup>11</sup> NER Clauses 5.12.2(6) and (6A).

<sup>12</sup> NER Clause 5.12.2(c)(1A).

## 5 Future network development

In addition, due to the current dynamic operating environment, there is less certainty regarding the needs or drivers for reinvestments in these later years of the annual planning review period. As a result, considerations in this period have a greater potential to change when compared to near term investments. Possible reinvestment considerations within six to 10 years will need to be flexible in order to adapt to externally driven changes as the NEM evolves and customer behaviours change. Any significant adjustments which may occur as a result of changes will be updated and discussed in subsequent TAPRs.

Powerlink also takes a value-driven approach to the management of asset risks to ensure an appropriate balance between reliability and the cost of transmission services which ultimately benefits customers. Each year, taking the most recent assessment of asset condition and risk into consideration, Powerlink reviews possible commissioning dates and where safe, technically feasible and prudent, capital expenditure is delayed. As a result, there may be timing variances between the possible commissioning dates identified in the 2019 TAPR and 2020 TAPR and TAPR Templates. Significant timing differences are noted in the analysis of the program of work within this chapter (refer to sections 5.7.1 to 5.7.11).

The functions performed by the major transmission network assets discussed in this chapter and which form the majority of Powerlink's capital expenditure in the 10-year outlook period are illustrated in Figure 5.2.

Figure 5.2 The functions of major transmission assets

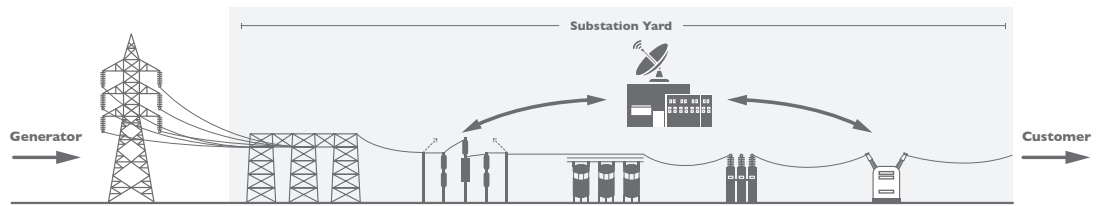

### Transmission line

A transmission line consists of tower structures, high voltage conductors and insulators and transports bulk electricity via substations to distribution points that operate at lower voltages.



### Substation

A substation, which is made up of primary plant, secondary systems, telecommunications equipment and buildings, connects two or more transmission lines to the transmission network and usually includes at least one transformer at the site.

A substation that connects to transmission lines, but does not include a transformer, is known as a switching station.



- **Substation bay**

A substation bay connects and disconnects network assets during faults and also allows maintenance and repairs to occur. A typical substation bay is made up of a circuit breaker (opened to disconnect a network element), isolators and earth switches (to ensure that maintenance and repairs can be carried out safely), and equipment to monitor and control the bay components.



- **Static VAR Compensator (SVC)**

A SVC is used where needed, to smooth voltage fluctuations, which may occur from time-to-time on the transmission network. This enables more power to be transferred on the transmission network and also assists in the control of voltage.



- **Capacitor Bank**

A capacitor bank maintains voltage levels by improving the 'power factor'. This enables more power to be transferred on the transmission network.



- **Transformer**

A transformer is used to change the voltage of the electricity flowing on the network. At the generation connection point, the voltage is 'stepped up' to transport higher levels of electricity at a higher voltage, usually 132kV or 275kV, along the transmission network. Typically at a distribution point, the voltage is 'stepped down' to allow the transfer of electricity to the distribution system, which operates at a lower voltage than the transmission network.



- **Bus reactor**

A bus reactor is used to control voltages on the high voltage system. Bus reactors are used especially during light load conditions to manage high voltages which may occur on the network.



### Secondary systems

Secondary systems equipment assists in the control, protection and safe operation of transmission assets that transfer electricity in the transmission network.



### Telecommunication systems

Telecommunication systems are used to transfer a variety of data about the operation and security of the transmission network including metering data for AEMO.

# 5 Future network development

## 5.7.1 Far North zone

### Existing network

The Far North zone is supplied by a 275kV transmission network with major injection points at the Chalumbin and Woree, and a coastal 132kV network from Yabulu South to Tully to Woree. This network supplies the Energy Queensland distribution network feeding the surrounding areas of Turkinje and Cairns, from Tully to Cooktown. The network also connects various renewable generators including the hydro power stations at Barron Gorge and Kareeya, and Mt Emerald Wind Farm near Walkamin (refer to Figure 5.3).

Figure 5.3 Far North zone transmission network

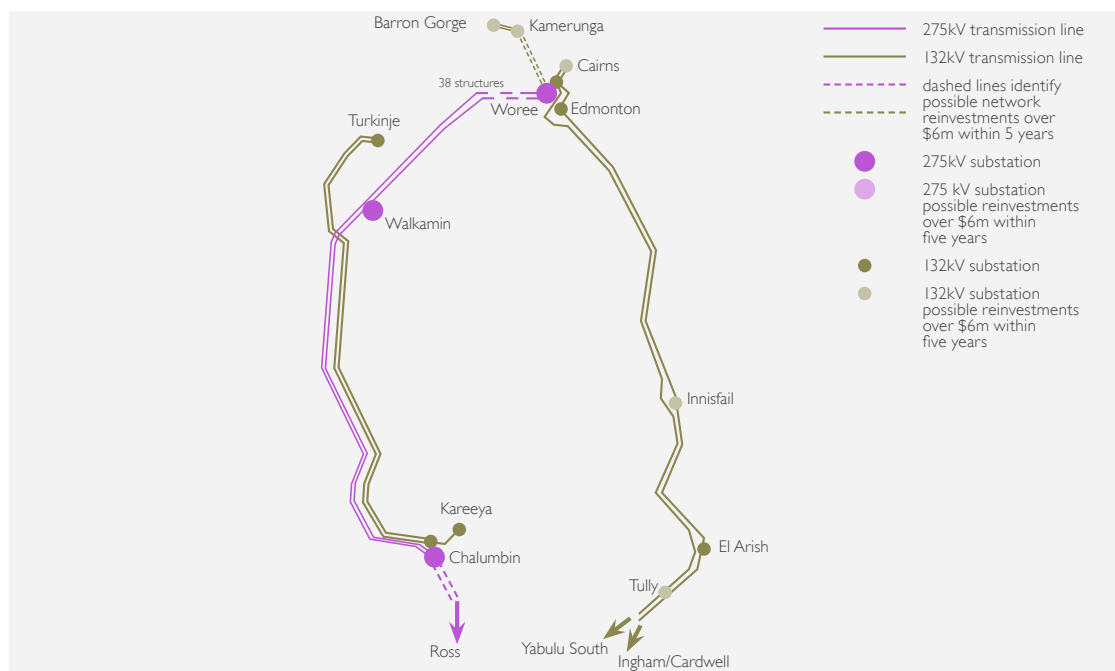

### Possible load driven limitations

Based on AEMO's Central scenario forecast discussed in Chapter 2, there is no additional capacity forecast to be required as a result of network limitations in the Far North zone within the next five years to meet reliability obligations.

### Possible network investments to address non-load driven network constraints in the next five years

#### Current Expression of interest (EOI): System strength services in Queensland to address fault level shortfall at Ross

During April 2020, AEMO issued a formal Notice of a fault level shortfall of 90MVA at the Ross 275kV fault level node, the most northern fault level node located in Queensland<sup>13</sup>. The Notice requires Powerlink to address this shortfall by 31 August 2021. With the agreement of AEMO and in accordance with Clause 5.20C.3 of the NER, Powerlink issued a Request for system strength services in April 2020 seeking expressions of interest (EOI) from market participants for offers for system strength remediation services.

However, fault current is only an attribute of system strength and the stability issue being observed is located further north in the transmission network near Cairns. To enable interested parties to understand the nature of the stability problem and to better inform submissions, Powerlink published a clarification document in April 2020.

<sup>13</sup> Under the NER, system strength is measured by fault level at designated fault level nodes (Clause 5.20C.1(b)).

Powerlink received a very positive response to the EOI offering a range of system strength support services to address the fault level shortfall at Ross and have been working closely with the AEMO on the proposed remediation approach. AEMO has now approved the approach for the short-term, up until the end of December 2020. As a result, Powerlink has entered into a short-term agreement with CleanCo Queensland to provide system strength services through utilising its assets in Far North Queensland (FNQ).

In addition, during August 2020 AEMO provided preliminary confirmation that, subject to the final exchange of modelling and other details, inverter tuning could reduce the overall system strength requirement at Ross. Consequently Powerlink has entered into an agreement with Daydream, Hamilton, Hayman and Whitsunday Solar Farms in NQ to validate the expected positive benefits of inverter tuning during the daytime.

Powerlink will continue to work closely with proponents of non-network solutions and AEMO to develop more complete and technically feasible short and long-term solutions to the System Strength Shortfall and undertake the relevant formal approval process in accordance with the NER when the optimal solution has been identified. Powerlink will also discuss the outcome in the 2021 TAPR in accordance with clauses 5.20C.3(f) and (g) of the NER.

#### **Possible network reinvestments within five years**

Network reinvestments in Far North zone are related to addressing the risks arising from the condition of the existing network assets, which without corrective action, would result in Powerlink being exposed to breaching a number of its jurisdictional network, safety, environmental and Rules' obligations.

By addressing the condition of these existing assets, Powerlink is seeking to ensure it can deliver a safe, cost effective and reliable supply of electricity to meet the load requirements of customers in the Far North zone into the future. This may result in like-for-like replacement, non-network solutions, network reconfiguration, asset retirement, line refit or replacement with an asset of lower capacity.

#### **Transmission lines**

##### **Woree to Kamerunga 132kV transmission lines**

##### *Potential consultation: Maintaining reliability of supply to Cairns northern beaches area*

The Woree to Kamerunga 132kV double circuit transmission lines were constructed in 1963. Originally connected to Cairns, it provides critical supply to the Cairns northern beaches region, as well as connecting the Barron Gorge Hydro Power Station to the backbone 275kV network.

#### **Project driver:**

Emerging conditions risks due to structural corrosion.

In 2014 life extension works were performed on certain components of this transmission line that were nearing the end of their operational life. However, it is anticipated that reinvestment will again be required by 2026. The location of the existing structures poses access and construction work challenges. A possible end of technical service life strategy for this transmission line is replacement on a new easement. Investigations for easement alternatives are currently underway.

#### **Project timing: December 2026**

#### **Possible network solutions**

- Maintaining the existing 132kV network topography through a new double circuit transmission line from Woree and Kamerunga substations by December 2026
- Network reconfiguration by establishing two single circuit 132kV transmission lines between Woree to Kamerunga substations, or via Cairns North substation, by December 2026.

*Proposed network solution: Maintaining 132kV network topology through a new double circuit transmission line on a new easement from Woree to Kamerunga substations at an estimated cost of \$40 million<sup>14</sup>, by December 2026.*

Powerlink considers the proposed network solution will not have a material inter-network impact.

<sup>14</sup> This excludes easement costs yet to be determined.

# 5 Future network development

## Possible non-network solutions

Potential non-network solutions would need to provide supply to the 22kV network of up to a peak 70MW, and up to a peak 1200MWh per day on a continuous basis. It should be noted that this transmission line also facilitates generation connection in the area.

## Ross to Chalumbin to Woree 275kV transmission lines

### *Anticipated consultation: Maintaining reliability of supply in the Cairns region*

The majority of electricity used in the Cairns region is transported from central and north Queensland on Powerlink's 275kV system to Ross, near Townsville. From Ross it is transferred via a double circuit 275kV transmission line to Chalumbin, then via a double circuit transmission line, between Chalumbin and the Woree Substation on the outskirts of Cairns. These 275kV transmission lines also provide supply to Turkinje, and connection to the Mt Emerald Wind Farm and Kareeya Hydro Power Station. Additional connections are made through the parallel 132kV transmission network that provides supply to the coastal communities between Townsville and Cairns.

The double circuit 275kV transmission line between Ross and Chalumbin substations is 244km in length and comprises 528 steel lattice towers. The line was commissioned in 1989 and traverses the rugged terrain of the NQ tropical rain forest, passing through environmentally sensitive, protected areas and crossing numerous regional roads and rivers. Those sections of the line that are elevated and bordering on the Wet Tropics are exhibiting higher levels of atmospheric corrosion than sections in the more protected or dryer areas.

Non-homogeneity of the line condition presents a cost effective opportunity for a staggered refit intervention addressing towers in the different condition with different levels of refit intensity. Subject to the outcome of a RIT-T, this approach is anticipated to deliver the most economic outcome for customers while providing a uniform end of life for all towers on the line.

The Chalumbin to Woree section of line was built in 1998 and is approximately 140km in length. While the condition of a large majority of the line is consistent with its age, this is not the case for the final 16km into Cairns between Davies Creek and Bayview Heights. This final section contains 32 towers that traverse the environmentally sensitive World Heritage Wet Tropics area and terminates near Trinity Inlet Marine Park. These towers have been designed to allow over spanning to minimise corridor clearing. However the extended height has increased exposure to coastal winds and it is subject to a comprehensive maintenance program. Previous inspections indicated an extensive refit including painting on all 32 towers. Due to the environmentally sensitive and geographic conditions in this region, and to ensure reliability of supply to customers, the required renewal works will be complex and need to be completed in stages outside of summer peak load and wet seasons. As a result it has been identified that an extended delivery timeframe of at least six years will be required with consultation anticipated to commence within the next 12 months.

### **Project driver:**

Emerging conditions risks due to structural corrosion.

### **Project timing: staged to December 2026**

Taking into account the most recent information received, subsequent analysis and understanding of the risks arising from:

- the condition and network connectivity of both of the 275kV transmission lines
- ongoing network supply needs in the Far North and Ross zones
- the complexity of undertaking works in environmentally sensitive areas and
- the associated delivery of any potential network solutions in the required timeframe including consideration of the impact of outages

There is an opportunity for Powerlink to consider an integrated approach to optimise any potential reinvestment required, delivering positive outcomes for customers. Given the size of the proposed investment and the associated technical requirements, undertaking an integrated, staged approach may also increase the potential to utilise non-network solutions.

### Possible network solutions

Maintaining the existing 275kV network topography and capacity through staged line refits or selective rebuild on:

- Chalumbin to Woree 275kV transmission line by 2024, and Ross to Chalumbin 275kV transmission line to achieve 15 to 20 year life extension by December 2026.
- potential network reconfiguration through a combination of staged line refits or replacement of the existing 275kV transmission lines as per options above, and uprating one circuit of the 132kV coastal transmission line to 275kV by December 2026.

*Proposed network solution: Maintaining 275kV network topology through staged line refit projects of the Chalumbin to Woree 275kV transmission line at an estimated cost of \$30 to \$40 million by December 2024, and the Ross to Chalumbin 275kV transmission line at an estimated cost of \$85 to \$165 million by December 2026.*

Powerlink considers the proposed network solution will not have a material inter-network impact.

### Possible non-network solutions

The Ross to Chalumbin transmission lines provide injection to the Far North area of close to 400MW at peak and up to 7,000MWh per day.

The Chalumbin to Woree transmission lines provide injection to the Cairns area of over 275MW at peak and approximately 4,000MWh per day. Voltage stability governs the maximum supportable power transfer that can be injected into the Cairns and FNQ area.

It should be noted that the network configuration facilitates the provision of voltage control and system strength from local synchronous generation. This would need to be taken into consideration for all non-network solutions.

## Substations

### Innisfail 132kV Substation

*Anticipated consultation: Addressing the secondary systems condition risks at Innisfail*

Innisfail Substation is a 132/22kV bulk supply point for Ergon Energy in FNQ. The 132kV assets were built as part of the Kareeya Power Station hydroelectricity project during the late 1950s, which established the 132kV transmission system to provide electricity to expanding coastal communities in the region. Innisfail Substation was rebuilt in 2003 and the secondary systems installed as part of this rebuild are anticipated to reach end of technical service life around 2023.

### Project driver:

Condition driven replacement to address emerging obsolescence and compliance risks on 132kV secondary systems.

### Project timing: December 2024

### Possible network solutions

- Selected replacement of the secondary systems components by December 2024
- Full replacement of all secondary systems and associated panels in a new building by December 2024.

*Proposed network solution: full replacement of all secondary systems and associated panels in a new building at an estimated cost of \$11 million by December 2024.*

Powerlink considers the proposed network solution will not have a material inter-network impact.

### Possible non-network solutions

Potential non-network solutions would need to provide supply to the 22kV network at Innisfail of up to a peak of 30MW, and up to a 560MWh per day on a continuous basis. This would facilitate the removal of Innisfail Substation and connection of the Innisfail to Edmonton transmission line to the Innisfail to El Arish transmission line.



# 5 Future network development

## Edmonton 132/22kV Substation

### *Anticipated consultation: Addressing the secondary systems condition risks at Edmonton*

Edmonton Substation, established in 2005, is an essential 132kV switching station and bulk supply point for Ergon Energy that provides supply to coastal communities between Townsville and Cairns and support to the Cairns area in the event of a contingency on the 275kV lines supplying FNQ. Majority of Edmonton secondary systems are anticipated to reach end of technical service life around 2026.

#### **Project driver:**

Condition driven replacement to address emerging obsolescence and compliance risks on 132kV secondary systems.

#### **Project timing: June 2026**

#### **Possible network solutions**

- Selected replacement of secondary systems components by June 2026
- Full replacement of secondary systems components by June 2026.

*Proposed network solution: Selected replacement of secondary systems at an estimated cost of \$6 million by June 2026*

Powerlink considers the proposed network solution will not have a material inter-network impact.

#### **Possible non-network solutions**

Potential non-network solutions would need to provide supply to the 22kV network at Edmonton of up to 55MW at peak and up to 770MWh per day. The non-network solution would be required for a contingency and to be able to operate on a continuous basis until normal supply is restored. Supply would also be required for planned outages.

#### ***Possible network reinvestments in the Far North zone within five years***

Against the backdrop of a rapidly changing electricity sector, Powerlink's planning overview (10-year outlook period of the TAPR) includes consideration of a broad range of options to address the identified needs in the Far North zone. As assets approach their anticipated end of technical service life, the potential projects and alternatives (options) listed in Table 5.8 will be subject to detailed planning to confirm alignment with future reinvestment, optimisation and delivery strategies. This near-term analysis provides Powerlink with an additional opportunity to assess the needs and timing of asset replacement works and deliver greater benefits to customers. This will be achieved through improving and further refining options or considering other options, including the associated delivery strategies, from those described in Table 5.8. Information in relation to potential projects, alternatives and possible commissioning needs will be revised annually within the TAPR based on the latest information available at the time.

**Table 5.8** Possible network reinvestments in the Far North zone within five years

Potential project	High level scope	Purpose	Possible commissioning date	Alternatives	Indicative cost
<b>Transmission lines</b>					
Line refit works on the 275kV transmission lines between Chalumbin and Woree substations (section between Davies Creek and Bayview Heights)	Staged line refit works on steel lattice structures	Maintain supply reliability to the Far North and Ross zones	Staged works by June 2024 (1)	New transmission line (2)	\$30m to \$40m (3)
Line refit works on the 275kV transmission lines between Ross and Chalumbin substations	Staged line refit works on steel lattice structures	Maintain supply reliability to the Far North and Ross zones	Staged works by December 2026	New transmission line (2)	\$85m to \$165m (4)
<b>Substations</b>					
Retirement of one 132/22kV Cairns transformer	Retirement of one 132kV Cairns transformer including primary plant reconfiguration works (5) (6)	Maintain supply reliability to the Far North zone	December 2022	Replacement of the transformer	\$3m (1) (3)
Tully 132/22kV transformer replacement	Replacement of the transformer	Maintain supply reliability to the Far North zone	June 2024	Life extension of the existing transformer	\$5m
Innisfail 132kV secondary systems replacement	Full replacement of 132kV secondary systems	Maintain supply reliability to the Far North zone	December 2024 (1)	Replacement of selected secondary systems equipment (2)	\$11m (3)
Chalumbin 275/132kV secondary systems replacement	Selective replacement of 132kV secondary systems	Maintain supply reliability to the Far North zone	December 2025	Full replacement of 132kV secondary systems	\$5m
Edmonton 132kV secondary systems replacement	Full replacement of 132kV secondary systems	Maintain supply reliability to the Far North zone	June 2026	Selected replacement of 132kV secondary systems (2)	\$6m

# 5 Future network development

Notes:

- (1) The revised timing from the 2019 TAPR is based upon the latest condition assessment.
- (2) The envelope for non-network solutions is defined in Section 5.7.1.
- (3) Compared to the 2019 TAPR, the increase in the estimated cost of the proposed network solution is based upon updated information in relation to the construction costs of recently completed projects.
- (4) The project cost will be dependent upon assessment of technical feasibility and commercial analysis of first intervention options to maintain network topography before second intervention is required.
- (5) Due to the extent of available headroom, the retirement of this transformer does not bring about a need for non-network solutions to avoid or defer load at risk or future network limitations, based on AEMO's Central scenario forecast discussed in Chapter 2.
- (6) Operational works, such as asset retirements, do not form part of Powerlink's capital expenditure budget.

### ***Possible network reinvestments within six to 10 years***

As a result of the annual planning review, Powerlink has identified that the following reinvestments are likely to be required to address the risks arising from network assets reaching end of technical service life and to maintain reliability of supply in the Far North zone from around 2026/27 to 2030/31 (refer to Table 5.9).

**Table 5.9** Possible network reinvestments in the Far North zone within six to 10 years

Potential project	High level scope	Purpose	Possible commissioning date	Alternatives	Indicative costs
<b>Transmission Lines</b>					
Rebuild the 132kV transmission line between Woree and Kamerunga substations	New 132kV double circuit transmission line	Maintain supply reliability to the Far North zone	December 2026 (1)	Two 132kV single circuit transmission lines (2)	\$40m (3)
275/132kV substation establishment to maintain supply to Turkinje substation	Establishment of 275/132kV switching substation near Turkinje including two transformers	Maintain supply reliability to Turkinje area	June 2029	Refit of the Chalumbin to Turkinje 132kV transmission line	\$37m
<b>Substations</b>					
Barron Gorge 132kV secondary systems replacement	Full replacement of 132kV secondary systems	Maintain supply reliability to the Far North zone	December 2026	Selected replacement of 132kV secondary systems	\$3m
Turkinje 132kV primary plant replacement	Selected replacement of 132kV primary plant	Maintain supply reliability to the Far North zone	December 2026	Full replacement of 132kV primary plant	\$3m (3)
Kamerunga 132/22kV Transformer Replacement	Replacement of the transformer	Maintain supply reliability to Cairns northern beaches area	December 2028	Significant load transfers in distribution network  Early replacement with higher capacity transformer by 2023 triggered by load growth	\$5m
Chalumbin 275kV and 132kV primary plant replacement	Selected replacement of 275kV and 132kV primary plant	Maintain supply reliability to the Far North zone	December 2028 (1)	Full replacement of all 275kV and 132kV primary plant and secondary systems	\$7m (3)
Woree 275kV and 132kV secondary systems replacement	Selected replacement of 275kV and 132kV secondary systems	Maintain supply reliability to the Far North zone	June 2029 (1)	Full replacement of 275kV and 132kV secondary systems	\$16m
El Arish 132kV secondary systems replacement	Selected replacement of 132kV secondary systems	Maintain supply reliability to the Far North zone	June 2031	Full replacement of 275kV and 132kV secondary systems	\$5m

Notes:

- (1) The change in timing of the network solution is based upon updated information on the condition of the assets.
- (2) The envelope for non-network solutions is defined in Section 5.7.1.
- (3) Compared to the 2019 TAPR, the increase in the estimated cost of the proposed network solution is based upon updated information in relation to the construction costs of recently completed projects.

# 5 Future network development

## Possible asset retirements in the 10-year outlook period<sup>15</sup>

Retirement of one of the 132/22kV transformers at Cairns Substation.

Planning analysis has shown that, based on AEMO's Central scenario forecast discussed in Chapter 2, there is no enduring need for one of the three transformers at Cairns Substation, which is approaching end of technical service life within the next five years. Retirement of the transformer provides cost savings through the avoidance of capital expenditure to address the condition and compliance risks arising from the asset remaining in-service. Some primary plant reconfiguration may be required to realise the benefits of these cost savings at an indicative cost of \$3 million. There may also be additional works and associated costs on Ergon Energy's network which requires joint planning closer to the proposed retirement in December 2022 (refer to Table 5.8).

Retirement of the 132kV transmission line between Chalumbin and Turkinje substations.

Condition assessment has identified emerging condition risks arising from the condition of 132kV transmission line between Chalumbin and Turkinje around 2029. At this time, an option would be to establish a 275/132kV switching station near Turkinje to provide 132kV connection and retirement of the existing 132kV transmission line.

## 5.7.2 Ross zone

### Existing network

The 132kV network between Collinsville and Townsville was developed in the 1960s and 1970s to supply mining, commercial and residential loads. The 275kV network within the zone was developed more than a decade later to reinforce supply into Townsville and FNQ. Parts of the 132kV network are located closer to the coast in a high salt laden wind environment leading to accelerated structural corrosion (refer to figures 5.4 and 5.5).

Figure 5.4 Northern Ross zone transmission network

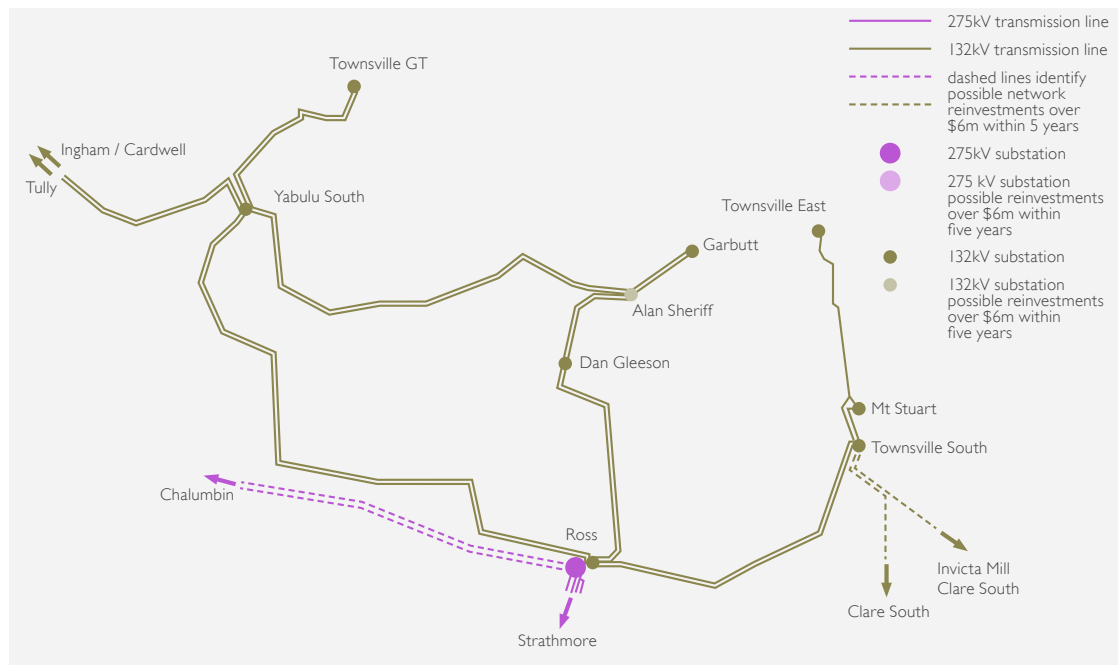

<sup>15</sup> Operational works, such as asset retirements, do not form part of Powerlink's capital expenditure budget.

**Figure 5.5** Southern Ross zone transmission network



**Possible load driven limitations**

Based on AEMO’s Central scenario forecast discussed in Chapter 2, there is no additional capacity forecast to be required as a result of network limitations in the Ross zone within the next five years to meet reliability obligations.

**Possible network reinvestments within five years**

Network reinvestments in Ross zone are related to addressing the risks arising from the condition of the existing network assets, which without corrective action, would result in Powerlink being exposed to breaching a number of its jurisdictional network, safety, environmental and Rules’ obligations.

By addressing the condition of these existing assets, Powerlink is seeking to ensure it can safely deliver an adequate, economic, and reliable supply of electricity to meet the load requirements of customers in the Ross zone into the future. This may result in like-for-like replacement, non-network solutions, network reconfiguration, asset retirement, line refit or replacement with an asset of lower capacity.

**Substations**

**Ingham South 132kV Substation**

*Potential consultation: Addressing the secondary systems condition risks at Ingham South*

Ingham South Substation was established in 2005 and is a major injection point into Ergon Energy’s 66kV distribution network providing supply to the Ingham area. The secondary systems installed are anticipated to reach end of technical service life around 2025.

**Project driver:**

Condition driven replacement to address emerging obsolescence and compliance risks on 132kV secondary systems.

**Project timing: June 2025**

**Possible network solutions**

- Selected replacement of the secondary systems components by June 2025.
- Full replacement of all secondary systems and associated panels in a new building by June 2025.

# 5 Future network development

*Proposed network solution: Full replacement of secondary systems at an estimated cost of \$6 million by June 2025*

Powerlink considers the proposed network solution will not have a material inter-network impact.

## **Possible non-network solutions**

Potential non-network solutions would need to provide supply to the 66kV network at Ingham South of up to 20MW and up to 280MWh per day. The non-network solution would be required for a contingency and to be able to operate on a continuous basis until normal supply is restored. Supply would also be required for planned outages.

## **Alan Sherriff 132kV Substation**

*Potential consultation: Addressing the secondary systems condition risks at Alan Sherriff*

Alan Sherriff Substation was established in 2002 as a two transformer substation, and replaced the 132kV switching functions at Garbutt in 2004. The substation is a major injection point into Ergon Energy's 66kV distribution network providing supply to the Townsville area.

## **Project driver:**

Addressing the secondary systems condition risks at Alan Sherriff Substation.

## **Project timing: June 2025**

## **Possible network solutions**

- Full replacement of all secondary systems.
- Selected replacement of secondary systems, with decommissioning or extended maintenance of the two bays associated with the Dan Gleeson to Alan Sheriff transmission line.

*Proposed network solution: Selected replacement of secondary systems at estimated cost of \$11 million by June 2025*

Powerlink considers the proposed network solution will not have a material inter-network impact.

## **Possible non-network solutions**

Potential non-network solutions would need to provide supply to the 11kV network in north east Townsville of up to 25MW at peak and up to 450MWh per day. Reconfiguration of the 132kV network at Alan Sherriff, and of the Townsville 66kV network around Townsville, would be required to facilitate removal of Alan Sherriff Substation.

## **Possible network reinvestments in the Ross zone within five years**

Against the backdrop of a rapidly changing electricity sector, Powerlink's planning overview (10-year outlook period of the TAPR) includes consideration of a broad range of options to address the identified needs in the Ross zone. As assets approach their anticipated end of technical service life, the potential projects and alternatives (options) listed in Table 5.10 will be subject to detailed planning to confirm alignment with future reinvestment, optimisation and delivery strategies. This near-term analysis provides Powerlink with an additional opportunity to assess the needs and timing of asset replacement works and deliver greater benefits to customers. This will be achieved through improving and further refining options or considering other options, including the associated delivery strategies, from those described in Table 5.11. Information in relation to potential projects, alternatives and possible commissioning needs will be revised annually within the TAPR based on the latest information available at the time.

**Table 5.10** Possible network reinvestments in the Ross zone within five years

Potential project	High level scope	Purpose	Possible commissioning date	Alternatives	Indicative cost
Substations					
Ingham South 132kV secondary systems replacement	Full replacement of 132kV secondary systems	Maintain supply reliability to the Ross zone	June 2025	Selected replacement of 132kV secondary systems (1)	\$6m
Garbutt 132kV secondary systems replacement	Full replacement of 132kV secondary systems	Maintain supply reliability to the Ross zone	June 2025	Selected replacement of 132kV secondary systems	\$5m
Alan Sherriff 132kV secondary systems replacement	Selected replacement of 132kV secondary systems	Maintain supply reliability to the Ross zone	June 2025	Full replacement of 132kV secondary systems (1)	\$11m

Note:

(1) The envelope for non-network solutions is defined in this Section 5.7.2.

***Possible network reinvestments within six to 10 years***

As a result of the annual planning review, Powerlink has identified that the following reinvestments are likely to be required to address the risks arising from network assets reaching end of technical service life and to maintain reliability of supply in the Ross zone from around 2026/27 to 2030/31 (refer to Table 5.11).



# 5 Future network development

**Table 5.11** Possible network reinvestments in the Ross zone within six to 10 years

Potential project	High level scope	Purpose	Possible commissioning date	Alternatives	Indicative cost
<b>Transmission lines</b>					
Line refit works on the 132kV transmission line between Townsville South and Ross substations	Targeted line refit works on steel lattice structures	Maintain supply reliability in the Ross zone	June 2028	New 132kV transmission line  Targeted line refit works on steel lattice structures with painting	\$2m
Line refit works on the 132kV transmission line between Ross and Dan Gleeson substations	Line refit works on steel lattice structures	Maintain supply reliability to the Ross zone	June 2028	New 132kV transmission line	\$8m
Line refit works on the 132kV transmission lines between Collinsville, Strathmore and Clare South substations	Line refit works on steel lattice structures	Maintain supply reliability to the Ross zone	June 2030 (1)	New 132kV transmission line	\$20m
Line refit works on the northern end of the 275kV transmission lines between Strathmore and Ross substations	Targeted line refit works on the 275kV steel lattice towers	Maintain supply reliability between Strathmore and Ross	June 2030 (1)	New transmission line	\$6m
<b>Substations</b>					
Townsville East 132kV secondary systems replacement	Staged replacement of secondary systems	Maintain supply reliability to the Ross zone	June 2028	Full replacement of secondary systems	\$3m
Townsville South 132kV secondary systems replacement	Selected replacement of 132kV secondary systems	Maintain supply reliability to the Ross zone	June 2028	Full replacement of 132kV secondary systems	\$15m
Yabalu South 132kV secondary systems replacement	Selected replacement of 132kV secondary systems	Maintain supply reliability to the Ross zone	June 2029	Full replacement of 132kV secondary systems	\$7m
Clare South 132kV secondary systems replacement	Selected replacement of 132kV secondary systems	Maintain supply reliability to the Ross zone	June 2029	Full replacement of 132kV secondary systems	\$11m
Ross 275/132kV secondary systems replacement	Selective replacement of secondary systems	Maintain supply reliability to the Ross zone	June 2030	Full replacement of secondary systems	\$8m

**Table 5.11** Possible network reinvestments in the Ross zone within six to 10 years (*continued*)

Potential project	High level scope	Purpose	Possible commissioning date	Alternatives	Indicative cost
Bowen North 132kV secondary systems replacement	Selective replacement of secondary systems	Maintain supply reliability to the Ross zone	June 2031	Full replacement of secondary systems	\$3m

Note:

(1) The revised timing from the 2019 TAPR is based upon the latest condition assessment.

**Possible asset retirements in the 10-year outlook period**

**Dan Gleeson to Alan Sherriff 132kV transmission line**

The 132kV transmission line between Dan Gleeson and Alan Sherriff substations was constructed in the 1960s and is located in the south-western suburbs of Townsville. Foundation repair on this transmission line was completed in 2016 to allow the continued safe operation in the medium term. Planning studies are currently underway to assess the viability of potentially retiring this transmission line.

**5.7.3 North zone**

**Existing network**

Three 275kV circuits between Nebo (in the south) and Strathmore (in the north) substations form part of the 275kV transmission network supplying the North zone. Double circuit inland and coastal 132kV transmission lines supply regional centres and infrastructure related to mines, coal haulage and ports arising from the Bowen Basin mines (refer to Figure 5.6).

The coastal network in this zone is characterised by transmission line infrastructure in a corrosive environment which make it susceptible to premature ageing.

**Figure 5.6** North zone transmission network

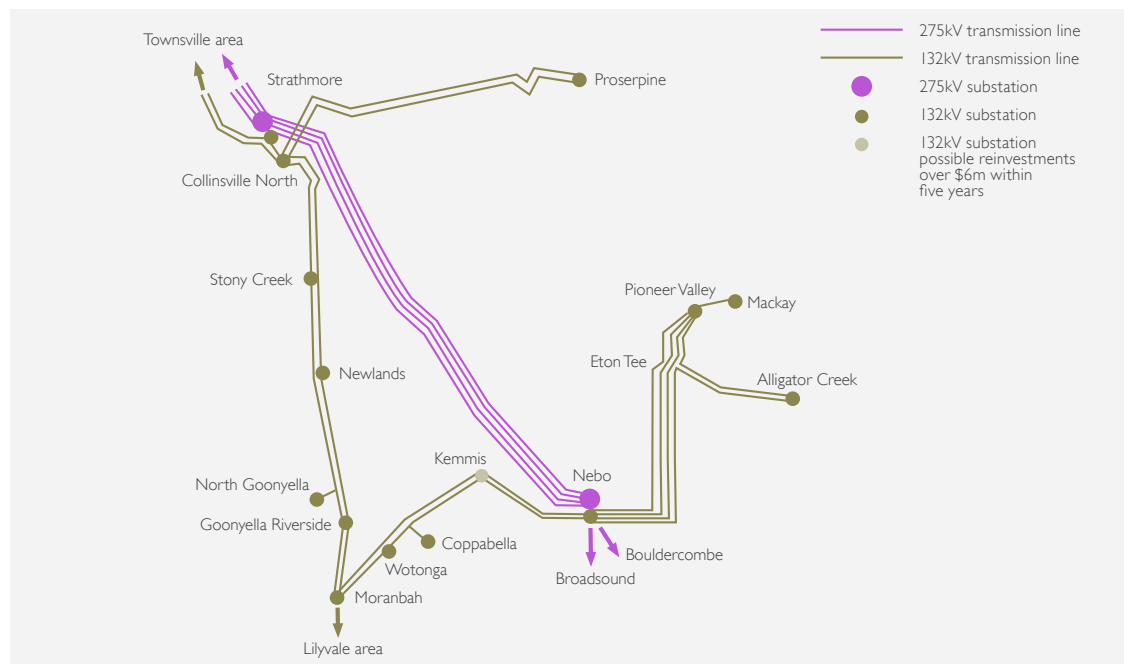

# 5 Future network development

## **Possible load driven limitations**

Based on AEMO's Central scenario forecast discussed in Chapter 2, there is no additional capacity forecast to be required as a result of network limitations in the North zone within the next five years to meet reliability obligations.

Increasing local demand in the Proserpine area is expected to lead to some load at risk. The critical contingency is an outage of the 275/132kV Strathmore transformer.

Based on AEMO's Central scenario forecast discussed in Chapter 2, this places load at risk of 10MW from summer 2020/21, which is within the 50MW and 600MWh limits established under Powerlink's planning standard (refer to Section 1.8).

High voltages associated with light load conditions are currently managed with existing reactive sources. However, midday power transfer levels are forecast to reduce as additional VRE generators are commissioned in NQ. As a result, voltage control is forecast to become increasingly challenging for longer durations. This is discussed in sections 5.7.4 and 6.6.2.

## **Strathmore 275/132kV Substation**

### *Potential consultation: Addressing the Static VAR Compensator (SVC) secondary systems condition risks at Strathmore*

Strathmore Substation was established in 2001. The substation is a major injection point into Ergon Energy's 66kV. It consists of a 275kV and 132kV switchyards.

#### **Project driver:**

Addressing the SVC secondary systems condition risks at Strathmore Substation.

#### **Project timing: June 2026**

#### **Possible network solutions**

- Selected replacement of the secondary systems associated with the SVC.
- Full replacement of all secondary systems associated with the SVC.
- Full replacement of secondary systems associated with the SVC and selected secondary systems for the 275kV/132kV switchyard.

*Proposed network solution: Full replacement of secondary systems associated with the SVC at Strathmore at estimated cost of \$6 million by June 2026*

Powerlink considers the proposed network solution will not have a material inter-network impact.

#### **Possible non-network solutions**

Potential non-network solutions would need to provide dynamic voltage support of up to 150MVARs capacitive and 80MVARs inductive.

## **Possible network reinvestments in the North zone within five years**

Against the backdrop of a rapidly changing electricity sector, Powerlink's planning overview (10-year outlook period of the TAPR) includes consideration of a broad range of options to address the identified needs in the North zone. As assets approach their anticipated end of technical service life, the potential projects and alternatives (options) listed in Table 5.12 will be subject to detailed planning to confirm alignment with future reinvestment, optimisation and delivery strategies. This near-term analysis provides Powerlink with an additional opportunity to assess the needs and timing of asset replacement works and deliver greater benefits to customers. This will be achieved through improving and further refining options or considering other options, including the associated delivery strategies, from those described in Table 5.12. Information in relation to potential projects, alternatives and possible commissioning needs will be revised annually within the TAPR based on the latest information available at the time.

Network reinvestments in the North zone are related to addressing the risks arising from the condition of the existing network assets, which without corrective action, would result in Powerlink being exposed to breaching a number of its jurisdictional network, safety, environmental and Rules' obligations.

By addressing the condition of these existing assets, Powerlink is seeking to ensure it can safely deliver an adequate, economic, and reliable supply of electricity to meet the load requirements of customers in the North zone into the future. This may result in like for like replacement, non-network solutions, network reconfiguration, asset retirement, line refit or replacement with an asset of lower capacity.

**Table 5.12** Possible network reinvestments in the North zone within five years

Potential project	High level scope	Purpose	Possible commissioning date	Alternatives	Indicative cost
Substations					
Nebo 132/11kV transformer replacements	Replacement of two 132/11kV transformers	Maintain supply reliability to the North zone	June 2022	Establish 11kV supply from surrounding network	\$5m (2)
Alligator Creek 132kV primary plant replacement	Selective replacement of 132kV primary plant	Maintain supply reliability in the North zone	June 2022 (1)	Full replacement of 132kV primary plant	\$4m
North Goonyella 132kV secondary systems replacement	Full replacement of 132kV secondary systems	Maintain supply reliability to the North zone	December 2023 (1)	Selective replacement of 132kV secondary systems	\$2m
Newlands 132kV primary plant replacement	Staged replacement of 132kV primary plant	Maintain supply reliability in the North zone	December 2023 (1)	Replacement of all 132kV primary plant	\$5m (3)
Strathmore SVC secondary systems replacement	Full replacement of secondary systems	Maintain supply reliability to the Ross zone	June 2026	Staged replacement of secondary systems (1)	\$6m
Strathmore 275kV and 132kV partial secondary systems replacement - Stage 2	Selective replacement of 275 and 132kV secondary systems in a new prefabricated building	Maintain supply reliability to the North zone	December 2028	Selected replacement of 275 and 132kV secondary systems in existing panels	\$14m

Notes:

- (1) The envelope for non-network solutions is defined in this Section 5.7.3
- (2) The revised timing from the 2019 TAPR is based upon the latest condition assessment.
- (3) Compared to the 2019 TAPR, the increase in the estimated cost of the proposed network solution is based upon updated information in relation to required scope of works.
- (4) Compared to the 2019 TAPR, the increase in the estimated cost of the proposed network solution is based upon updated information in relation to the construction costs of recently completed projects.

#### **Possible network reinvestments within six to 10 years**

As a result of the annual planning review, Powerlink has identified that the following reinvestments are likely to be required to address the risks arising from network assets reaching end of technical service life and to maintain reliability of supply in the North zone from around 2026/27 to 2030/31 (refer to Table 5.13).

# 5 Future network development

**Table 5.13** Possible network reinvestments in the North zone within six to 10 years

Potential project	High level scope	Purpose	Possible commissioning date	Alternatives	Indicative cost
Transmission lines					
Line refit works on the 132kV transmission line between Nebo Substation and Eton tee	Line refit works on steel lattice structures	Maintain supply reliability to the North zone	December 2027 (1)	New transmission line	\$31m
Substations					
Kemmis 132/66kV transformer replacement	Replacement of one 132/66kV transformers	Maintain supply reliability to the North zone	June 2028	Establish 66kV supply from surrounding network	\$4m
Alligator Creek SVC and 132kV secondary systems replacement	Full replacement of 132kV secondary systems	Maintain supply reliability to the North zone	June 2028	Staged replacement of 132kV secondary systems	\$15m
Pioneer Valley 132kV primary plant replacement	Selective replacement of 132kV secondary systems equipment	Maintain supply reliability to the North zone	December 2028	Full replacement of 132kV secondary systems	\$6m
Mackay 132/33kV transformer replacement	Replacement of one 132/33kV transformer	Maintain supply reliability to the North zone	June 2030	Establish 33kV supply from surrounding network	\$5m

Note:

(1) The revised timing from the 2019 TAPR is based upon the latest condition assessment.

### **Possible asset retirements within the 10-year outlook period**

#### **Pioneer Valley to Eton tee 132kV transmission line**

Subject to the outcome of further analysis, Powerlink may retire the inland transmission line at the end of its service life anticipated around 2027.

## **5.7.4 Central West zone**

### **Existing network**

The Central West 132kV network was developed between the mid-1960s and late 1970s to meet the evolving requirements of mining activity in the southern Bowen Basin. The 132kV injection points for the network are taken from Calvale and Lilyvale 275kV substations. The network is located more than 150km from the coast in a dry environment making infrastructure less susceptible to corrosion. As a result transmission lines and substations in this region have met (and in many instances exceeded) their anticipated service life but will require replacement or rebuilding in the near future (refer to Figure 5.7).

Figure 5.7 Central West 132kV transmission network

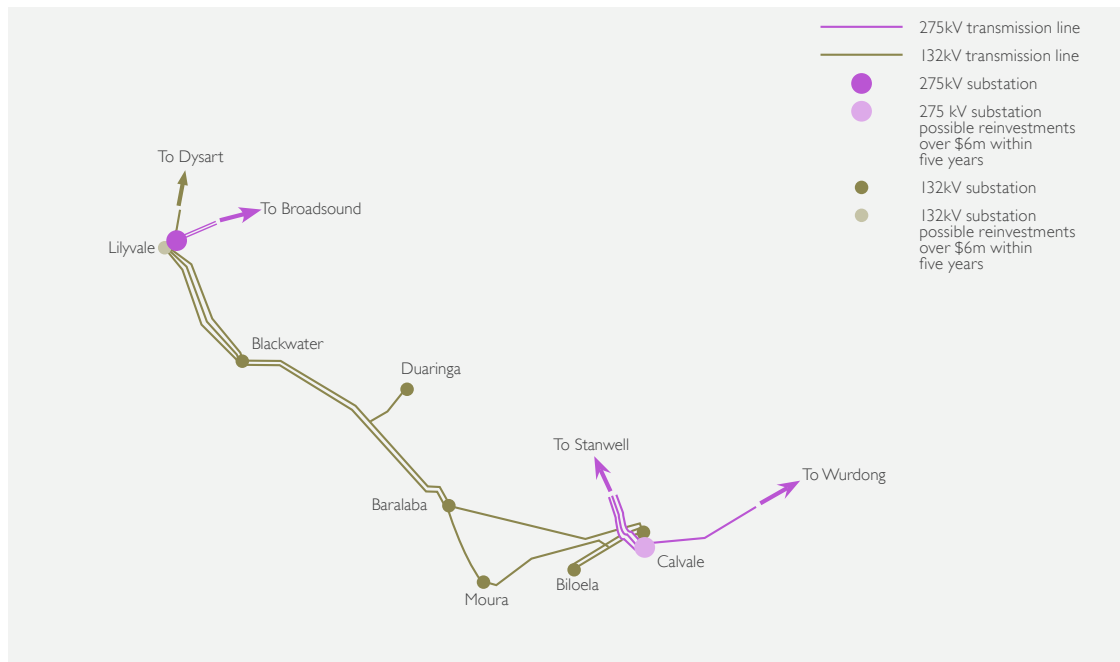

#### Possible load driven limitations

Based on AEMO's Central scenario forecast discussed in Chapter 2 and the committed generation described in tables 6.1 and 6.2, there is no additional capacity forecast to be required in the Central West zone within the next five years to meet reliability obligations.

#### Possible network investments to address non-load driven network constraints in the next five years

High voltages associated with light load conditions are currently managed with existing reactive sources. However, midday power transfer levels are forecast to reduce as additional VRE generators are commissioned in NQ, leading to greater utilisation of voltage control plant in the Central Queensland (CQ) and NQ zones. As a result, voltage control is forecast to become increasingly challenging for longer durations and potentially lead to high voltage (HV) violations (that is, voltages exceed defined safe operating limits).

Powerlink has in the past used operational line switching to reduce voltages to within safe operating limits. Line switching can lead to reduced reliability arising from non-credible events, and can lead to reduced system strength.

The lines required to be switched to mitigate higher operational voltages in NQ and CQ, are the lines that have the largest impact on the system strength in NQ. The reduction in system strength from line switching may breach Powerlink's obligations under clauses 11.101.2 and 4.6.6 of the NER, as amended by the National Electricity Amendment (Managing power system fault levels) Rule 2017 No. 10 (Fault Levels Rule) and this may result in VRE generators in NQ being constrained to ensure system strength is maintained.

#### Anticipated consultation: Managing CQ voltages

##### Project driver:

Voltage control during light load conditions.

Powerlink has identified a need for additional reactive support, to:

- Maintain voltages within operational and design limits during minimum demand periods and to maintain the power system in a secure operating state;
- Reduce reliability impact from the de-energisation of 275kV transmission lines; and
- Reduce market constraints to meet system strength requirements.

# 5 Future network development

**Project timing: December 2021**

## **Possible network solutions**

- Installation of a 150MVAR 300kV bus reactor at Broadsound
- Installation of a 150MVAR 300kV bus reactor at Nebo

*Proposed network solution: Installation of a 150MVAR 300kV bus reactor at Broadsound at an estimated cost of \$9 million by June 2023*

The network risk associated with this limitation is currently being managed through a range of short-term operational measures including rescheduling of outages and the selective switching out of lines as required, until such time as the most economic long-term solution can be implemented. Subject to the outcome of a RIT-T consultation, the earliest likely timing of delivery of works for a network solution, which has been impacted by the restrictions of the COVID-19 pandemic, is June 2023.

Powerlink considers the proposed network solution will not have a material inter-network impact.

## **Possible non-network solutions**

Under system normal conditions, network support would need to provide voltage control equivalent to the proposed reactor at or near Nebo or Broadsound, being 126MVAR at the 275kV bus. Reactive support would be required to be available on a continuous basis, and not be coupled to generation output. The nature of this limitation is that the voltage control would be required to operate on a continuous basis.

## **Possible network reinvestments within five years**

Network reinvestments in Central West zone are related to addressing the risks arising from the condition of the existing network assets, which without corrective action, would result in Powerlink being exposed to breaching a number of its jurisdictional network, safety, environmental and Rules' obligations.

By addressing the condition of these existing assets, Powerlink is seeking to ensure it can safely deliver an adequate, economic, and reliable supply of electricity to meet the load requirements of customers in the Central West zone into the future. This may result in like-for-like replacement, non-network solutions, network reconfiguration, asset retirement, line refit or replacement with an asset of lower capacity.

## **Substations**

Powerlink has identified opportunities to reconfigure the network in the Central West zone providing efficiencies and cost savings by:

- reducing the number of transformers at Bouldercombe Substation, where as an outcome of a RIT-T, two of the existing transformers will be retired and replaced by a single transformer by December 2021; and
- re-arrangement of the 132kV network around Callide A Substation by the establishment of a second transformer at Calvale Substation and retirement of Callide A Substation and the Callide A to Gladstone South transmission line. A committed project is currently underway to establish a second transformer at Calvale Substation (refer to Table 9.3).

**Possible network investments in the Central West zone within five years**

Against the backdrop of a rapidly changing electricity sector, Powerlink’s planning overview (10-year outlook period of the TAPR) includes consideration of a broad range of options to address the identified needs in the Central West zone. As assets approach their anticipated end of technical service life, the potential projects and alternatives (options) listed in Table 5.14 will be subject to detailed planning to confirm alignment with future reinvestment, optimisation and delivery strategies. This near-term analysis provides Powerlink with an additional opportunity to assess the needs and timing of asset replacement works and deliver greater benefits to customers. This will be achieved through improving and further refining options or considering other options, including the associated delivery strategies, from those described in Table 5.14. Information in relation to potential projects, alternatives and possible commissioning needs will be revised annually within the TAPR based on the latest information available at the time.

**Table 5.14** Possible network investments in the Central West zone within five years

Potential project	High level scope	Purpose	Possible commissioning date	Alternatives	Indicative cost
Substations					
150MVAr 300kV bus reactor at Broadsound	Installation of a 150MVAr 300kV bus reactor at Broadsound Substation	Voltage control in CQ	June 2023	Installation of a 150MVAr 300kV bus reactor at Nebo (1)	\$9m
Blackwater 132kV primary plant replacement	Selective replacement of 132kV primary plant	Maintain supply reliability in the Central West zone	June 2025	Full replacement of 132kV primary plant	\$3m
Biloela 132kV secondary systems replacement	Selective replacement of 132kV secondary systems	Maintain supply reliability in the Central West zone	June 2025	Full replacement of 132kV secondary systems	\$4m
Lilyvale 132kV secondary systems replacement	Selective replacement of 132kV secondary systems	Maintain supply in the Central West zone	June 2025	Full replacement of 132kV secondary systems	\$3m

Note:

(1) The envelope for non-network solutions is defined in Section 5.7.4.

**Possible network reinvestments within six to 10 years**

As a result of the annual planning review, Powerlink has identified that the following reinvestments are likely to be required to address the risks arising from network assets reaching end of technical service life and to maintain reliability of supply in the Central West zone from around 2026/27 to 2030/31 (refer to Table 5.15).



## 5 Future network development

**Table 5.15** Possible network reinvestments in the Central West zones within six to 10 years

Potential project	High level scope	Purpose	Possible commissioning date	Alternatives	Indicative cost
Transmission lines					
Line refit works on the 275kV transmission line between Bouldercombe and Nebo substations	Line refit works on the 275kV transmission line	Maintain supply reliability in the Central West zone	December 2027	Stanwell to Broadsound 2 <sup>nd</sup> side stringing  New 275kV transmission line between Bouldercombe and Broadsound substation	\$24m
Line refit works on the 132kV transmission line between Callide A, Biloela and Moura	Line refit works on the 132kV transmission line and repair selected foundations	Maintain supply reliability in the Central West zone	June 2028	Rebuild the 132kV transmission lines as a double circuit from Callide A to Moura	\$5m
Substations					
Broadsound 275kV primary plant replacement	Selective replacement of 275kV primary plant	Maintain supply reliability in the Central West zone	December 2026	Full replacement of 275kV primary plant	\$15m
Calvale 275kV primary plant replacement	Selective replacement of 275kV primary plant	Maintain supply reliability in the Central West zone	December 2026	Full replacement of 275kV primary plant	\$17m
Broadsound 275kV secondary systems replacement	Selective replacement of 275kV secondary systems	Maintain supply reliability in the Central West zone	June 2027	Full replacement of 275kV secondary systems	\$4m
Blackwater 132kV secondary systems replacement	Selective replacement of 132kV secondary systems	Maintain supply reliability in the Central West zone	June 2029	Full replacement of 132kV secondary systems	\$13m

### *Possible asset retirements within the 10-year outlook period<sup>16</sup>*

Subject to the outcome of further analysis and RIT-T consultation, Powerlink may retire the single circuit transmission lines between Callide and Baralaba, and Baralaba and Moura at the end of its technical service life anticipated around 2028, if a new 132kV double circuit transmission line is constructed between Calvale and Moura substations.

<sup>16</sup> Operational works, such as asset retirements, do not form part of Powerlink's capital expenditure budget.

## 5.7.5 Gladstone zone

### Existing network

The Gladstone 275kV network was initially developed in the 1970s with the Gladstone Power Station and has evolved over time with the addition of the Wurdong Substation and supply into Boyne Smelters Limited (BSL) in the early 1990s (refer to Figure 5.8).

**Figure 5.8** Gladstone transmission network



### Possible load driven limitations

Based on AEMO's Central scenario forecast discussed in Chapter 2, there is no additional capacity forecast to be required in the Gladstone zone within the next five years to meet reliability obligations.

### Possible network reinvestments within five years

Network reinvestments in Gladstone zone are related to addressing the risks arising from the condition of the existing network assets, which without corrective action, would result in Powerlink being exposed to breaching a number of its jurisdictional network, safety, environmental and Rules' obligations - resulting in poor customer, safety and environmental outcomes.

By addressing the condition of these existing assets, Powerlink is seeking to ensure it can deliver a safe, cost effective and reliable supply of electricity to meet the load requirements of customers in the Gladstone zone into the future. This may result in like-for-like replacement, non-network solutions, network reconfiguration, asset retirement, line refit or replacement with an asset of lower capacity.

### Transmission lines

#### Larcom Creek to Calliope 275kV transmission lines

##### *Potential consultation: Maintaining reliability of supply in the Gladstone region*

The transmission line between Calliope River and Larcom Creek was constructed in 1977 and is located in CQ immediately adjacent to the Gladstone industrial area. This built section covers the distance between Calliope River and Larcom Creek via Yarwun substations. A proportion of the transmission line traverses tidal marine environment and due to its proximity to the large-scale industrial areas and the coast it is constantly exposed to high levels of salt laden air and industrial pollutants.

#### Project driver:

Emerging conditions risks due to structural corrosion.

# 5 Future network development

**Project timing: June 2025**

## **Possible network solutions**

- Line refit works on steel lattice structures
- Rebuild the 275kV transmission line between Calliope River and Larcom Creek as SCST construction
- Rebuild the 275kV transmission line between Calliope River and Larcom Creek as DCST construction

*Proposed network solution: Line refit works between Larcom Creek and Calliope River at an estimated cost of \$10 million, by June 2024.*

Powerlink considers the proposed network solution will not have a material inter-network impact.

## **Possible non-network solutions**

Potential non-network solutions would need to provide supply to 66kV and 132kV loads at Yarwun and Raglan of up to 160MW and up to 3200MWh per day. The non-network solution would be required for a contingency and to be able to operate on a continuous basis until normal supply is restored. Supply would also be required for planned outages.

## **Wurdong to Boyne Island 275kV transmission line**

### **Potential consultation: Maintaining reliability of supply in the Gladstone region**

The transmission line provides supply to the Boyne Smelter from the Wurdong substation and was constructed in 1991. Due to its proximity to Boyne Smelter, Gladstone industrial precinct and the coast, it is constantly exposed to high levels of salt laden air and industrial pollutants. As a result, particularly in the more exposed locations, a high percentage of galvanised tower bolts and members are exhibiting evidence extensive corrosion and the line receives additional maintenance to keep it in a serviceable condition.

### **Project driver:**

Emerging condition risks due to structural corrosion.

**Project timing: December 2024**

## **Possible network solutions**

- Line refit works on steel lattice structures
- Rebuild the 275kV transmission line between Wurdong and Boyne as SCST construction
- Rebuild the 275kV transmission line between Wurdong and Boyne as DCST construction

*Proposed network solution: Refit the single circuit transmission line between Wurdong and Boyne substations, at an estimated cost of \$7 million, by December 2024*

Powerlink considers the proposed network solution will not have a material inter-network impact.

## **Possible non-network solutions**

Potential non-network solutions would need to provide supply to the 275kV network at Boyne Island of approximately 400MW and approximately 10,000MWh per day. The non-network solution would be required for a contingency and to be able to operate on a continuous basis until normal supply is restored. Supply would also be required for planned outages.

## **Callemondah to Gladstone South 132kV transmission lines**

### **Potential consultation: Maintaining reliability of supply to Gladstone South**

The Callemondah to Gladstone South 132kV double circuit transmission line was constructed in 1977. The transmission line facilitates supply to Gladstone South Substation which is an Ergon Energy bulk supply point and the connection point for Queensland Alumina Limited (QAL).

### **Project driver:**

Emerging conditions risks due to structural corrosion.

**Project timing: December 2023**

#### Possible network solutions

- Rebuild the 132kV transmission line between Callemondah and Gladstone South substations
- Line refit works on steel lattice structures

*Proposed network solution: Rebuild the double circuit transmission line between Callemondah and Gladstone South substations, at an estimated cost of \$17 million, by December 2023*

Powerlink considers the proposed network solution will not have a material inter-network impact.

#### Possible non-network solutions

Potential non-network solutions would need to provide supply to the 132kV network at Gladstone South of up to 160MW at peak and up to 1,820MWh per day. The non-network solution would be required for a contingency and to be able to operate on a continuous basis until normal supply is restored. Supply would also be required for planned outages.

### Substations

#### Callemondah Substation

Callemondah Substation was established in 1985 and provides supply to the Aurizon supply network. The secondary systems are anticipated to reach end of technical service life around 2024.

*Potential consultation: Maintaining reliability of supply at Callemondah*

#### Project driver:

Addressing the 132kV primary plant and secondary systems condition risks.

#### Project timing: June 2024

#### Possible network solutions

- Full primary plant and secondary systems replacement by June 2024.
- Selective primary plant and secondary systems replacement by June 2024.

*Proposed network solution: Selective primary plant and secondary systems replacement at Callemondah Substation at an estimated cost of \$7 million by June 2024*

Powerlink considers the proposed network solution will not have a material inter-network impact.

#### Possible non-network solutions

Potential non-network solutions would need to provide supply to the 132kV network at Gladstone South and/or Aurizon load at Callemondah, totalling up to 180MW and up to 2,500MWh per day. The non-network solution would be required for a contingency and to be able to operate on a continuous basis until normal supply is restored. Supply would also be required for planned outages.

#### **Possible network reinvestments in the Gladstone zone within five years**

Against the backdrop of a rapidly changing electricity sector, Powerlink's planning overview (10-year outlook period of the TAPR) includes consideration of a broad range of options to address the identified needs in the Gladstone zone. As assets approach their anticipated end of technical service life, the potential projects and alternatives (options) listed in Table 5.16 will be subject to detailed planning to confirm alignment with future reinvestment, optimisation and delivery strategies. This near-term analysis provides Powerlink with an additional opportunity to assess the needs and timing of asset replacement works and deliver greater benefits to customers. This will be achieved through improving and further refining options or considering other options, including the associated delivery strategies, from those described in Table 5.16. Information in relation to potential projects, alternatives and possible commissioning needs will be revised annually within the TAPR based on the latest information available at the time.

## 5 Future network development

**Table 5.16** Possible network reinvestments in the Gladstone zone within five years

Potential project	High level scope	Purpose	Possible commissioning date	Alternatives	Indicative cost
Transmission lines					
Line refit works on the 132kV transmission line between Callemondah and Gladstone South substations	Rebuild the 132kV transmission line between Callemondah and Gladstone South Substation (1)	Maintain supply reliability in the Gladstone zone	December 2023	Line refit works on steel lattice structures (2)	\$17m
Line refit between Larcom Creek and Mt Miller substation	Line refit works on steel lattice structures (2)	Maintain supply reliability in the Gladstone zone	June 2024	Rebuild the 275kV transmission line between Mt Miller and Larcom Creek substation (2)	\$10m
Line refit works on the 275kV transmission line between Wurdong and Boyne Island	Line refit works on steel lattice structures	Maintain supply reliability in the Gladstone zone	December 2024	Rebuild the 275kV transmission line between Wurdong and Boyne Island (2)	\$7m
Substations					
Callemondah selective 132kV primary plant and secondary systems replacement	Selective replacement of 132kV primary plant and secondary systems	Maintain supply reliability in the Gladstone zone	June 2024	Full replacement of 132kV primary plant and secondary systems (2)	\$7m

Notes:

- (1) The envelope for non-network solutions is defined in Section 5.7.5.
- (2) More detailed option analysis and consideration of the associated scope of works to address emerging condition risks on this transmission line has been undertaken since the publication of the 2019 TAPR. This new analysis has supported the development of new strategies and options providing an opportunity to deliver a more cost effective solution than previously identified, delivering positive outcomes for customers.

### **Possible network reinvestments within six to 10 years**

As a result of the annual planning review, Powerlink has identified that the following reinvestments are likely to be required to address the risks arising from network assets reaching end of technical service life and to maintain reliability of supply in the Gladstone zone from around 2026/27 to 2030/31 (refer to Table 5.17).

**Table 5.17** Possible network reinvestments in the Gladstone zone within six to 10 years

Potential project	High level scope	Purpose	Possible commissioning date	Alternatives	Indicative cost
<b>Transmission lines</b>					
Line refit works on 275kV transmission line between Mt Miller and Bouldercombe substations	Line refit works on steel lattice structures	Maintain supply reliability in the Gladstone zone	December 2027	Advancement of the rebuild the 275kV transmission line between Mt Miller and Bouldercombe as a DCST and dismantle the inland circuit	\$5m
Rebuild the 275kV transmission line between Raglan and Larcom Creek substations	Rebuild the 275kV transmission line between Raglan and Larcom Creek as a double circuit line (I)	Maintain supply reliability in the Gladstone zone	June 2030	Line refit works on steel lattice structures  Rebuild the 275kV transmission line between Raglan and Larcom Creek as a single circuit line	\$33m
Rebuild the 275kV transmission line between Raglan and Bouldercombe substations	Rebuild the 275kV transmission line between Raglan and Bouldercombe (I)	Maintain supply reliability in the Gladstone zone	June 2031	Line refit works on steel lattice structures  Rebuild the 275kV transmission line between Raglan and Larcom Creek as a single circuit line	\$75m
<b>Substations</b>					
Rockhampton 132kV secondary systems replacement	Selective replacement of 132kV secondary systems	Maintain reliability at Rockhampton	December 2026	Full replacement of 132kV secondary systems	\$4m
Larcom Creek secondary systems replacement	Selective replacement of 275kV secondary systems	Maintain supply reliability in the Gladstone zone	June 2029	Full replacement of the 275kV secondary systems	\$8m
Yarwun 132kV secondary systems replacement	Full replacement of the 132kV secondary systems	Maintain supply reliability in the Gladstone zone	June 2029	Selective replacement of 132kV secondary systems	\$10m

Note:

- (I) More detailed option analysis and consideration of the associated scope of works to address emerging condition risks on this transmission line has been undertaken since the publication of the 2019 TAPR. This new analysis has supported the development of new strategies and options providing an opportunity to deliver positive outcomes for customers in the longer term.

# 5 Future network development

## Possible asset retirements within the 10-year outlook period<sup>17</sup>

### Callide A to Gladstone South 132kV transmission double circuit line

The 132kV transmission line was constructed in the mid-1960s to support the loads in the Gladstone area. Due to reconfiguration in the area, this transmission line will be retired from service at the end of technical service life within the 10-year outlook period.

## 5.7.6 Wide Bay zone

### Existing network

The Wide Bay zone supplies loads in the Maryborough and Bundaberg region and also forms part of Powerlink's eastern Central Queensland to South Queensland (CQ-SQ) transmission corridor. This corridor was constructed in the 1970s and 1980s and consists of single circuit 275kV transmission lines between Calliope River and South Pine (refer to Figure 5.8). These transmission lines traverse a variety of environmental conditions and as a result exhibit different corrosion rates and risk profiles.

Figure 5.9 CQ-SQ transmission network

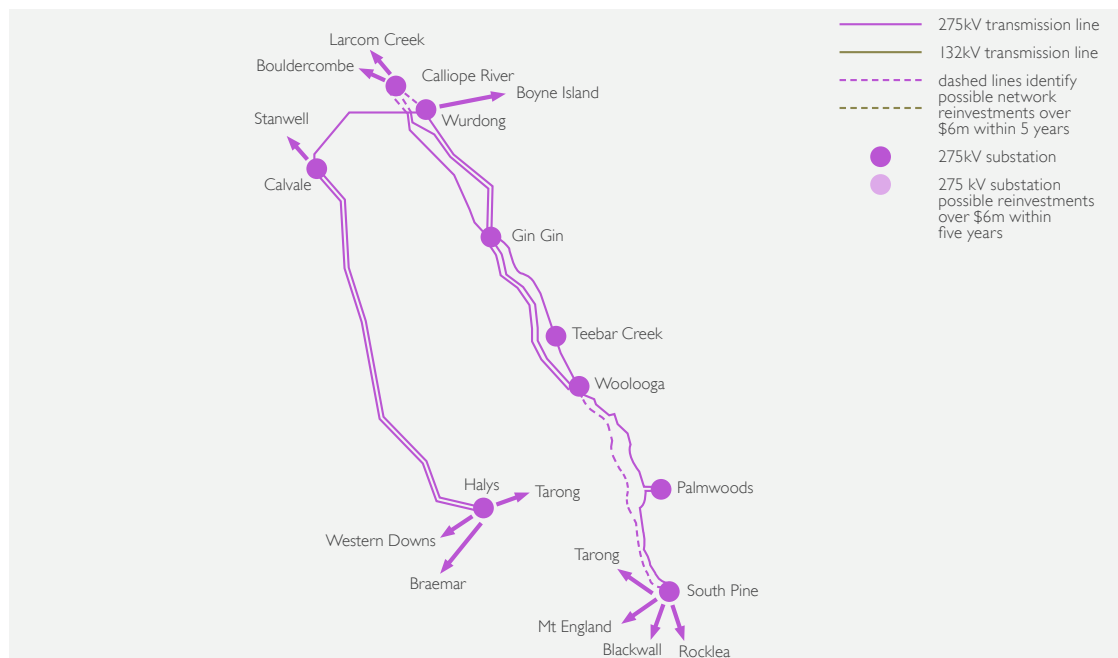

### Possible load driven limitations

Based on AEMO's Central scenario forecast discussed in Chapter 2, there is no additional capacity forecast to be required in the Wide Bay zone within the next five years to meet reliability obligations.

### Transmission network overview

In the NEM, generators compete for dispatch. Briefly, a generator's dispatch level depends on its bid in relation to other generators' bids, demand and available transmission capacity. Congestion occurs when transmission capacity prevents the optimum economic dispatch. Affected generators are said to be 'constrained' by the amount unable to be economically dispatched. Forecast of market constraint durations and levels are sensitive to highly uncertain variables including changes in bidding behaviour, investment patterns, fuel cost dynamics, environmental conditions and demand levels. It is important to note that there is no load at risk or potential for loss of supply to customers associated with network congestion.

<sup>17</sup> Operational works, such as asset retirements, do not form part of Powerlink's capital expenditure budget.

In its current form, the CQ-SQ transmission network offers a great deal of flexibility for possible generation dispatches, however occasionally imposes constraints to market operation. Over time the utilisation of the CQ-SQ grid sections is expected to increase as new NQ and CQ VRE generating systems connect to the transmission network (refer to Section 5.7.5, Section 6.6.4 and Section 7.3.2). In addition, the incidence of congestion may increase as additional southerly transfer capacity on QNI is released following the now committed QNI upgrade project (refer to Section 5.7.14). The incidence of congestion may increase if further upgrades to QNI are shown to be economically justified (refer to Section 7.3.2).

The 2020 ISP identified a Central to Southern Queensland network project as a Future ISP project with a timing in the mid-2030s, recommending that Powerlink undertake preparatory activities to better inform the optimal timing in future revisions of the ISP.

#### **Possible network reinvestments within five years**

Network reinvestments in Wide Bay zone are related to addressing the risks arising from the condition of the existing network assets, which without corrective action, would result in Powerlink being exposed to breaching a number of its jurisdictional network, safety, environmental and Rules' obligations.

By addressing the condition of these existing assets, Powerlink is seeking to ensure it can safely deliver an adequate, economic, and reliable supply of electricity to meet the load requirements of customers in the Wide Bay zone into the future. This may result in like-for-like replacement, non-network solutions, network reconfiguration, asset retirement, line refit or replacement with an asset of lower capacity.

#### **Transmission Lines**

##### **Potential consultation: Maintaining reliability of supply between central and southern Queensland**

The coastal CQ-SQ transmission network between Calliope River and South Pine substations was progressively developed in the 1970s and 1980s to support loads in the Gladstone area and facilitate power transfer between central and southern Queensland. This corridor provides the major injection points at Gin Gin, Teebar Creek, Woolooga and Palmwoods 275/132kV for the Wide Bay and Sunshine Coast areas. The Ergon Energy 132kV and Energex 132/110kV sub-transmission systems supply bulk supply points in these areas.

The coastal CQ-SQ transmission network assets are expected to reach the end of their technical service life within the next 20 years. A key consideration is that this corridor is comprised solely of single circuit 275kV towers that may make cost effective refit strategies less viable compared to double circuit tower rebuilds.

#### **Project driver:**

Emerging condition and compliance risks related to structural corrosion.

With varying distance from the ocean, and localised industrial pollution, the Calliope River to South Pine 275kV single circuit transmission lines are subject to different environmental and atmospheric conditions and have, over time, experienced structural degradation at different rates.

Emerging condition and compliance risks have been identified on the following assets:

##### *Within the next five years:*

- Three 275kV single circuit transmission lines from Calliope River to Wurdong Tee built in 1972, 1976 and 1981 (structural repair due to above ground corrosion)
- One 275kV single circuit transmission line from Woolooga to South Pine built in 1972 (structural repair due to above ground corrosion)

##### *Within the next six to 10 years:*

- One 275kV single circuit transmission lines from Woolooga to Gin Gin built in 1972 (structural repair due to above ground corrosion)
- Three 275kV single circuit transmission lines from Wurdong Tee to Gin Gin built in 1972, 1976 and 1981 (structural repair due to above ground corrosion)
- One 275kV single circuit transmission line form South Pine to Palmwoods built in 1976 (structural repair due to above ground corrosion)



# 5 Future network development

**Project timing: December 2024 to December 2029**

## **Possible network solutions**

The current long-term network solution strategy based on existing network topology and requirements, is to rebuild two of the 275kV single circuit transmission lines from Calliope River to South Pine as a double circuit. The third circuit between Calliope and Woolooga substations is expected to be economic to maintain in the medium term through targeted refit, and if this circuit is dismantled in the longer term, supply to Wurdong from Calliope River via a dedicated 275kV double circuit would need to be established. This strategy will be commercially assessed and adjusted to align with future generation and network developments, in particular if further planning analysis identify triggers to increase capacity or alternative network configuration options.

Strategies to address the transmission line sections with advanced corrosion in the five-year outlook will be commercially assessed in consideration of long-term options for reconfiguring the 275kV transmission lines. The longer term network solution options include:

- network rationalisation (potentially three single circuits to one double circuit) involving a staged program of line rebuild of the coastal corridor as a new double circuit 275kV transmission line at the end of the technical service life of the existing circuits;
- network rationalisation (potentially three single circuits to one double circuit) involving a staged rebuild of the coastal corridor as a new double circuit 275kV transmission line at the end of the technical service life of the existing circuits, using a program of targeted line refits to defer rebuild of individual CQ-SQ sections (where this deferral is economic)
- maintaining the existing three single circuit 275kV transmission lines through a combination of stage rebuild and line refit projects; or
- network rationalisation (potentially three single circuits to one double circuit in sections) of the coastal corridor involving staged line refit and rebuild on the coastal corridor, and reinforcement of the CQ-SQ section via reinforcement of the western CQ-SQ transmission corridor.

## **Proposed network solution within the next 10 years:**

- Rebuild of the two of the three single circuit transmission lines between Calliope River and Wurdong Tee as a double circuit at an estimated cost of \$27 million by June 2024.
- Line refit works on the remaining single circuit 275kV transmission line between Calliope River Substation and Wurdong Tee at an estimated cost of \$6 million by June 2026.
- Targeted refit of the three single circuit transmission lines between Calliope River (Wurdong Tee) and Gin Gin substations at an estimated cost of \$75 million by December 2027.
- Line refit works on the 275kV transmission single circuit transmission line between Woolooga and South Pine substations at an estimated cost of \$20 to \$30 million by June 2026.

Powerlink considers the proposed network solution will not have a material inter-network impact.

## **Possible non-network solutions**

The coastal CQ-SQ transmission network provides essential supply between the generation in central and north Queensland and the loads in southern Queensland. Powerlink would consider proposals from non-network providers that can significantly contribute to reducing the requirement in this region, as this may present opportunities in reconfiguring the network that would otherwise not be able to meet Powerlink's planning standard. Non-network solutions may include, but are not limited to local generation or DSM initiatives in the area.

Powerlink considers that a non-network solution may have material intra-regional and other impacts.

**Possible network reinvestments in the Wide Bay zone within five years<sup>18</sup>**

Against the backdrop of a rapidly changing electricity sector, Powerlink’s planning overview (10-year outlook period of the TAPR) includes consideration of a broad range of options to address the identified needs in the Wide Bay zone. As assets approach their anticipated end of technical service life, the potential projects and alternatives (options) listed in Table 5.18 will be subject to detailed planning to confirm alignment with future reinvestment, optimisation and delivery strategies. This near-term analysis provides Powerlink with an additional opportunity to assess the needs and timing of asset replacement works and deliver greater benefits to customers. This will be achieved through improving and further refining options or considering other options, including the associated delivery strategies, from those described in Table 5.18. Information in relation to potential projects, alternatives and possible commissioning needs will be revised annually within the TAPR based on the latest information available at the time.

**Table 5.18** Possible network reinvestments in the Wide Bay zone within five years

Potential project	High level scope	Purpose	Possible commissioning date	Alternatives	Indicative cost
Transmission lines					
Rebuild of the transmission line between Calliope River Substation and the Wurdong Tee (I)	New double circuit transmission line for the first 15km out of Calliope River substation	Maintain supply reliability to the CQ-SQ transmission corridor (and Gladstone zone)	June 2024	Refit the two single circuit 275kV transmission lines	\$27m
Line refit works on the 275kV transmission line between Calliope River Substation and Wurdong Tee (I)	Refit the single circuit 275kV transmission line between Calliope River Substation and Wurdong Tee	Maintain supply reliability in the CQ-SQ transmission corridor (and Gladstone zone)	June 2026	Rebuild the 275kV transmission line as a double circuit	\$6m
Line refit works on the 275kV transmission line between Woolooga and South Pine substations	Refit the 275kV transmission line between Woolooga and South Pine substations	Maintain supply reliability to the Moreton zone	June 2026	Rebuild the 275kV transmission line between Woolooga and South Pine substations	\$20m to \$30m

Note:

- (I) These reinvestments have been combined into one template “Targeted reinvestment in the 275kV transmission line between Calliope River and (Wurdong Tee) Wurdong substations”.

**Possible network reinvestments within six to 10 years**

As a result of the annual planning review, Powerlink has identified that the following reinvestments are likely to be required to address the risks arising from network assets reaching end of technical service life and to maintain reliability of supply in the Wide Bay zone from around 2026/27 to 2030/31 (refer to Table 5.19).

<sup>18</sup> Subject to the outcome of a regulatory consultation, one of the proposed solutions to address voltage limitations in SE Queensland involves the installation of bus reactors at multiple locations in the transmission network, including one at Woolooga Substation (refer to Section 5.7.10).

## 5 Future network development

**Table 5.19** Possible network reinvestments in the Wide Bay zone within six to 10 years

Potential project	High level scope	Purpose	Possible commissioning date	Alternatives	Indicative cost
Transmission lines					
Targeted reinvestment in the 275kV transmission lines between Wurdong Tee and Gin Gin substation	Refit the 275kV transmission line between Wurdong Tee and Gin Gin Substation	Maintain supply to the Wide Bay zone	December 2027	Targeted Refit and partial double circuit rebuild of the 275kV transmission line between Wurdong Tee and Gin Gin Substation  New 275kV DCST transmission line	\$75m
Line refit works on the 275kV transmission line between South Pine and Palmwoods substations	Line refit works on steel lattice structures	Maintain supply to the Wide Bay zone	June 2028	Rebuild 275kV transmission line between South Pine and Palmwoods substations	\$12m
Line refit works on the 275kV transmission line between Gin Gin and Woolooga substations	Rebuild the 275kV transmission line between Gin Gin and Woolooga substations	Maintain supply to the Wide Bay zone	December 2030	Refit the 275kV transmission line between Gin Gin and Woolooga substations	\$21m
Substations					
Palmwoods 275kV and 132kV selective primary plant replacement	Selective replacement of 275/132kV primary plant	Maintain supply to the Wide Bay zone	June 2028	Full replacement of 275/132kV primary plant	\$15m
Teebar Creek secondary systems replacement	Full replacement of 132kV and 275kV secondary systems	Maintain supply to the Wide Bay zone	June 2028	Selective replacement of 132kV and 275kV secondary systems	\$18m
Woolooga 275kV and 132kV selective primary plant and secondary systems replacement	Selective replacement of 275/132kV primary plant and full replacement of 132kV and 275kV secondary systems (including SVC)	Maintain supply to the Wide Bay zone	June 2029	Selective replacement of 132kV and 275kV secondary systems	\$38m
Gin Gin 275kV secondary systems replacement	Selective replacement of 275kV secondary systems	Maintain supply to the Wide Bay zone	June 2031	Full replacement of 275kV secondary systems	\$10m

**Possible asset retirements within the 10-year outlook period**

Current planning analysis has not identified any potential asset retirements in the Wide Bay zone within the next 10 years.

**5.7.7 South West zone**

**Existing network**

The South West zone is defined as the Tarong and Middle Ridge areas west of Postman's Ridge (refer to Figure 5.10).

**Figure 5.10** South West area 275kV network

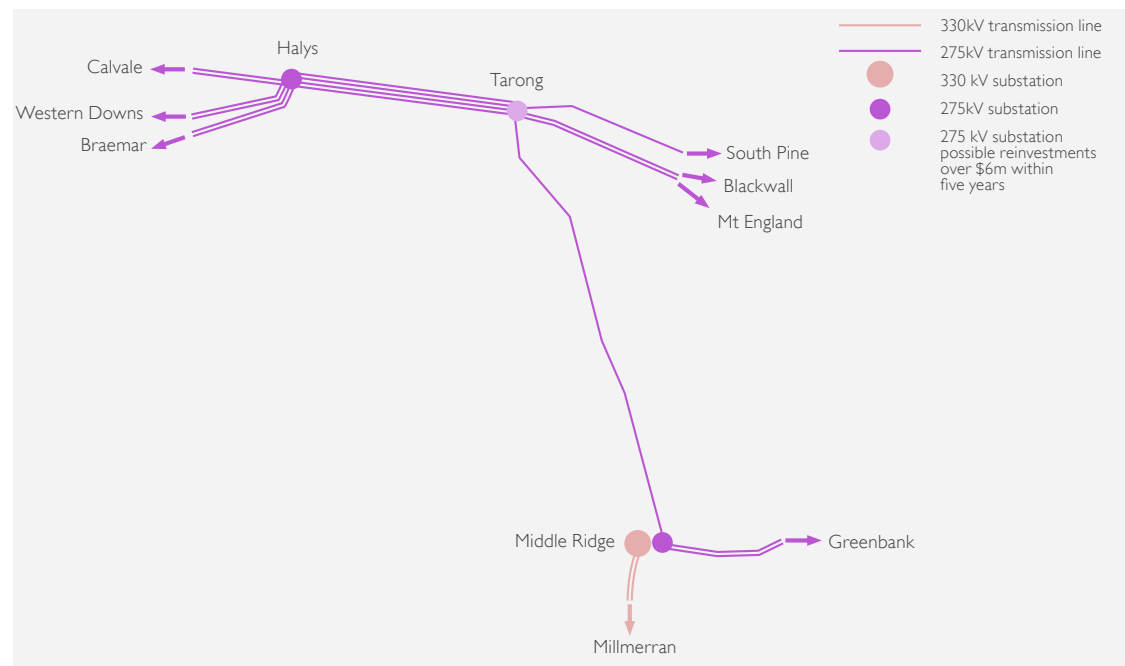

**Possible load driven limitations**

Based on AEMO's Central scenario forecast discussed in Chapter 2, there is no additional capacity forecast to be required as a result of network limitations in the South West zone within the next five years to meet reliability obligations.

**Possible network reinvestments within five years**

Network reinvestments in South West zone are related to addressing the risks arising from the condition of the existing network assets, which without corrective action, would result in Powerlink being exposed to breaching a number of its jurisdictional network, safety, environmental and Rules' obligations.

By addressing the condition of these existing assets, Powerlink is seeking to ensure it can safely deliver an adequate, economic, and reliable supply of electricity to meet the load requirements of customers in the South West zone into the future. This may result in like-for-like replacement, non-network solutions, network reconfiguration, asset retirement, line refit or replacement with an asset of lower capacity.

**Substations**

**Chinchilla 132kV Substation<sup>19</sup>**

Chinchilla Substation was commissioned in 1986 to supply bulk electricity to the distribution network in the area and is supplied via double circuit 132kV transmission lines from Tarong and Columboola substations.

<sup>19</sup> While Chinchilla Substation is not located within the South West zone, as part of Powerlink's integrated planning approach to a RIT-T the benefits of a potential network reconfiguration will be undertaken.

# 5 Future network development

## Project driver:

Emerging condition and compliance risks.

Chinchilla's secondary systems and the majority of primary plant at Chinchilla Substation are approaching the end of their respective technical lives. The substation's secondary systems and circuit breakers have become obsolete and are no longer supported by the manufacture, with only limited spares available.

## Project timing: June 2024

### Possible network solutions

- Replace all primary plant and secondary systems at Chinchilla substation
- Transformer-ending the Chinchilla Substation with supply from the Surat Basin network, decommissioning selected primary plant at Chinchilla and reconfiguring the substation's secondary systems

*Proposed network solution: Transformer ending Chinchilla substation from Columboola substation at an estimated cost of \$8 million by June 2024*

### Possible non-network solutions

Potential non-network solutions would need to provide supply to the 132kV network at Chinchilla of up to 25MW and up to 400MWh per day. The non-network solution would be required for a contingency and to be able to operate on a continuous basis until normal supply is restored. Supply would also be required for planned outages.

## Tarong 275kV Substation

Tarong Substation is located in the South West Queensland transmission network and is a critical part of the 275kV network supplying South East Queensland (SEQ). Located approximately 130km north-west of Brisbane, Tarong Substation is a major part of the 275kV transmission backbone connecting generators to the major load centres in the south-east of the State. It also provides the major injection point for local, rural and bulk mining loads in south-west Queensland.

The Tarong Substation was established in conjunction with the Tarong Power Station in 1982. The substation consists of one switchyard of 275kV operating voltage and one switchyard of 132kV and 66kV operating voltages. Powerlink owns the 275kV, 132kV and 66kV assets on site.

*Potential consultation: Maintaining reliability of supply in the Tarong and Chinchilla areas*

## Project driver:

Emerging condition and compliance risks.

Emerging risks arising from the condition of the existing 275/66kV and 275/132kV transformers at Tarong Substation. All four transformers are nearing the end of their respective service lives, with recent condition assessments revealing a range of increasing network and safety risks arising from their continued operation. The fault level rating of these original transformers is also below the present fault level of the substation and operational constraints are required to manage this following a credible contingency event under particular network conditions.

## Project timing: June 2024

### Possible network solutions

- Maintain network topology by replacement of the two 275/66kV and two 275/132kV transformers
- Network reconfiguration by replacement of the two 275/66kV and decommissioning the two 275/132kV transformers
- Network reconfiguration by replacement of the two 275/66kV and one 275/132kV transformers (while decommissioning the other)
- Network reconfiguration by replacement of both 275/132kV and decommissioning the two 275/66kV transformers and replacing with two 132/66kV transformers

*Proposed network solution: Network reconfiguration by replacement of the two 275/66kV transformers at an estimated cost of \$16 million by June 2024. The two 275/132kV transformers are to be decommissioned.*

#### Possible non-network solutions

To replace the functionality of one of the existing transformers, a non-network solution would be required to provide up to 50MW and up to 850MWh per day on a continuous basis following an outage of the transformer, and to be in-service within six hours following a contingency to meet the requirements of Powerlink's reliability criteria. The network support would also be required to provide supply for planned outages.

The non-network solution must also be able to provide auxiliary supply to Tarong Power Station, which can be up to 38MW.

#### Possible network reinvestments in the South West zone within five years

Against the backdrop of a rapidly changing electricity sector, Powerlink's planning overview (10-year outlook period of the TAPR) includes consideration of a broad range of options to address the identified needs in the South West zone. As assets approach their anticipated end of technical service life, the potential projects and alternatives (options) listed in Table 5.20 will be subject to detailed planning to confirm alignment with future reinvestment, optimisation and delivery strategies. This near-term analysis provides Powerlink with an additional opportunity to assess the needs and timing of asset replacement works and deliver greater benefits to customers. This will be achieved through improving and further refining options or considering other options, including the associated delivery strategies, from those described in Table 5.20. Information in relation to potential projects, alternatives and possible commissioning needs will be revised annually within the TAPR based on the latest information available at the time.

**Table 5.20** Possible network reinvestments in the South West zone within five years

Potential project	High level scope	Purpose	Possible commissioning date	Alternatives	Indicative cost
Substations					
Chinchilla 132kV substation replacement (3)	Selected replacement of 132kV secondary systems and transformer ending from Columboola	Maintain supply reliability in the South West zone	June 2024 (1)	Replacement of the entire 132kV secondary systems and switchyard (2)	\$8m
Tarong 275/66kV transformers replacement	Replacement of 275/66kV transformers and decommissioning the 275/132kV transformers at Tarong Substation (3)	Maintain supply reliability in the South West zone	December 2024	Life extension of existing transformers (2)	\$16m
Tarong 275kV primary plant replacement	Selected replacement of 275kV primary plant	Maintain supply reliability in the South West zone	June 2025	Full replacement of 275kV primary plant	\$2m

Notes:

- (1) Based on the most recent analysis and understanding of the risks arising from the condition of the primary plant at Chinchilla Substation, the proposed network solution has been advanced from the possible commissioning date of December 2026 as advised in the 2019 TAPR.
- (2) The envelope for non-network solutions is defined in Section 5.7.7.
- (3) Operational works, such as asset retirements, do not form part of Powerlink's capital expenditure budget.

## 5 Future network development

### *Possible network reinvestments within six to 10 years*

As a result of the annual planning review, Powerlink has identified that the following reinvestments are likely to be required to address the risks arising from network assets reaching end of technical service life and to maintain reliability of supply in the South West zone from around 2026/27 to 2030/31 (refer to Table 5.21).

**Table 5.21** Possible network reinvestments in the South West zone within six to 10 years

Potential project	High level scope	Purpose	Possible commissioning date	Alternatives	Indicative cost
Substations					
Middle Ridge 275kV and 110kV secondary systems replacement	Selective replacement of 275kV and 110kV secondary systems	Maintain supply reliability in the South West zone	December 2026	Full replacement of 275kV and 110kV secondary systems	\$38m
Oakey 110kV secondary systems replacement	Full replacement of 110kV secondary systems	Maintain supply reliability in the South West zone	June 2029	Staged replacement of 110kV secondary system	\$3m
Tarong 275kV secondary systems replacement	Selective replacement of 275kV secondary systems	Maintain supply reliability in the South West zone	June 2030	Full replacement of 275kV secondary systems	\$16m

### *Possible asset retirements within the 10-year outlook period<sup>20</sup>*

Condition assessment has identified emerging condition risks arising from the condition of two 275/132kV transformers at Tarong Substation by 2024. Planning studies have confirmed the potential to subsequently retire both transformers based on AEMO's Central scenario forecast discussed in Chapter 2. Consequently, it is considered likely the 275/132kV transformers at Tarong Substation will be retired at end of technical service life.

Condition assessment has identified emerging condition risks arising from the condition of 132kV primary plant at Chinchilla Substation by 2024. At this time, an option would be a reduced scope replacement that would involve transformer ending from Columboola 132kV Substation, and retirement of the 132kV primary plant arising from the connection to Tarong Substation.

### 5.7.8 Surat zone

#### Existing network

The Surat Basin zone is defined as the area north west of Western Downs Substation. The area has significant development potential given the vast reserves of gas and coal and more recently VRE. Electricity demand in the area is forecast to continue to grow due to new developments of VRE projects, coal seam gas (CSG) upstream processing facilities by multiple proponents, together with the supporting infrastructure and services (refer to Figure 5.11).

<sup>20</sup> Operational works, such as asset retirements, do not form part of Powerlink's capital expenditure budget.

Figure 5.11 Surat Basin North West area transmission network

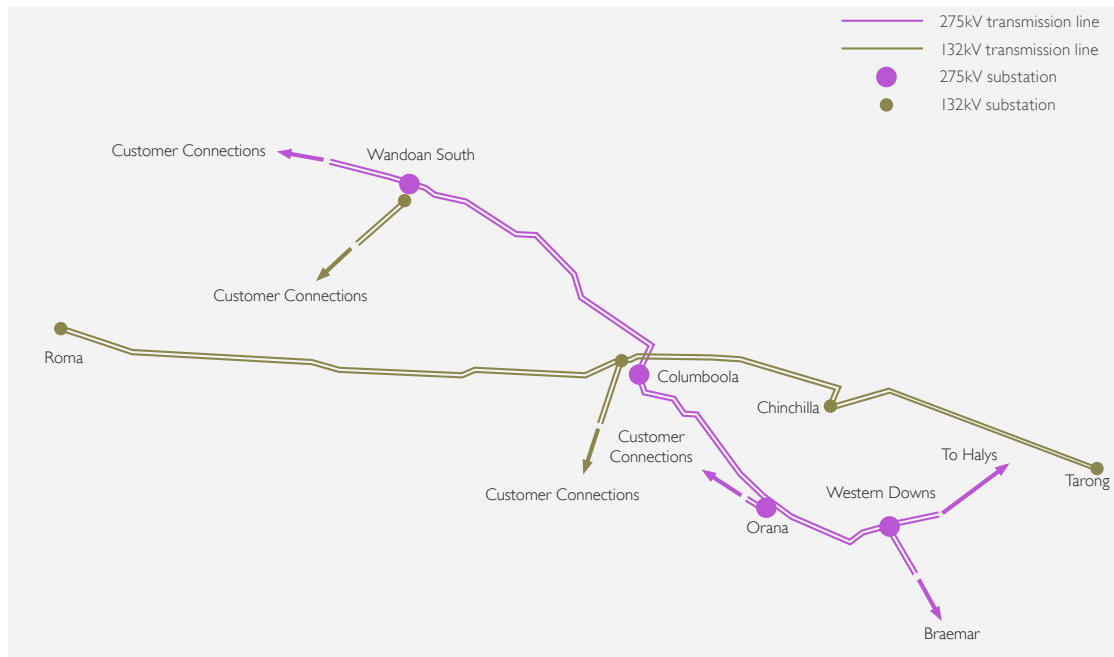

**Possible load driven limitations**

Based on AEMO’s Central scenario forecast discussed in Chapter 2, there is no additional capacity forecast to be required as a result of network limitations in the Surat zone within the next five years to meet reliability obligations.

**Possible network reinvestments within the 10-year outlook period**

Against the backdrop of a rapidly changing electricity sector, Powerlink’s planning overview (10-year outlook period of the TAPR) includes consideration of a broad range of options to address the identified needs in the Surat zone. As assets approach their anticipated end of technical service life, the potential projects and alternatives (options) listed in Table 5.21 will be subject to detailed planning to confirm alignment with future reinvestment, optimisation and delivery strategies. This near-term analysis provides Powerlink with an additional opportunity to assess the needs and timing of asset replacement works and deliver greater benefits to customers. This will be achieved through improving and further refining options or considering other options, including the associated delivery strategies, from those described in Table 5.21. Information in relation to potential projects, alternatives and possible commissioning needs will be revised annually within the TAPR based on the latest information available at the time.

As a result of the annual planning review, Powerlink has identified that the following reinvestments are likely to be required to address the risks arising from network assets reaching end of technical service life and to maintain reliability of supply in the Surat zone towards the end of the 10-year outlook period, from around 2026/27 to 2030/31 (refer to Table 5.22).

Table 5.22 Possible network reinvestments in the Surat zone within six to 10 years

Potential project	High level scope	Purpose	Possible commissioning date	Alternatives	Indicative cost
<b>Substations</b>					
Columboola 132kV secondary system replacement	Selective replacement of 132kV secondary systems	Maintain supply reliability in the Surat zone	June 2031	Full replacement of secondary systems	\$15m



## 5 Future network development

### *Possible asset retirements within the 10-year outlook period*

Current planning analysis has not identified any potential asset retirements in the South West zone within the 10-year outlook period.

### 5.7.9 Bulli zone

#### Existing network

The Bulli zone is defined as the area surrounding Goondiwindi and the 275/330kV network south of Kogan Creek and west of Millmerran (refer to Figure 5.12).

Figure 5.12 Bulli area transmission network

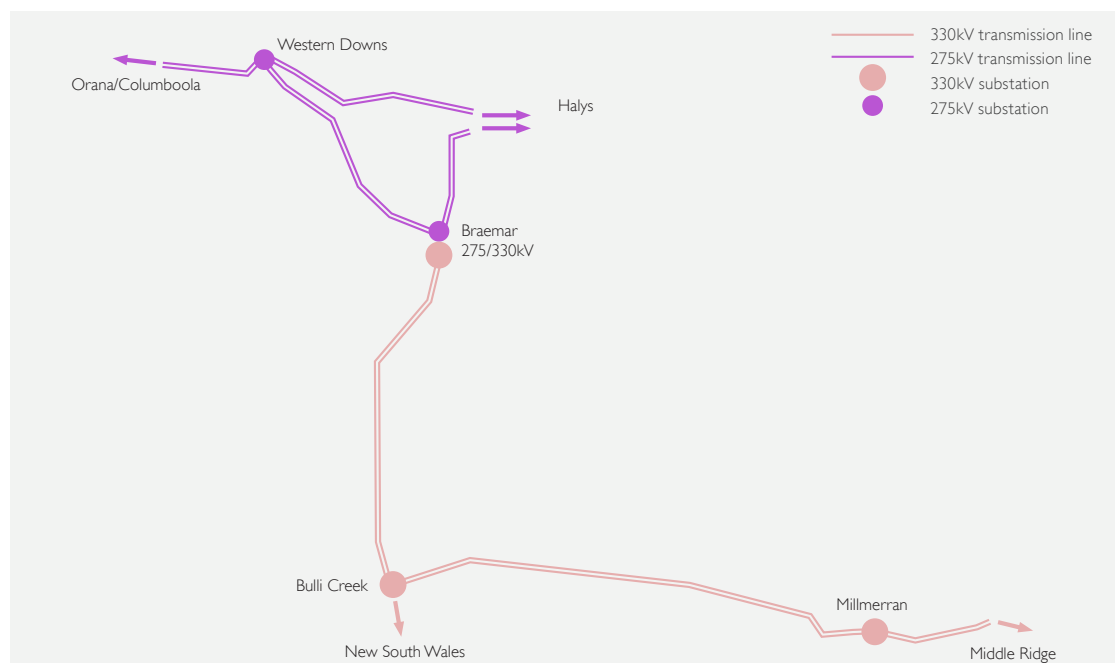

#### *Possible load driven limitations*

Based on AEMO's Central scenario forecast discussed in Chapter 2, there is no additional capacity forecast to be required as a result of network limitations in the Bulli zone within the next five years to meet reliability obligations.

#### *Possible network reinvestments in the Bulli zone within five years*

Against the backdrop of a rapidly changing electricity sector, Powerlink's planning overview (10-year outlook period of the TAPR) includes consideration of a broad range of options to address the identified needs in the Bulli zone. As assets approach their anticipated end of technical service life, the potential projects and alternatives (options) listed in Table 5.23 will be subject to detailed planning to confirm alignment with future reinvestment, optimisation and delivery strategies. This near-term analysis provides Powerlink with an additional opportunity to assess the needs and timing of asset replacement works and deliver greater benefits to customers. This will be achieved through improving and further refining options or considering other options, including the associated delivery strategies, from those described in Table 5.23. Information in relation to potential projects, alternatives and possible commissioning needs will be revised annually within the TAPR based on the latest information available at the time.

Network reinvestments in the Bulli zone are related to addressing the risks arising from the condition of the existing network assets, which without corrective action, would result in Powerlink being exposed to breaching a number of its jurisdictional network, safety, environmental and Rules' obligations.

By addressing the condition of these existing assets, Powerlink is seeking to ensure it can safely deliver an adequate, economic, and reliable supply of electricity to meet the load requirements of customers in the North zone into the future. This may result in like for like replacement, non-network solutions, network reconfiguration, asset retirement, line refit or replacement with an asset of lower capacity.

**Table 5.23** Possible network reinvestments in the Bulli zone within five years<sup>21</sup>

Potential project	High level scope	Purpose	Possible commissioning date	Alternatives	Indicative cost
Substations					
Millmerran 330kV secondary systems replacement	Selective replacement of 330kV secondary systems	Maintain supply reliability in the Bulli zone	June 2025	Full replacement of secondary systems	\$5m

**Possible network reinvestments within six to 10 years**

As a result of the annual planning review, Powerlink has identified that the following reinvestments are likely to be required to address the risks arising from network assets reaching end of technical service life and to maintain reliability of supply in the Bulli zone from around 2026/27 to 2030/31 (refer to Table 5.24).

**Table 5.24** Possible network reinvestments in the Bulli zone within six to 10 years

Potential project	High level scope	Purpose	Possible commissioning date	Alternatives	Indicative cost
Substations					
Bulli Creek 330/132kV transformer replacement	Replace one 330/132kV transformer at Bulli Creek Substation	Maintain supply reliability in the Bulli zone	June 2031	Retirement of 330/132kV transformers with non-network support	\$7m

**Possible asset retirements within the 10-year outlook period**

Current planning analysis has not identified any potential asset retirements in the Bulli zone within the 10-year outlook period.

**5.7.10 Moreton zone**

**Existing network**

The Moreton zone includes a mix of 110kV and 275kV transmission networks servicing a number of significant load centres in SEQ, including the Sunshine Coast, greater Brisbane, Ipswich and northern Gold Coast regions (refer to Figure 5.13).

Future investment needs in the Moreton zone are substantially arising from the condition and performance of 110kV and 275kV assets in the greater Brisbane area. The 110kV network in the greater Brisbane area was progressively developed from the early 1960s and 1970s, with the 275kV network being developed and reinforced in response to load growth from the early 1970s. Multiple Powerlink 275/110kV injection points now interconnect with the Energex network to form two 110kV rings supplying the Brisbane Central Business District (CBD).

<sup>21</sup> Based on the most recent condition assessment and on the scope of works required, Bulli Creek 132kV secondary systems replacement listed in the 2019 TAPR will be addressed by an operational project.

# 5 Future network development

Figure 5.13 Greater Brisbane transmission network

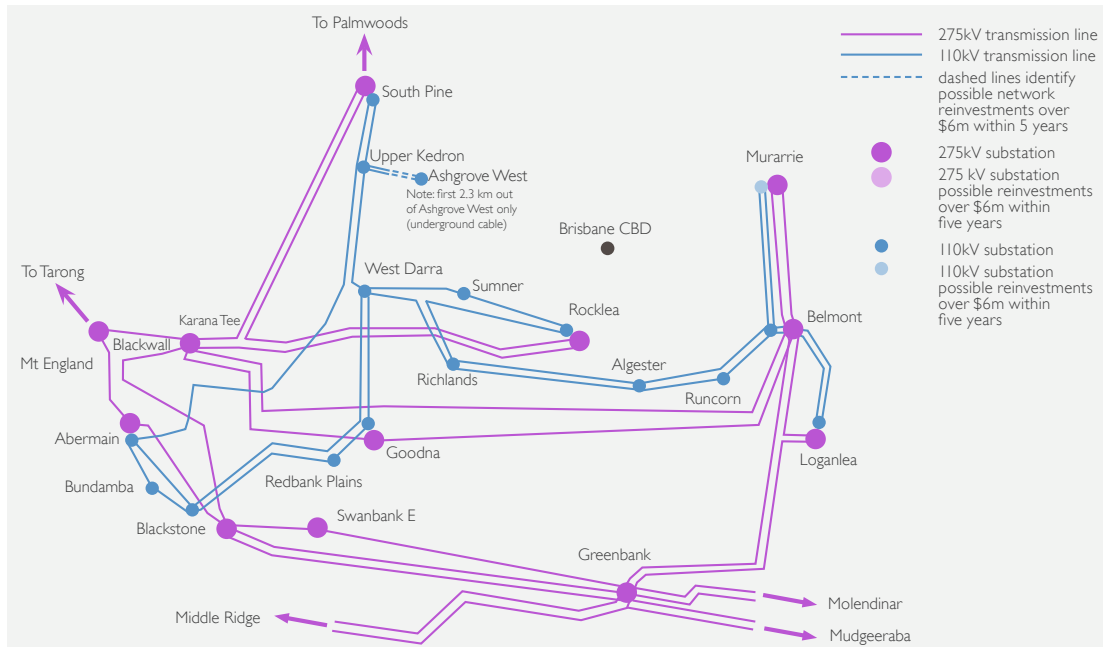

### Possible load driven limitations

Based on AEMO's Central scenario forecast discussed in Chapter 2 and the committed generation described in tables 6.1 and 6.2, there is no additional capacity forecast to be required in the Moreton zone within the next five years to meet reliability obligations.

### Possible network investments to address non-load driven network constraints in the next five years

#### Potential consultation: Managing voltages in south-east Queensland

High voltages associated with light load conditions are currently managed in south-east Queensland with existing reactive sources and operational methods. Voltage control is forecast to become increasingly challenging for longer durations, as minimum demand continues to fall.

#### Project driver:

Voltage control during light load conditions.

Powerlink has identified a need for additional reactive support, to:

- Maintain voltages within operational and design limits during minimum demand periods, to maintain the power system in a secure operating state
- Reduce reliability and system strength impacts from the de-energisation of transmission lines

**Project timing: December 2023**

**Possible network solutions**

- Installation of three bus reactors, one each at Woolooga, Blackstone and Greenbank substations.
- Installation of three bus reactors, one each at Woolooga, Blackstone and Belmont substations.

*Proposed network solution: Installation of three bus reactors, one each at Woolooga, Blackstone and Greenbank substations, at an estimated cost of \$27 million by December 2023*

Powerlink considers the proposed network solution will not have a material inter-network impact.

**Possible non-network solutions**

To address the requirement, Powerlink would be seeking additional voltage control in SEQ which is able to provide sufficient voltage control to various locations in the Moreton region. The nature of this limitation is that the voltage control would be required to operate on a continuous basis.

**Possible network reinvestments within five years**

Network reinvestments in Moreton zone are related to addressing the risks arising from the condition of the existing network assets, which without corrective action, would result in Powerlink being exposed to breaching a number of its jurisdictional network, safety, environmental and Rules' obligations.

By addressing the condition of these existing assets, Powerlink is seeking to ensure it can safely deliver an adequate, economic, and reliable supply of electricity to meet the load requirements of customers in the Moreton zone into the future. This may result in like-for-like replacement, non-network solutions, network reconfiguration, asset retirement, line refit or replacement with an asset of lower capacity.

**Transmission lines**

The 110kV and 275kV transmission lines in the greater Brisbane area are located between 20km and 40km from the coast, traversing a mix of industrial, high density urban and semi-urban areas. The majority of assets are reasonably protected from the prevailing coastal winds and are exposed to moderate levels of pollution related to the urban environment. These assets have, over time, experienced structural corrosion at similar rates, with end of technical service life for most transmission line assets expected to occur towards to end of the 2020s and into the early 2030s.

With the maximum demand forecast relatively flat in the next five years, and based on the development of the network over the last 40 years, planning studies have identified a number of 110kV transmission line assets that could potentially be retired. Given the uncertainty in future demand growth, Powerlink proposes to implement low cost maintenance strategies to keep the transmission lines in-service for a reasonable period. Future decommissioning remains an option once demand growth is better understood.

Detailed analysis will be ongoing to evaluate the possible retirement of the following transmission lines at the end of technical service life:

- West Darra to Upper Kedron
- West Darra to Goodna
- Richlands to Algester.

This ongoing review, together with further joint planning with Energex, may result in a future RIT-T in the late 2020s.

# 5 Future network development

## Underground 110kV cable between Upper Kedron and Ashgrove West

*Potential consultation: Maintain reliability of supply to the Brisbane metropolitan area*

The 110kV transmission line between Upper Kedron and Ashgrove West substations was established in 1978, as one of the principle sources of supply to the north-west Brisbane area. Predominantly an overhead transmission line, with the final 2.3km long section to Ashgrove West Substation being an underground cable.

### Project driver:

Emerging condition, end of technical service life and compliance risks for the Upper Kedron to Ashgrove West oil-filled underground cables.

**Project timing: June 2026**

### Possible network solutions

- Replacement of the existing cables with new cables in a new easement by June 2026.
- Replacement of existing cables with new cables in the existing easement by June 2026.

*Proposed network solution: Replacement of the oil-filled cables with new cables in a new easement at an estimated cost of \$13 million by June 2026*

Powerlink considers the proposed network solution will not have a material inter-network impact.

### Possible non-network solutions

The Upper Kedron to Ashgrove West cables provide supply of up to 220MW at peak to Brisbane's inner north-west suburbs. Powerlink would consider proposals from non-network providers that can significantly contribute to reducing the requirement in this region, as this may present opportunities in reconfiguring the network that would otherwise not be able to meet Powerlink's planning standard. Non-network solutions may include, but are not limited to local generation or DSM initiatives in the area.

## Substations

### Redbank Plains 110kV Substation

*Potential consultation: Maintaining power transfer capability and reliability of supply at Redbank Plains Substation*

Redbank Plains Substation was established to provide electricity to the expanding communities west of Brisbane in 1986 and serves as a bulk supply injection point to the Energex distribution network.

### Project driver:

Addressing the 110kV primary plant condition risks.

**Project timing: June 2024**

### Possible network solutions

- Replacement of selected 110kV primary plant by June 2024
- Full replacement of 110kV primary plant by June 2024

### Project driver:

Emerging condition driven risks arising from the condition of the existing 110/11kV transformers.

Redbank Plains 110/11kV 25MVA transformers 1 and 2 were installed onsite in 1985 and 1984 respectively. The transformers exhibit aged paper insulation and increased moisture levels in oil, possibly due to the numerous oil leaks from the main tanks. The high voltage bushings are the original porcelain housed oil insulated paper bushings, which have been in-service well past their technical service life.

**Project timing: June 2024**

### Possible network solutions

- Life extend both 11/11kV transformers by June 2024
- Replace/life extend one 110/11kV transformer and engage non-network support by June 2024

*Proposed network solution: Replacement of selected 110kV primary plant and life extension of both 110/11kV transformers at Redbank Plains Substation at an estimated cost of \$8 million by June 2024.*

Powerlink considers the proposed network solution will not have a material inter-network impact.

**Possible non-network solutions**

Potential non-network solutions would need to provide supply to the 11kV network at Redbank Plains of up to 25MW at peak and up to 400MWh per day. The non-network solution would be required for a contingency and to be able to operate on a continuous basis until normal supply is restored. Supply would also be required for planned outages.

**Murarrie 275/110kV Substation secondary systems replacements**

Murarrie Substation was established in 2003 as a bulk supply point to service the industrial load around the Brisbane River and port areas. Murarrie secondary systems were commissioned between 2003 and 2006.

*Anticipated consultation: Addressing the secondary systems condition risks at Murarrie*

**Project driver:**

Emerging condition and compliance risks arising from the 110kV secondary systems at Murarrie Substation.

**Project timing: June 2025**

**Possible network solutions**

- Full replacement of all of the 110kV secondary systems upfront by June 2025
- Staged replacement on 110kV secondary systems by June 2025

*Proposed network solution: Full replacement of the 110kV secondary systems at Murarrie Substation at an estimated cost of \$21 million by June 2025*

Powerlink considers the proposed network solution will not have a material inter-network impact.

**Possible non-network solutions**

Murarrie Substation provides injection and switching to the CBD and south-eastern suburbs of Brisbane of over 300MW at peak. Powerlink would consider proposals from non-network providers that can significantly contribute to reducing the requirement in this region, as this may present opportunities in reconfiguring the network that would otherwise not be able to meet Powerlink's planning standard. Non-network solutions may include, but are not limited to local generation or DSM initiatives in the area.

**Ashgrove West 110kV Substation**

Ashgrove West Substation was established in 1979 to meet increased demand in the Brisbane CBD and the expanding residential areas to the north and west of Brisbane.

*Anticipated consultation: Addressing the secondary systems condition risks at Ashgrove West*

**Project driver:**

Emerging condition and compliance risks arising from the 110kV secondary systems at Ashgrove West Substation.

**Project timing: June 2025**

**Possible network solutions**

- Full replacement of all of the 110kV secondary systems upfront by June 2025
- Staged replacement on 110kV secondary systems by June 2025

*Proposed network solution: Full replacement of the 110kV secondary systems at Ashgrove West Substation at an estimated cost of \$6 million by June 2025*

Powerlink considers the proposed network solution will not have a material inter-network impact.

# 5 Future network development

## **Possible non-network solutions**

Ashgrove West is a key substation and part of the network supplying of up to 220MW at peak to Brisbane's inner north-west suburbs. Powerlink would consider proposals from non-network providers that can significantly contribute to reducing the requirement in this region, as this may present opportunities in reconfiguring the network that would otherwise not be able to meet Powerlink's planning standard. Non-network solutions may include, but are not limited to local generation or DSM initiatives in the area.

## ***Possible network reinvestments in the Moreton zone within five years***

Against the backdrop of a rapidly changing electricity sector, Powerlink's planning overview (10-year outlook period of the TAPR) includes consideration of a broad range of options to address the identified needs in the Moreton zone. As assets approach their anticipated end of technical service life, the potential projects and alternatives (options) listed in Table 5.25 will be subject to detailed planning to confirm alignment with future reinvestment, optimisation and delivery strategies. This near-term analysis provides Powerlink with an additional opportunity to assess the needs and timing of asset replacement works and deliver greater benefits to customers. This will be achieved through improving and further refining options or considering other options, including the associated delivery strategies, from those described in Table 5.25 Information in relation to potential projects, alternatives and possible commissioning needs will be revised annually within the TAPR based on the latest information available at the time.

**Table 5.25** Possible network reinvestments in the Moreton zone within five years

Potential project	High level scope	Purpose	Possible commissioning date	Alternatives	Indicative cost
<b>Transmission Lines</b>					
Replacement of the 110kV underground cable between Upper Kedron and Ashgrove West substations	Replace the 110kV underground cable between Upper Kedron and Ashgrove West substations using an alternate easement	Maintain supply reliability in the Moreton zone	June 2026 (1)	Replace the 110kV underground cable between Upper Kedron and Ashgrove West substations using the existing easement (2)	\$13m
<b>Substations</b>					
South-east Queensland bus reactors	Install 275kV bus reactors at Woolooga, Blackstone and Greenbank substations	Maintain system voltages within limits	December 2023	Install 275kV bus reactors at Woolooga, Blackstone and Belmont Substations  Non-network solution yielding the same voltage control capacity (2)	\$27m
Redbank Plains 110kV primary plant and 110/11kV transformers replacement	Selective replacement of 110kV primary plant and life extension of two 110/11kV transformers	Maintain reliability of supply at Redbank Plains Substation	June 2024	Full replacement of 110kV primary plant, replace one 110/11kV transformer and engage non-network support (2)	\$8m (3)
Ashgrove West 110kV secondary systems replacement	Full replacement of 110kV secondary systems	Maintain supply reliability in the Moreton zone	June 2025 (1)	Staged replacement of 110kV secondary systems (2)	\$6m
Muramie 110kV secondary systems replacement	Full replacement of 110kV secondary systems	Maintain supply reliability in the CBD and Moreton zone	June 2025 (1)	Staged replacement of 110kV secondary systems	\$21m
South Pine 275/110kV transformer life extension	Life extension of a single 275kV/110kV transformer	Maintain supply reliability in the Moreton zone	June 2025 (1)	Retirement of a single 275kV/110kV transformer with non-network support	\$2m

Notes:

- (1) The revised timing from the 2019 TAPR is based upon the latest condition assessment.
- (2) The envelope for non-network solutions is defined in Section 5.7.10.
- (3) Compared to the 2019 TAPR, the change in the estimated cost of the proposed network solution is based upon updated information in relation to the scope of works and the construction costs of recently completed projects.



## 5 Future network development

### *Possible network reinvestments in the Moreton zone within six to 10 years*

As a result of the annual planning review, Powerlink has identified that the following reinvestments are likely to be required to address the risks arising from network assets reaching end of technical service life and to maintain reliability of supply in the Moreton zone from around 2026/27 to 2030/31 (refer to Table 5.26).

**Table 5.26** Possible network reinvestments in the Moreton zone within six to 10 years

Potential project	High level scope	Purpose	Possible commissioning date	Alternatives	Indicative cost
Transmission lines					
Line refit works on the 110kV transmission line between Belmont and Murarrie substations	Line refit works on steel lattice structures	Maintain supply reliability in the Moreton zone	June 2028 (1)	Rebuild the 110kV transmission lines between Belmont and Murarrie substations	\$2m
Line refit works on the 110kV transmission line between Richlands and Algester substations	Refit the 110kV transmission line between Richlands and Algester substations	Maintain supply reliability in the Moreton zone	June 2028 (1)	Potential retirement of the transmission line between Richlands and Algester substations	\$2m
Line refit works on the 110kV transmission line between Blackstone and Abermain substations	Refit the 110kV transmission line between Blackstone and Abermain substations	Maintain supply reliability in the Moreton zone	June 2029 (1)	Rebuild the 110kV transmission line between Blackstone and Abermain substations	\$8m (2)
Line refit works on the 275kV transmission line between Bergins Hill and Karana Downs	Refit the 275kV transmission line between Bergins Hill and Karana Downs substations	Maintain supply reliability in the Moreton zone	June 2030 (1)	Rebuild or replace the transmission line between Bergins Hill and Karana Downs substations	\$4m
Line refit works on the 275kV transmission line between Karana Downs and South Pine	Refit the 275kV transmission line between Karana Downs and South Pine substations	Maintain supply reliability in the Moreton zone	June 2030 (1)	Rebuild the 275kV transmission line between Karana Downs and South Pine substations	\$8m
Line refit works on the 110kV transmission lines between Swanbank, Redbank Plains and West Darra substations	Refit the 110kV transmission lines between Swanbank, Redbank Plains and West Darra substations	Maintain supply reliability in the Moreton zone	June 2030 (1)	Rebuild the 110kV transmission lines between Swanbank, Redbank Plains and West Darra substations	\$11m (2)

**Table 5.26** Possible network reinvestments in the Moreton zone within six to 10 years (*continued*)

Potential project	High level scope	Purpose	Possible commissioning date	Alternatives	Indicative cost
Line refit works on the 275kV transmission line between Bergins Hill, Goodna and Belmont substations	Refit the 275kV transmission line between Bergins Hill, Goodna and Belmont substations	Maintain supply reliability in Moreton zone	December 2030	Rebuild the 275kV transmission line between Bergins Hill, Goodna and Belmont substations	\$36m
Substations					
Goodna 275kV and 110kV secondary systems replacement	Full replacement of 275kV and 110kV secondary systems	Maintain supply reliability in the Moreton zone	December 2026 (1)	Staged replacement of 275kV and 110kV secondary systems	\$16m
Sumner 110kV secondary systems replacement	Full replacement of 110kV secondary systems	Maintain supply reliability in the Moreton zone	June 2027 (1)	Staged replacement of 110kV secondary systems	\$4m
Greenbank SVC and 275kV secondary systems replacement	Full replacement of 275kV SVC and secondary systems	Maintain supply reliability in the Moreton and Gold Coast zones	June 2028 (1)	Staged replacement of 275kV SVC and secondary systems	\$31m
South Pine SVC secondary systems replacement	Full replacement of SVC secondary systems	Maintain supply reliability in the Moreton zone	June 2028 (1)	Staged replacement of SVC secondary systems	\$6m
Algester 110kV secondary systems replacements	Full replacement of 110kV secondary systems	Maintain supply reliability in the Moreton zone	June 2028	Staged replacement of 110kV secondary systems	\$10m
West Darra 110kV secondary systems replacement	Full replacement of 110kV secondary systems	Maintain supply reliability in the Moreton zone	June 2028 (1)	Staged replacement of 110kV secondary systems	\$10m
Rocklea 275/110kV transformer replacement	Replacement of one 275/110kV transformer at Rocklea	Maintain supply reliability in the Moreton zone	June 2028 (1)	Life extension of one 275/110kV transformer at Rocklea	\$6m (2)
Rocklea 110kV primary plant replacement	Full replacement of 110kV primary plant	Maintain supply reliability in the Moreton zone	June 2028(1)	Staged replacement of 110kV primary plant	\$5m (2)
Loganlea 275kV primary plant replacement	Full replacement of 275kV primary plant	Maintain supply reliability in the Moreton zone	June 2028 (1)	Staged replacement of 275kV primary plant	\$5m (2)
Bundamba 110kV secondary systems replacement	Full replacement of 110kV secondary systems	Maintain supply reliability in the Moreton zone	June 2028	Staged replacement of 110kV primary plant	\$6m

## 5 Future network development

**Table 5.26** Possible network reinvestments in the Moreton zone within six to 10 years (*continued*)

Potential project	High level scope	Purpose	Possible commissioning date	Alternatives	Indicative cost
Goodna 110/33kV transformer augmentation	Installation of a 100MVA 110/33kV transformer	Maintain supply reliability in the Moreton zone	June 2029 (1)	Installation of a smaller 110/33kV transformer and non-network support	\$6m
South Pine 275kV primary plant replacement	Staged replacement of 275kV primary plant	Maintain supply reliability in the Moreton zone	June 2030 (1)	Full replacement of 275kV primary plant	\$5m (2)
Abermain 110kV secondary systems and primary plant replacement	Full replacement of 110kV secondary systems and staged replacement of primary plant	Maintain supply reliability in the Moreton zone	June 2030	Staged replacement of 110kV secondary systems and primary plant	\$13m

Notes:

- (1) The revised timing from the 2019 TAPR is based upon the latest condition assessment.
- (2) Compared to the 2019 TAPR, the change in the estimated cost of the proposed network solution is based upon updated information in relation to the scope of works and the construction costs of recently completed projects.

### **Possible asset retirements within the 10-year outlook period**

#### **Loganlea 110/33kV transformer**

Based on the condition of one of the 110/33kV transformers at Loganlea, it is proposed to retire this transformer at the end of technical service life by June 2023. Powerlink considers that this will not impact on the ability to meet the obligations of Powerlink's reliability criteria. Further joint planning will be undertaken prior to a final decision being made.

### **Confirmed asset retirements within the 10-year outlook period**

#### **Belmont 275/110kV transformers**

Based on the condition of the two transformers at Belmont Substation, Powerlink has approved projects to retire two of the four 275/110kV transformers by November 2021.

Since publication of the 2019 TAPR, it has been confirmed that retirement of these transformers will not result in load at risk in the Brisbane area. Powerlink considers the retirement of these two transformers will not have a material inter-network impact or a material impact to network users.

### **5.7.11 Gold Coast zone**

#### **Existing network**

The Powerlink transmission system in the Gold Coast was originally constructed in the 1970s and 1980s. The Molendinar and Mudgeeraba substations are the two major injection points into the area (refer to Figure 5.13) via a double circuit 275kV transmission line between Greenbank and Molendinar substations, and two single circuit 275kV transmission lines between Greenbank and Mudgeeraba substations (refer to Figure 5.14).

Figure 5.14 Gold Coast transmission network

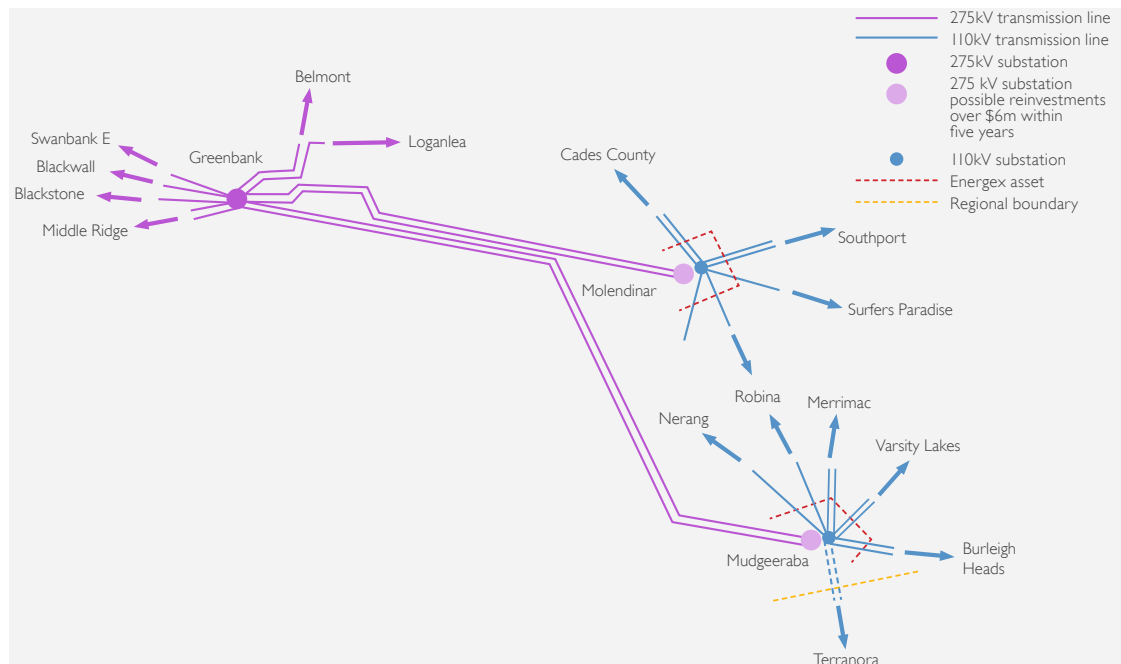

**Possible load driven limitations**

Based on AEMO’s Central scenario forecast discussed in Chapter 2, there is no additional capacity forecast to be required as a result of network limitations in the Gold Coast zone within the next five years to meet reliability obligations.

**Possible network reinvestments within five years**

Network reinvestments in Gold Coast zone are related to addressing the risks arising from the condition of the existing network assets, which without corrective action, would result in Powerlink being exposed to breaching a number of its jurisdictional network, safety, environmental and Rules’ obligations.

By addressing the condition of these existing assets, Powerlink is seeking to ensure it can safely deliver an adequate, economic, and reliable supply of electricity to meet the load requirements of customers in the Gold Coast zone into the future. This may result in like-for-like replacement, non-network solutions, network reconfiguration, asset retirement, line refit or replacement with an asset of lower capacity.

**Transmission lines**

**Greenbank to Mudgeeraba 275kV transmission lines**

*Potential consultation: Maintain reliability of supply to the southern Gold Coast area*

The two 275kV single circuit transmission lines were constructed in the mid-1970s and support the supply to Gold Coast and northern NSW.

**Project driver:**

Emerging condition driven risks related to an unacceptable level of corrosion.

**Project timing: December 2028**

# 5 Future network development

## Possible network solutions

Feasible network solutions to address the risks arising from these transmission lines may include:

- Maintaining the existing 275kV transmission line topography and capacity by way of a targeted line refit by December 2028.
- Replacement at the end of technical service life of the existing single circuits between Mudgeeraba and Greenbank with a new double circuit line, through staged rebuild.
- Decrease in transfer capacity into the Gold Coast and rationalisation of the transmission lines supplying the Gold Coast through a combination of line refit projects and decommissioning of some assets.

*Proposed network solution: Maintain the existing topography by way of a targeted line refit at an estimated cost of \$30 to \$50 million by December 2028*

To ensure reliability of supply to customers, the required renewal works will need to be completed in stages outside of summer peak load and outage co-ordination will be complex due to the significant renewal program in the Gold Coast area within the 10-year outlook. Due to these challenges it has been identified that an extended delivery timeframe of at least four years would be required with the potential for works to commence within the next five years.

Powerlink considers the proposed network solution will not have a material inter-network impact.

## Possible non-network solutions

The Greenbank to Mudgeeraba 275kV transmission lines provide injection to the southern Gold Coast and northern NSW area. Powerlink is not aware of any non-network proposals in this area that can address this requirement in its entirety. Powerlink would consider proposals from non-network providers that can significantly contribute to reducing the requirement in this region, as this may present opportunities in reconfiguring the network that would otherwise not be able to meet Powerlink's planning standard. Non-network solutions may include, but are not limited to local generation or DSM initiatives in the area.

## Substations

### Mudgeeraba 275/110kV Substation

Mudgeeraba 110kV Substation was established in 1972 and extended from the 1980s to 2000s due to load growth and is located within the southern end of zone of the Gold Coast. Further extensions included the establishment of a 275kV switchyard and associated secondary systems in 1992, which was further expanded in 2002. Mudgeeraba 275/110kV Substation is one of two 275kV injection points on the Gold Coast and is a major connection point for supply to the Gold Coast and northern NSW with the 110kV substation supplying distribution points including Robina, Nerang, Broadbeach, Burleigh and Terranora.

### Mudgeeraba 110kV secondary systems

*Potential consultation: Addressing the 110kV secondary systems condition risks at Mudgeeraba*

#### Project driver:

Emerging condition risks arising from the condition of the 110kV secondary systems.

The 110kV secondary systems at Mudgeeraba were commissioned between 2001 and 2004.

#### Project timing: December 2025

## Possible network solutions

- Staged replacement of the secondary systems components by December 2025.
- Full replacement of all secondary systems by December 2025.

*Proposed network solution: Full replacement of secondary systems at an estimated cost of \$11 million by December 2025*

Powerlink considers the proposed network solution will not have a material inter-network impact.

**Possible non-network solutions**

Mudgeeraba Substation provides injection and switching to the southern Gold Coast and northern NSW area. Powerlink would consider proposals from non-network providers that can significantly contribute to reducing the requirement in this region, as this may present opportunities in reconfiguring the network that would otherwise not be able to meet Powerlink's planning standard. Non-network solutions may include, but are not limited to local generation or DSM initiatives in the area.

*Potential consultation: Addressing the 275kV and 110kV primary plant condition risks at Mudgeeraba*

**Project driver:**

Emerging risks arising from the condition of the 275kV and 110kV primary plants.

**Project timing: December 2025****Possible network solutions**

- Selected replacement of primary plant by December 2025.
- Full replacement of all primary plant by December 2025.

*Proposed network solution: selected replacement of primary plant at an estimated cost of \$20 million by December 2025*

Powerlink considers the proposed network solution will not have a material inter-network impact.

**Possible non-network solutions**

Mudgeeraba Substation provides injection and switching to the southern Gold Coast and northern NSW area. Powerlink would consider proposals from non-network providers that can significantly contribute to reducing the requirement in this region, as this may present opportunities in reconfiguring the network that would otherwise not be able to meet Powerlink's planning standard. Non-network solutions may include, but are not limited to local generation or DSM initiatives in the area.

**Molendinar 275/110kV Substation**

The 275kV secondary systems at Molendinar was originally established in 2003 and 2007, and based on the most recent condition assessment since publication of the 2019 TAPR, is expected to reach the end of technical service life within the 10-year outlook (refer to Table 5.28).

**Possible network reinvestments in the Gold Coast zone within five years**

Against the backdrop of a rapidly changing electricity sector, Powerlink's planning overview (10-year outlook period of the TAPR) includes consideration of a broad range of options to address the identified needs in the Gold Coast zone. As assets approach their anticipated end of technical service life, the potential projects and alternatives (options) listed in Table 5.27 will be subject to detailed planning to confirm alignment with future reinvestment, optimisation and delivery strategies. This near-term analysis provides Powerlink with an additional opportunity to assess the needs and timing of asset replacement works and deliver greater benefits to customers. This will be achieved through improving and further refining options or considering other options, including the associated delivery strategies, from those described in Table 5.27. Information in relation to potential projects, alternatives and possible commissioning needs will be revised annually within the TAPR based on the latest information available at the time.

## 5 Future network development

**Table 5.27** Possible network reinvestments in the Gold Coast zone within five years

Potential project	High level scope	Purpose	Possible commissioning date	Alternatives	Indicative cost
Substations					
Mudgeeraba 110kV secondary systems replacement	Partial replacement of 110kV secondary systems	Maintain supply reliability in the Gold Coast zone	December 2025 (1)	Full replacement of 110kV secondary systems	\$11m (2)
Mudgeeraba 275kV and 110kV primary plant replacement	Selected replacement of 110kV and 275kV equipment	Maintain supply reliability in the Gold Coast zone	December 2025	Staged replacement of 110kV primary plant in existing bays and selected 275kV equipment	\$20m

Notes:

- (1) The revised timing from the 2019 TAPR is based upon the latest condition assessment.
- (2) Compared to the 2019 TAPR, the increase in the estimated cost of the proposed network solution is based upon updated information in relation to the construction costs of recently completed projects.

### ***Possible network reinvestments in the Gold Coast zone within six to 10 years***

As a result of the annual planning review, Powerlink has identified that the following reinvestments are likely to be required to address the risks arising from network assets reaching end of technical service life and to maintain reliability of supply in the Gold Coast zone from around 2026/27 to 2030/31 (refer to Table 5.28).

**Table 5.28** Possible network reinvestments in the Gold Coast zone within six to 10 years

Potential project	High level scope	Purpose	Possible commissioning date	Alternatives	Indicative cost
<b>Transmission lines</b>					
Line refit works on the 110kV transmission line between Mudgeeraba Substation and Terranora	Targeted line refit works on steel lattice structures	Maintain supply reliability from Queensland to NSW Interconnector	December 2028 (1)	Full line refit  New transmission line	\$5m
Targeted line refit works on sections of the 275kV transmission line between Greenbank and Mudgeeraba substations	Targeted line refit works on steel lattice structures	Maintain supply reliability in the Gold Coast zone	December 2028 (1)	New double circuit 275kV transmission line	\$30m to \$50m
<b>Substations</b>					
Molendinar 275kV secondary systems replacement	Full replacement of 275kV secondary systems	Maintain supply reliability in the Gold Coast zone	December 2026 (1)	Selected replacement of 275kV secondary systems	\$16m (2)
Mudgeeraba 275/110kV No.1 Transformer Replacement	Replacement of the transformer	Maintain supply reliability to the Gold Coast Region	December 2030	Life extension of the existing transformer	\$10m

Notes:

- (1) Compared to the 2019 TAPR, the change in timing of the network solution is based upon updated information on the condition of the assets.
- (2) Compared to the 2019 TAPR, the increase in the estimated cost of the proposed network solution is based upon updated information in relation to required scope of works.

**Possible asset retirements within the 10-year outlook period**

Current planning analysis has not identified any potential asset retirements in the Gold Coast zone within the 10-year outlook period.

**5.7.12 Supply demand balance**

The outlook for the supply demand balance for the Queensland region was published in the AEMO [2020 Electricity Statement of Opportunity \(ESOO\)](#)<sup>22</sup>. Interested parties who require information regarding future supply demand balance should consult this document.

**5.7.13 Existing interconnectors**

The Queensland transmission network is interconnected to the NSW transmission system through the QNI transmission line and Terranora Interconnector transmission line.

The QNI maximum southerly capability is limited by voltage stability, transient stability, oscillatory stability, and line thermal rating considerations (as detailed in Section 6.6.10).

<sup>22</sup> Published by AEMO in August 2019.



## 5 Future network development

The combined QNI plus Terranora Interconnector maximum northerly capability is limited by thermal ratings, voltage stability, transient stability and oscillatory stability (as detailed in Section 6.6.9).

The capability of these interconnectors can vary significantly depending on the status of plant, network conditions, weather and load levels in both Queensland and NSW. It is for these reasons that interconnector capability is regularly reviewed, particularly when new generation enters or leaves the market or transmission projects are commissioned in either region.

### 5.7.14 Expanding NSW-Queensland transmission transfer capacity

A RIT-T process to consider investment options on the QNI commenced in November 2018 and was completed in December 2019 with the publication of the '[Expanding NSW-Queensland transmission transfer capacity](#)' Project Assessment Conclusion Report (PACR). This RIT-T focussed on consideration of the 2018 ISP recommended Group 1 QNI 'minor' upgrade and investigated the near-term options to increase overall net market benefits in the NEM through relieving congestion on the transmission network between NSW and Queensland. The PACR identified upgrading the Liddell to Tamworth transmission lines, installing new dynamic reactive support at Tamworth and Dumaresq, and shunt capacitor banks at Tamworth, Dumaresq and Armidale as the preferred option which is expected to deliver the greatest net benefits. These works are anticipated to be completed by 2022, prior to the closure of Liddell Power Station.

The 2020 ISP identified further upgrades to the QNI capacity as part of the optimal development path. The 2020 ISP identified that this project would reduce costs and enhance system resilience. The project was not yet identified as 'actionable', but is expected to be so in the future. The proposed project is a staged 500kV line upgrade to share renewable energy, storage, and firming services between the regions after the closure of Eraring or to support REZ developments. Each stage is a 500kV line; the first forecast for completion by 2032-33 and the second by 2035-36.

Given the project is anticipated to become 'actionable' in a future ISP, AEMO is requesting that the inputs for this project (cost and capacity) be updated and refined for input into the 2022 ISP process. To that end AEMO has set out in the 2020 ISP, that Powerlink and TransGrid provide preparatory activities in relation to the future staged QNI project by 30 June 2021. Further to the preparatory activities, Powerlink and TransGrid will investigate the potential benefits of additional increases to transmission capacity between NSW and Queensland, beyond the capacity provided by the QNI Minor Upgrade.

Additional transmission capacity would need to deliver net market benefits, which could come from:

- Efficiently maintaining supply reliability in NSW following the closure of further coal-fired generation and the decline in ageing generator reliability
- Facilitating efficient development and dispatch of generation in areas with high quality renewable resources through improved network capacity and access to demand centres
- Enabling more efficient sharing of resources between NEM regions.

Options to deliver these benefits include:

- A 'Virtual transmission line' (VTL) comprised of grid-scale batteries on both sides of a constraint (for bidirectional limit increases), or a grid-scale battery on one side and braking resistor or generator tripping on the other side (for unidirectional limit increases)
- Transmission lines at 500kV or 330kV from Bayswater, Wollar or Liddell (NSW) to southern Queensland.

These options can be optimised with capacity to REZ developments and can be staged by geography, operating voltage and number of circuits to maximise net economic benefits (refer to Section 7.4.1).

## **CHAPTER 6**

# Network capability and performance

- 6.1 Introduction
- 6.2 Available generation capacity
- 6.3 Network control facilities
- 6.4 Existing network configuration
- 6.5 Transfer capability
- 6.6 Grid section performance
- 6.7 Zone performance

# 6 Network capability and performance

## Key highlights

- Generation commitments since the 2019 Transmission Annual Planning Report (TAPR) add 1,498MW to Queensland's semi-scheduled variable renewable energy (VRE) generation capacity taking the total existing and committed semi-scheduled VRE generation capacity to 3,960MW.
- The Central Queensland to South Queensland (CQ-SQ) grid section was highly utilised during 2019/20, reflecting high generation levels in North Queensland (NQ) as a result of recently commissioned VRE generators.
- Committed generation is expected to continue to alter power transfers, particularly during daylight hours, increasing the likelihood of congestion across the Gladstone, CQ-SQ and Queensland/New South Wales (NSW) Interconnector (QNI) grid sections.
- Record peak transmission delivered demands were recorded in the Central West, Surat and Bulli zones during 2019/20.
- The transmission network has performed reliably during 2019/20, with Queensland grid sections largely unconstrained.

## 6.1 Introduction

This chapter on network capability and performance provides:

- an outline of existing and committed generation capacity over the next three years
- a summary of network control facilities configured to disconnect load as a consequence of noncredible events
- single line diagrams of the existing high voltage (HV) network configuration
- background on factors that influence network capability
- zonal energy transfers for the two most recent years
- historical constraint times and power flow duration curves at key sections of Powerlink Queensland's transmission network
- a qualitative explanation of factors affecting power transfer capability at key sections of Powerlink's transmission network
- historical system normal constraint times and load duration curves at key zones of Powerlink's transmission network
- double circuit transmission lines categorised as vulnerable by the Australian Energy Market Operator (AEMO)
- a summary of the management of high voltages associated with light load conditions.

The capability of Powerlink's transmission network to meet forecast demand is dependent on a number of factors. Queensland's transmission network is predominantly utilised more during summer than winter. During higher summer temperatures, reactive power requirements are greater and transmission plant has lower power carrying capability. Also, higher demands occur in summer as shown in Figure 2.12.

The location and pattern of generation dispatch influences power flows across most of the Queensland network. Future generation dispatch patterns and interconnector flows are uncertain in the deregulated electricity market and will vary substantially due to output of VRE generation and due to the effect of planned or unplanned outages of generation plant. Power flows can also vary substantially with planned or unplanned outages of transmission network elements. Power flows may also be higher at times of local area or zone maximum demands (refer to Table 2.13) and/or when embedded generation output is lower.

The updated release date of the TAPR has allowed reporting to be modified to align with financial years. The reporting in previous TAPRs was based on the April to March of the following year period. Therefore historical figures are not directly comparable with previous editions of the TAPR.

## 6.2 Available generation capacity

Scheduled generation in Queensland is predominantly a combination of coal-fired, gas turbine and hydro-electric generators.

AEMO's definition of 'committed' from the System Strength Impact Assessment Guidelines<sup>1</sup> (effective 1 July 2018) has been adopted for the purposes of this year's TAPR. During 2019/20, commitments have added 1,498MW of capacity, taking Queensland's semi-scheduled VRE generation capacity to 3,960MW. Figure 6.1 illustrates the expected changes to available and committed generation capacity in Queensland from summer 2017/18 to summer 2022/23.

**Figure 6.1** Summer available generation capacity by energy source

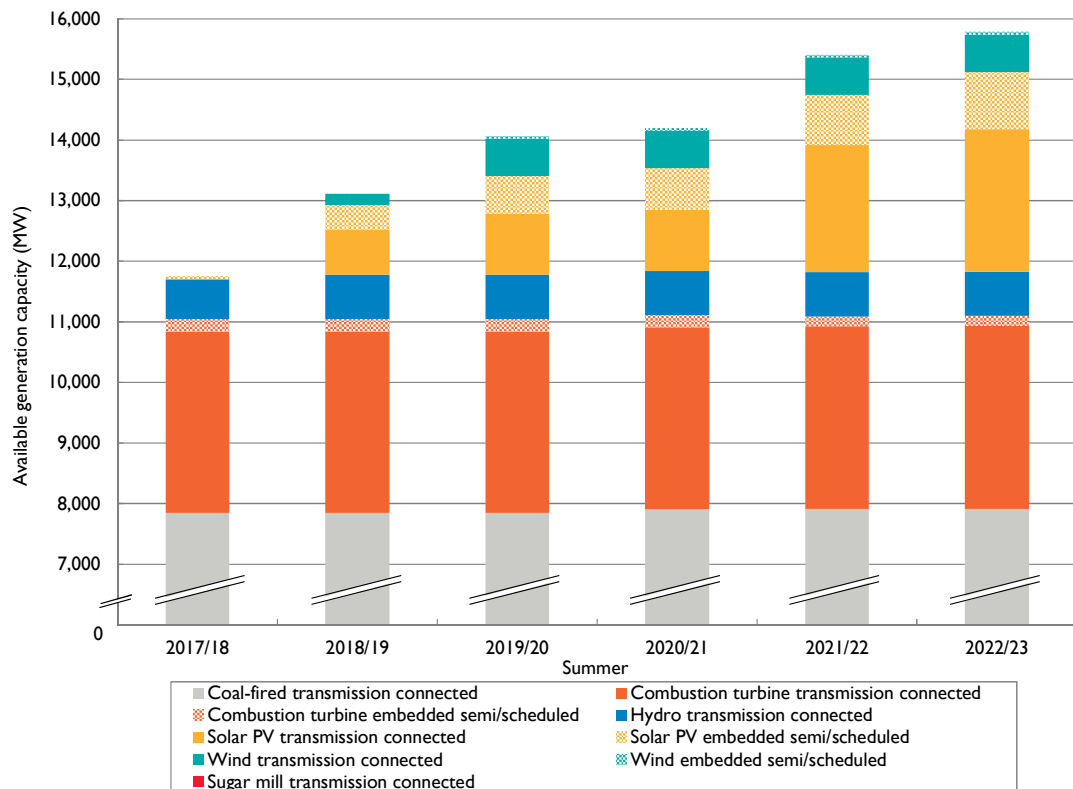

### 6.2.1 Existing and committed transmission connected and direct connect embedded generation

Table 6.1 summarises the available generation capacity of power stations connected, or committed to be connected to Powerlink's transmission network (including the non-scheduled generators at Yarwun, Invicta and Koombaloo) or connected to direct connect customers.

Semi-scheduled transmission connected solar farms Moura, Rodds Bay, Woolooga Energy Park, Bluegrass, Columboola, Gangarri and Western Downs Green Power Hub have reached committed status since the 2019 TAPR.

Information in this Table has been provided to AEMO by the owners of the generators. Details of registration and generator capacities can be found on [AEMO's website](#). In accordance with Clause 5.18A of the National Electricity Rules (NER), [Powerlink's Register of Large Generator Connections](#) with information on generators connected to Powerlink's network can be found on Powerlink's website.

<sup>1</sup> AEMO, [System Strength Impact Assessment Guidelines](#), June 2018.

## 6 Network capability and performance

**Table 6.1** Available generation capacity – existing and committed generators connected to the Powerlink transmission network or direct connect customers

Generator	Location	Available generation capacity (MW) (1)					
		Summer 2020/21	Winter 2021	Summer 2021/22	Winter 2022	Summer 2022/23	Winter 2023
<b>Coal-fired</b>							
Stanwell	Stanwell	1,460	1,460	1,460	1,460	1,460	1,460
Gladstone	Calliope River	1,680	1,680	1,680	1,680	1,680	1,680
Callide B	Calvale	700	700	700	700	700	700
Callide Power Plant	Calvale	840	840	840	840	840	840
Tarong North	Tarong	443	443	443	443	443	443
Tarong	Tarong	1,400	1,400	1,400	1,400	1,400	1,400
Kogan Creek	Kogan Creek PS	709	750	721	750	721	750
Millmerran	Millmerran PS	672	852	672	852	672	852
Total coal-fired		7,904	8,125	7,916	8,125	7,916	8,125
<b>Combustion turbine</b>							
Townsville 132kV	Townsville PS	150	165	150	165	150	165
Mt Stuart	Townsville South	387	400	387	400	387	400
Yarwun (2)	Yarwun	160	155	160	155	160	155
Condamine (3)	Columboola	139	144	139	144	139	144
Braemar 1	Braemar	491	530	491	543	501	543
Braemar 2	Braemar	480	519	480	519	480	519
Darling Downs	Braemar	563	630	563	630	563	630
Oakey (4)	Tangkam	288	346	288	346	288	346
Swanbank E	Swanbank E PS	350	365	350	365	350	365
Total combustion turbine		3,008	3,254	3,008	3,267	3,018	3,267
<b>Hydro-electric</b>							
Barron Gorge	Kamerunga	66	66	66	66	66	66
Kareeya (including Koombooloomba) (5)	Chalumbin	93	93	93	93	93	93
Wivenhoe (6)	Mt. England	570	570	570	570	570	570
Total hydro-electric		729	729	729	729	729	729
<b>Solar PV (7)</b>							
Ross River	Ross	116	116	116	116	116	116
Sun Metals (3)	Townsville Zinc	107	107	107	107	107	107
Haughton	Haughton River	100	100	100	100	100	100
Clare	Clare South	100	100	100	100	100	100
Whitsunday	Strathmore	57	57	57	57	57	57

**Table 6.1** Available generation capacity – existing and committed generators connected to the Powerlink transmission network or direct connect customers (*continued*)

Generator	Location	Available generation capacity (MW) (I)					
		Summer 2020/21	Winter 2021	Summer 2021/22	Winter 2022	Summer 2022/23	Winter 2023
Hamilton	Strathmore	57	57	57	57	57	57
Daydream	Strathmore	150	150	150	150	150	150
Hayman	Strathmore	50	50	50	50	50	50
Rugby Run	Moranbah	65	65	65	65	65	65
Lilyvale	Lilyvale	100	100	100	100	100	100
Moura	Moura			82	82	82	82
Rodds Bay	South of Wurdong				250	250	250
Woolooga Energy Park	Woolooga			176	176	176	176
Bluegrass	Chinchilla			148	148	148	148
Columboola	Columboola		162	162	162	162	162
Gangarri	Wandoan South		120	120	120	120	120
Western Downs Green Power Hub	Western Downs			400	400	400	400
Darling Downs	Braemar	108	108	108	108	108	108
Total solar PV		1,010	1,292	2,098	2,348	2,348	2,348
<b>Wind (7)</b>							
Mt Emerald	Walkamin	180	180	180	180	180	180
Coopers Gap	Coopers Gap	440	440	440	440	440	440
Total wind		620	620	620	620	620	620
<b>Sugar mill</b>							
Invicta (5)	Invicta Mill	0	34	0	34	0	34
Total sugar mill		0	34	0	34	0	34
Total all stations		13,271	14,054	14,371	15,123	14,631	15,123

## 6 Network capability and performance

Notes:

- (1) Synchronous generator capacities shown are at the generator terminals and are therefore greater than power station net sent out nominal capacity due to station auxiliary loads and step-up transformer losses. The capacities are nominal as the generator rating depends on ambient conditions. Some additional overload capacity is available at some power stations depending on ambient conditions.
- (2) Yarwun is a non-scheduled generator, but is required to comply with some of the obligations of a scheduled generator.
- (3) Condamine and Sun Metals are direct connected embedded generators.
- (4) Oakey Power Station is an open-cycle, dual-fuel, gas-fired power station. The generated capacity quoted is based on gas fuel operation.
- (5) Koombooloomba and Invicta are transmission connected non-scheduled generators.
- (6) Wivenhoe Power Station is shown at full capacity (570MW). However, output can be limited depending on water storage levels in the dam.
- (7) VRE generators shown at maximum capacity at the point of connection.

### 6.2.2 Existing and committed scheduled and semi-scheduled distribution connected embedded generation

Table 6.2 summarises the available generation capacity of embedded scheduled and semi-scheduled power stations connected, or committed to be connected to Queensland's distribution network.

Semi-scheduled embedded solar farms Munna Creek and Kingaroy have reached committed status since the 2019 TAPR.

Information in this Table has been provided to AEMO by the owners of the generators. Details of registration and generator capacities can be found on [AEMO's website](#).

**Table 6.2** Available generation capacity – existing and committed scheduled or semi-scheduled generators connected to the Energex and Ergon Energy (part of the Energy Queensland Group) distribution networks.

Generator	Location	Available generation capacity (MW)					
		Summer 2020/21	Winter 2021	Summer 2021/22	Winter 2022	Summer 2022/23	Winter 2023
Combustion turbine (1)							
Townsville 66kV	Townsville PS	78	82	78	82	78	82
Mackay (2)	Mackay	34	34				
Barcaldine	Barcaldine	32	37	32	37	32	37
Roma	Roma	54	68	54	68	54	68
Total combustion turbine		198	221	164	187	164	187
Solar PV (3)							
Kidston	Kidston	50	50	50	50	50	50
Kennedy Energy Park	Hughenden	15	15	15	15	15	15
Collinsville	Collinsville North	42	42	42	42	42	42
Clermont	Clermont	75	75	75	75	75	75
Middlemount	Lilyvale	26	26	26	26	26	26
Emerald	Emerald	72	72	72	72	72	72
Aramara	Aramara			104	104	104	104
Susan River	Maryborough	75	75	75	75	75	75
Childers	Isis	56	56	56	56	56	56
Munna Creek	Kilkivan					120	120
Kingaroy	Kingaroy			40	40	40	40
Maryborough	Yarranlea	27	27	27	27	27	27
Yarranlea	Yarranlea	103	103	103	103	103	103
Oakey 1	Oakey	25	25	25	25	25	25
Oakey 2	Oakey	55	55	55	55	55	55
Warwick	Warwick	64	64	64	64	64	64
Total solar PV		685	685	829	829	949	949
Wind (3)							
Kennedy Energy Park	Hughenden	43	43	43	43	43	43
Total Wind		43	43	43	43	43	43
Total all stations		926	949	1,036	1,059	1,156	1,179



## 6 Network capability and performance

Notes:

- (1) Synchronous generator capacities shown are at the generator terminals and are therefore greater than power station net sent out nominal capacity due to station auxiliary loads and step-up transformer losses. The capacities are nominal as the generator rating depends on ambient conditions. Some additional overload capacity is available at some power stations depending on ambient conditions.
- (2) AEMO's generating unit expected closure year, July 2020 Version, quotes an expected closure date of 1st April 2021 for Mackay GT.
- (3) VRE generators shown at maximum capacity at the point of connection.

### 6.3 Network control facilities

Powerlink participated in the second Power System Frequency Risk Review<sup>2</sup> (PSFRR) in 2020. The PSFRR, as part of the Emergency Frequency Control Schemes (EFCS) rule change<sup>3</sup>, placed an obligation on AEMO to undertake, in collaboration with Transmission Network Service Providers (TNSPs), an integrated, periodic review of power system frequency risks associated with non-credible contingency events.

AEMO published the Final 2020 PSFRR – Stage 1 Report on 31 July 2020. For Queensland, the recommendation involved the expansion of Powerlink's CQ-SQ Special Protection Scheme (SPS). The existing scheme disconnects one or two highest generating Callide units, depending on CQ-SQ transfer, for the unplanned loss of both Calvale to Halys 275kV feeders. The existing scheme is limited to transfers lower than 1,700MW and relies on the ability to disconnect high output generating units. Powerlink has initiated a project to implement new Wide area monitoring protection and control (WAMPAC) architecture into CQ-SQ SPS by mid-2021. The scheme is expected to include approximately 600MW of renewable generators and run along with the existing SPS.

AEMO is considering whether a protected event should be declared to manage residual risk through operational measures. AEMO will be investigating the cost-benefit of this proposal in Stage 2 of the 2020 PSFRR due by the end of 2020.

Stage 2 of the 2020 PSFRR will also review the requirement for an Over Frequency Generation Shedding (OFGS) scheme as part of the QNI upgrade.

Powerlink owns other network control facilities which minimise or reduce the consequences of multiple contingency events. Network control facilities owned by Powerlink which may disconnect load following a multiple non-credible contingency event are listed in Table 6.3.

---

<sup>2</sup> AEMO, [Draft 2020 PSFRR– Stage 1](#), July 2020.

<sup>3</sup> AEMC, [Rule Determination National Electricity Amendment \(Emergency Frequency Control Schemes\) Rule 2017](#), 30 March 2017.

**Table 6.3** Powerlink owned network control facilities configured to disconnect load as a consequence of non-credible events during system normal conditions

Scheme	Purpose
FNQ Under Voltage Load Shed (UVLS) scheme	Minimise risk of voltage collapse in FNQ
North Goonyella Under Frequency Load Shed (UFLS) relay	Raise system frequency
Dysart UVLS	Minimise risk of voltage collapse in Dysart area
Eagle Downs UVLS	Minimise risk of voltage collapse in Eagle Downs area
Boyne Island UFLS relay	Raise system frequency
Queensland UFLS Inhibit Scheme	Minimise risk of QNI separation for an UFLS event for moderate to high southern transfers on QNI compared to Queensland demand
Tarong UFLS relay	Raise system frequency
Middle Ridge UFLS relays	Raise system frequency
Mudgeeraba Emergency Control Scheme (ECS)	Minimise risk of voltage collapse in the Gold Coast zone

## 6.4 Existing network configuration

Figures 6.2, 6.3, 6.4 and 6.5 illustrate Powerlink's network as of July 2020.

# 6 Network capability and performance

Figure 6.2 Existing HV network July 2020 - NQ

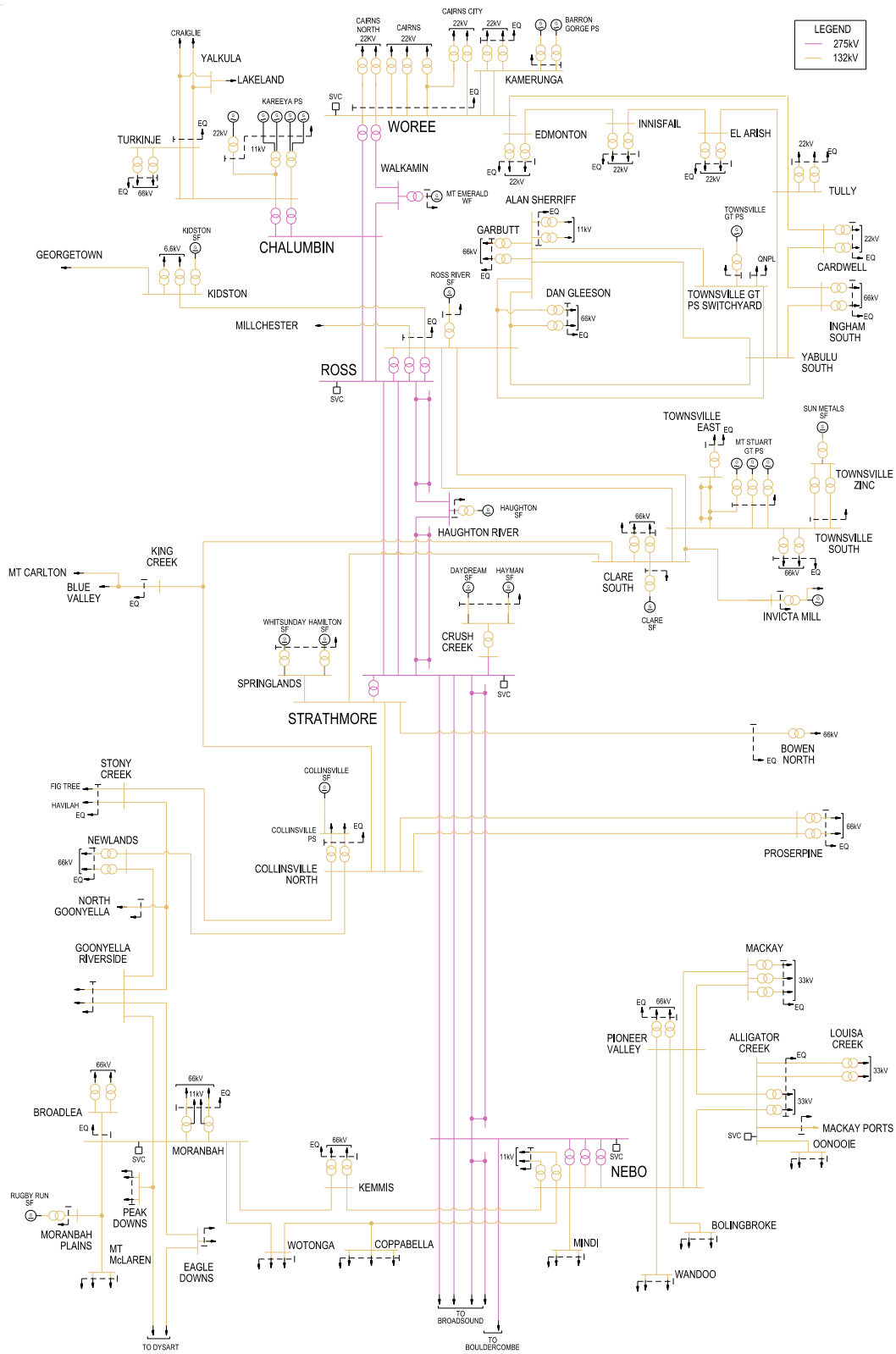
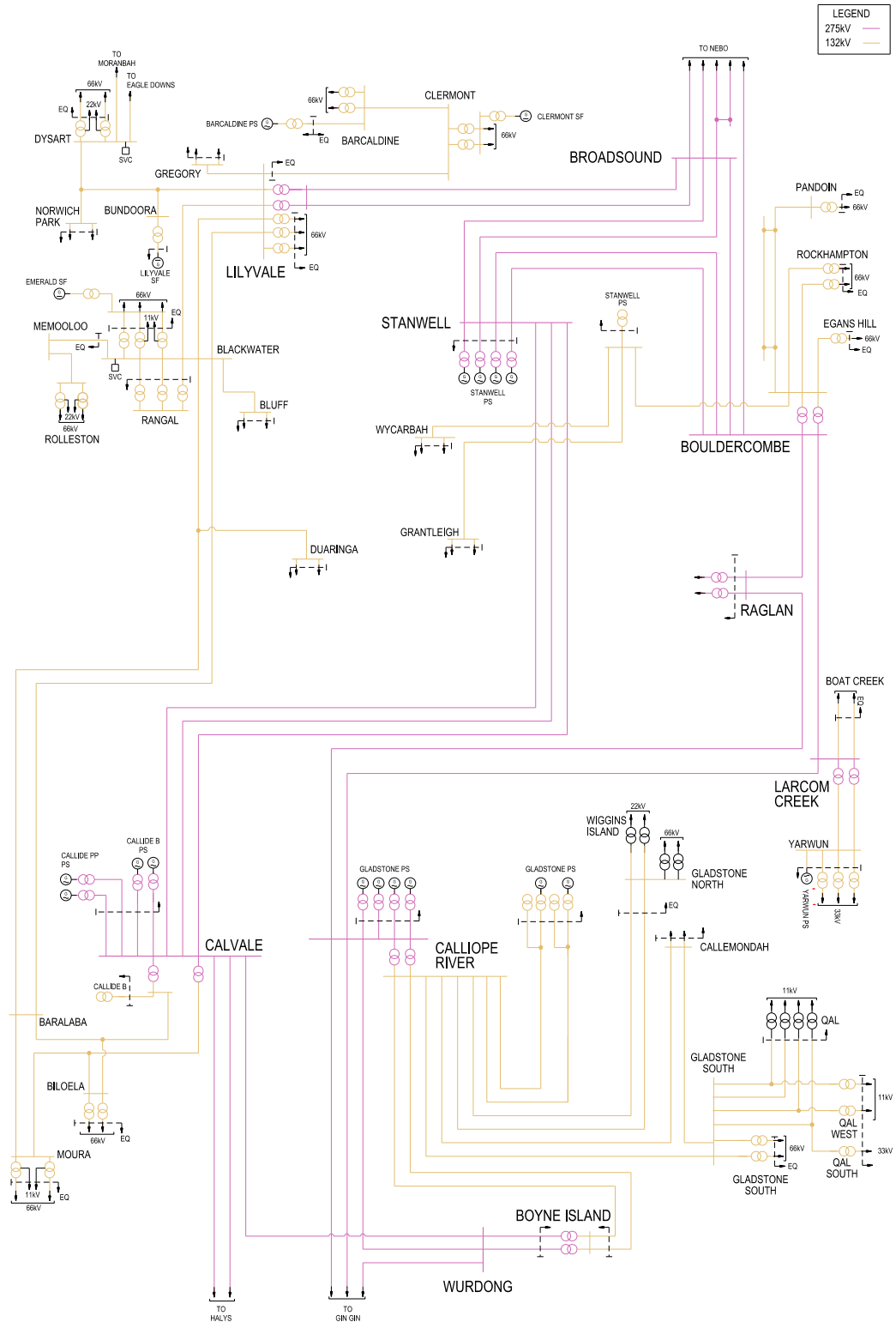

Figure 6.3 Existing HV network July 2020 - CQ



# 6 Network capability and performance

Figure 6.4 Existing HV network July 2020 - South West Queensland

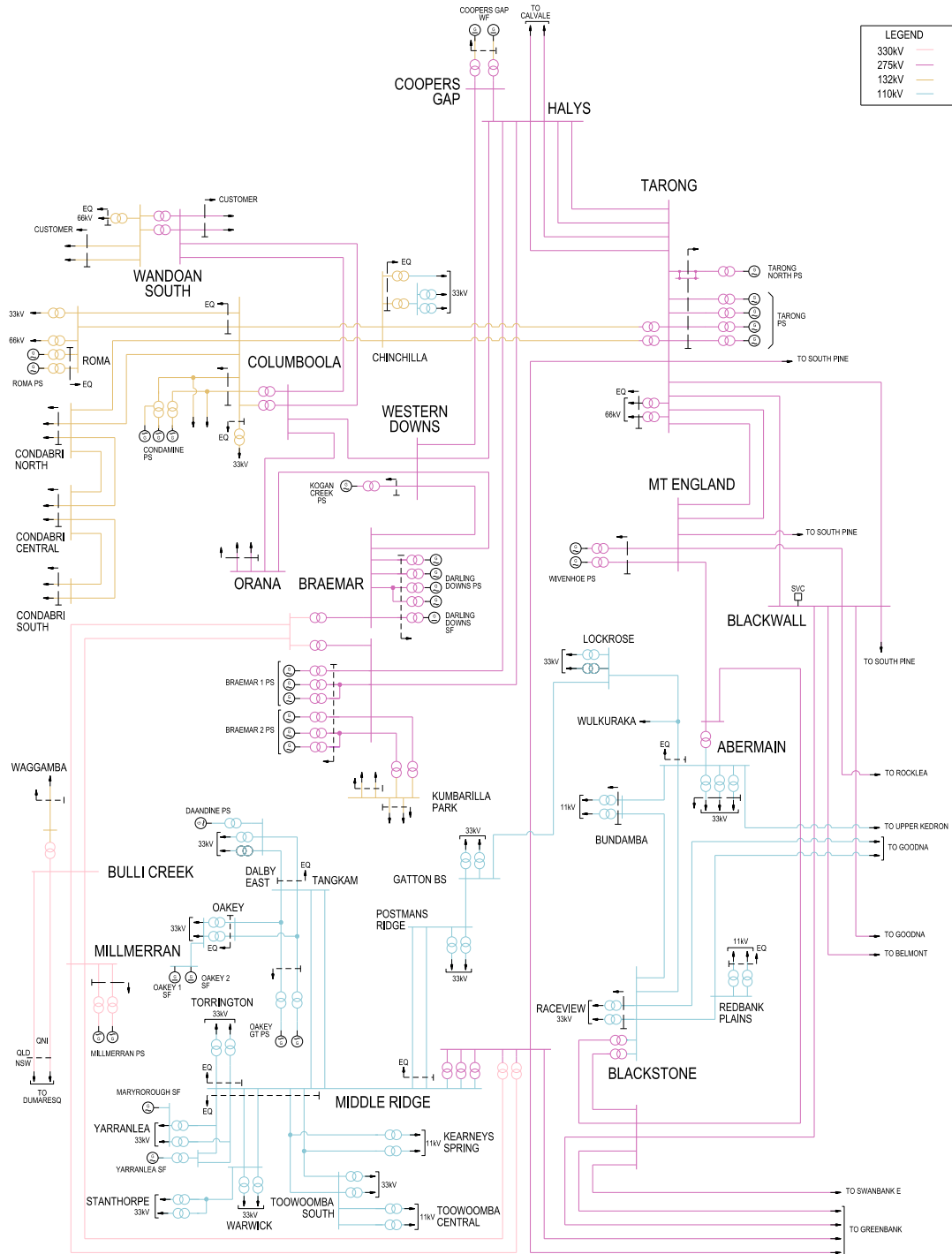
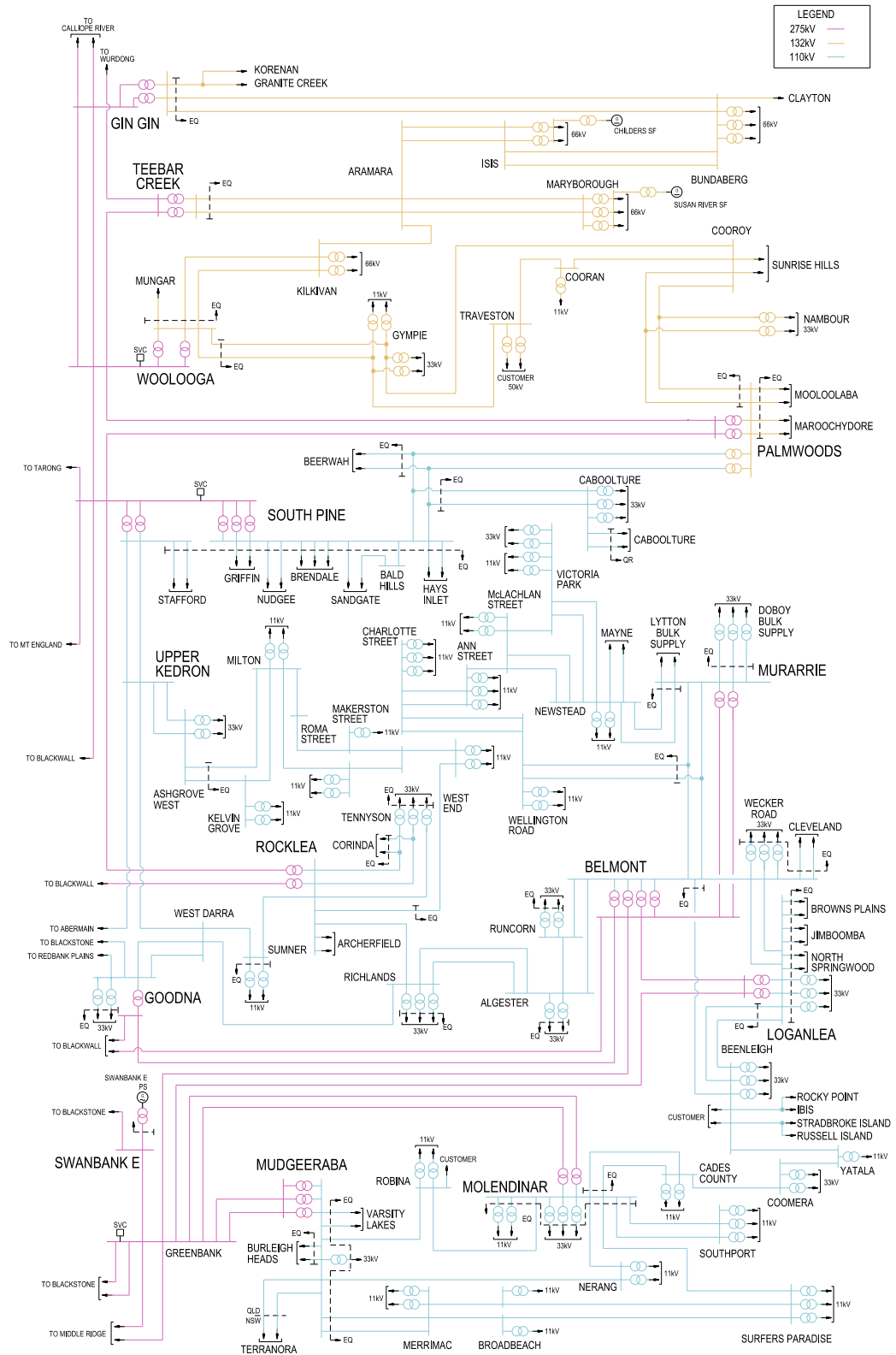

Figure 6.5 Existing HV network July 2020 - South East Queensland



# 6 Network capability and performance

## 6.5 Transfer capability

### 6.5.1 Location of grid sections

Powerlink has identified a number of grid sections that allow network capability and forecast limitations to be assessed in a structured manner. Limit equations have been derived for these grid sections to quantify maximum secure power transfer. Maximum power transfer capability may be set by transient stability, voltage stability, thermal plant ratings or protection relay load limits. AEMO has incorporated these limit equations into constraint equations within the National Electricity Market Dispatch Engine (NEMDE), Table C.2 provides definitions and Figure C.2 in Appendix C shows the location of relevant grid sections on the Queensland network.

### 6.5.2 Determining transfer capability

Transfer capability across each grid section varies with different system operating conditions. Transfer limits in the National Electricity Market (NEM) are not generally amenable to definition by a single number. Instead, TNSPs define the capability of their network using multi-term equations. These equations quantify the relationship between system operating conditions and transfer capability, and are implemented into NEMDE, following AEMO's due diligence, for optimal dispatch of generation. In Queensland the transfer capability is highly dependent on which generators are in-service and their dispatch level. The limit equations maximise transmission capability available to electricity market participants under prevailing system conditions.

Limit equations derived by Powerlink which are current at the time of publication of this TAPR are provided in Appendix D. Limit equations will change over time with demand, generation and network development and/or network reconfiguration. Such detailed and extensive analysis on limit equations has not been carried out for future network and generation developments for this TAPR. However, expected limit improvements for committed works are incorporated in all future planning. Section 6.6 provides a qualitative description of the main system conditions that affect the capability of each grid section.

## 6.6 Grid section performance

This section is a qualitative summary of system conditions with major effects on transfer capability across key grid sections of the Queensland network.

For each grid section, the time that the relevant constraint equations have bound over the last 10 years is provided categorised as occurring during intact or outage conditions based on AEMO's constraint description. Constraint times can be associated with a combination of generator unavailability, network outages, unfavourable dispatches and/or high loads. Constraint times do not include occurrences of binding constraints associated with network support agreements. Binding constraints whilst network support is dispatched are not classed as congestion. Although high constraint times may not be indicative of the cost of market impact, they serve as a trigger for the analysis of the economics for overcoming the congestion.

Binding constraint information is sourced from AEMO. Historical binding constraint information is not intended to imply a prediction of constraints in the future.

Historical transfer duration curves for the last five years are included for each grid section. Grid section transfers are predominantly affected by load, generation and transfers to neighbouring zones. Figures 6.6 and 6.7 provide 2018/19 and 2019/20 zonal energy as generated into the transmission network (refer to Figure C.1 in Appendix C for generators included in each zone) and by major embedded generators, transmission delivered energy to Distribution Network Service Providers (DNSPs) and direct connect customers and grid section energy transfers. Figure 6.8 provides the changes in energy transfers from 2018/19 to 2019/20. These figures assist in the explanation of differences between 2018/19 and 2019/20 grid section transfer duration curves.

Figure 6.6 2018/19 zonal electrical energy transfers (GWh)

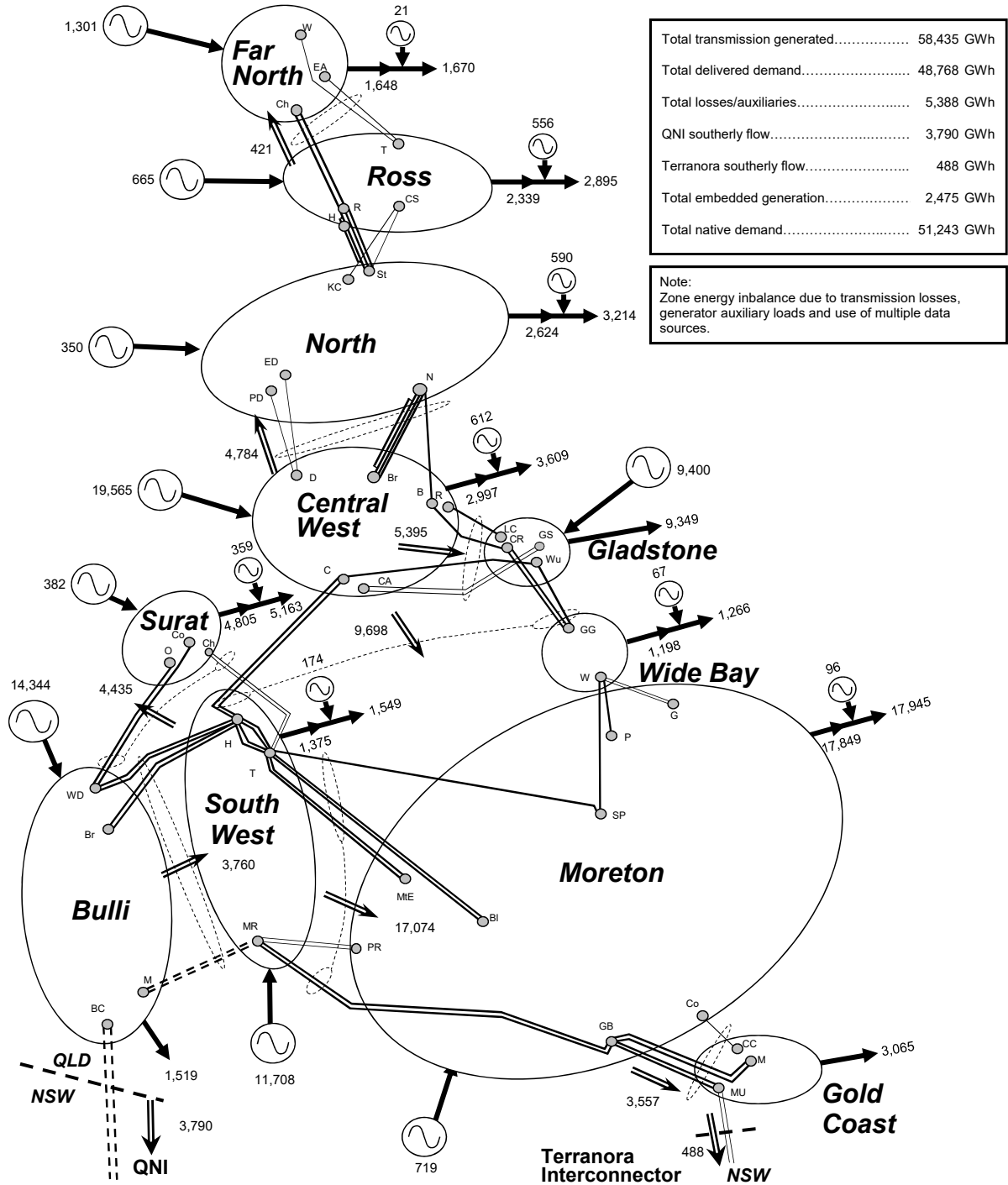



# 6 Network capability and performance

Figure 6.7 2019/20 zonal electrical energy transfers (GWh)

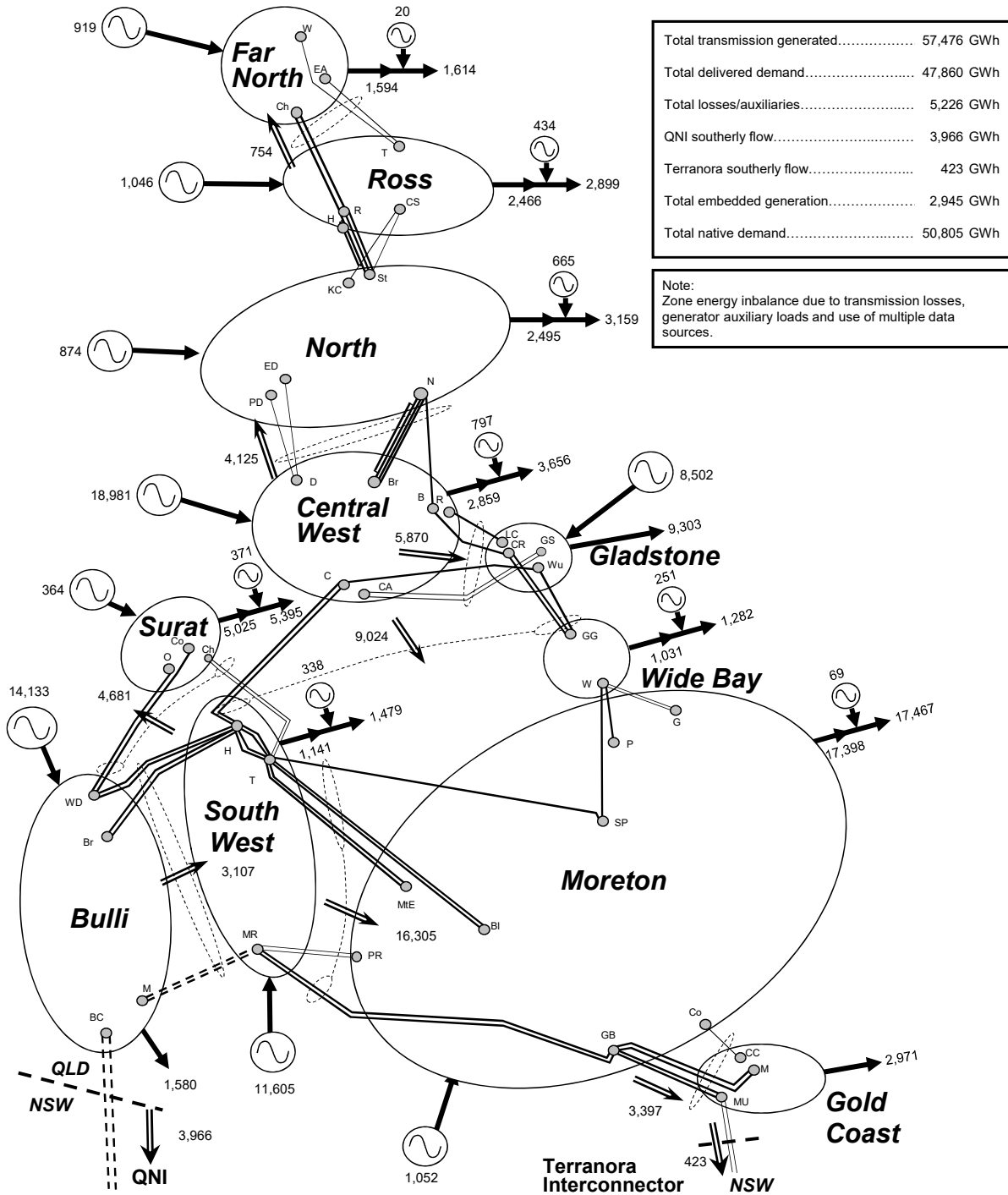
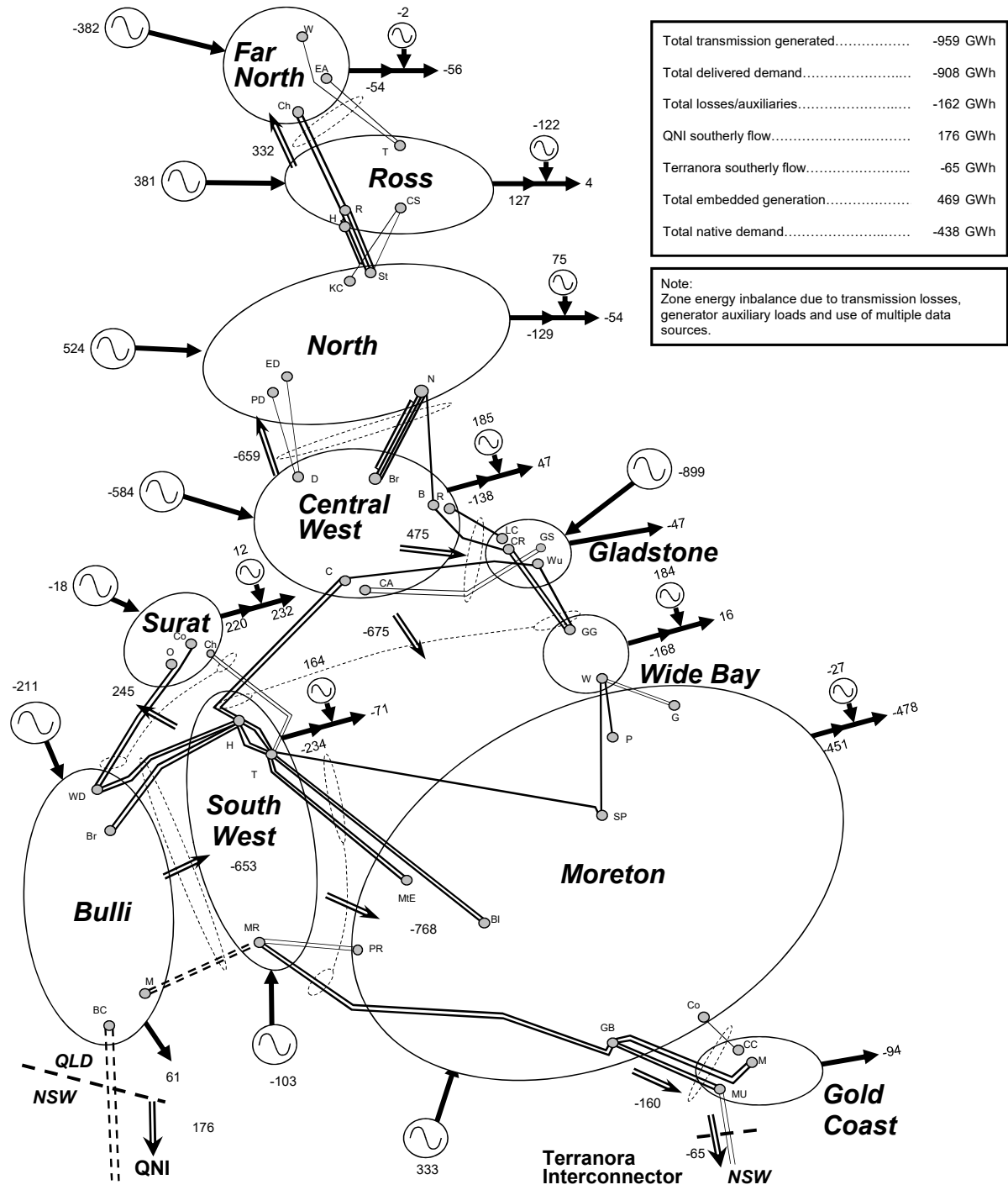

Figure 6.8 Change in zonal electrical energy transfers (GWh)



## 6 Network capability and performance

### 6.6.1 Far North Queensland (FNQ) grid section

Maximum power transfer across the FNQ grid section is set by voltage stability associated with an outage of a Ross to Chalumbin 275kV circuit.

The limit equation in Table D.1 of Appendix D shows that the following variables have a significant effect on transfer capability:

- Far North zone to northern Queensland area<sup>4</sup> demand ratio
- Far North and Ross zones generation.

Local hydro generation reduces transfer capability but allows more demand to be securely supported in the Far North zone. This is because reactive margins increase with additional local generation, allowing further load to be delivered before reaching minimum allowable reactive margins. However, due to its distributed and reactive nature, increases in delivered demand erode reactive margins at greater rates than they were created by the additional local generation. Limiting power transfers are thereby lower with the increased local generation but a greater load can be delivered.

The FNQ grid section did not constrain operation during 2019/20. Information pertaining to the historical duration of constrained operation for the FNQ grid section is summarised in Figure 6.9.

Figure 6.9 Historical FNQ grid section constraint times

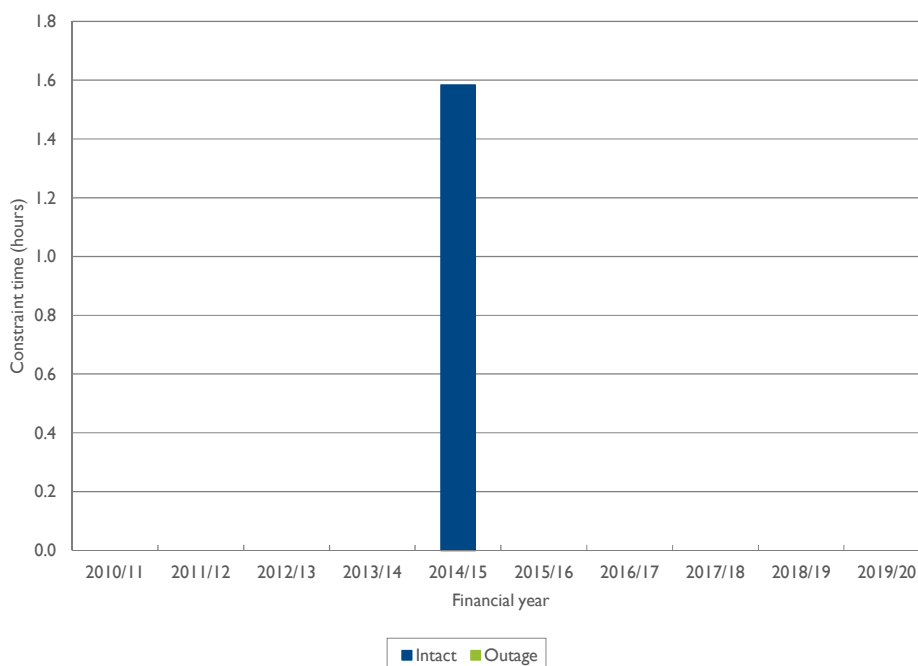

There have been minimal constraints in this grid section since 2010/11.

Figure 6.10 provides historical transfer duration curves showing a large decrease in energy transfer but similar peak transfers over 2019/20. This is predominantly attributed to the commissioned Mount Emerald wind farm located between Chalumbin and Woree substations. Historically, changes in peak flow and energy delivered to the Far North zone by the transmission network have been dependant on the Far North zone load and generation from the hydro generating power stations at Barron Gorge and Kareeya. These vary depending on rainfall levels in the Far North zone. The combined hydro generating power station capacity factor has reduced between 2018/19 and 2019/20 meaning there is still scope for lower northerly energy transfers (refer to figures 6.6, 6.7 and 6.8).

<sup>4</sup> Northern Queensland area is defined as the combined demand of the Far North, Ross and North zones.

**Figure 6.10** Historical FNQ grid section transfer duration curves

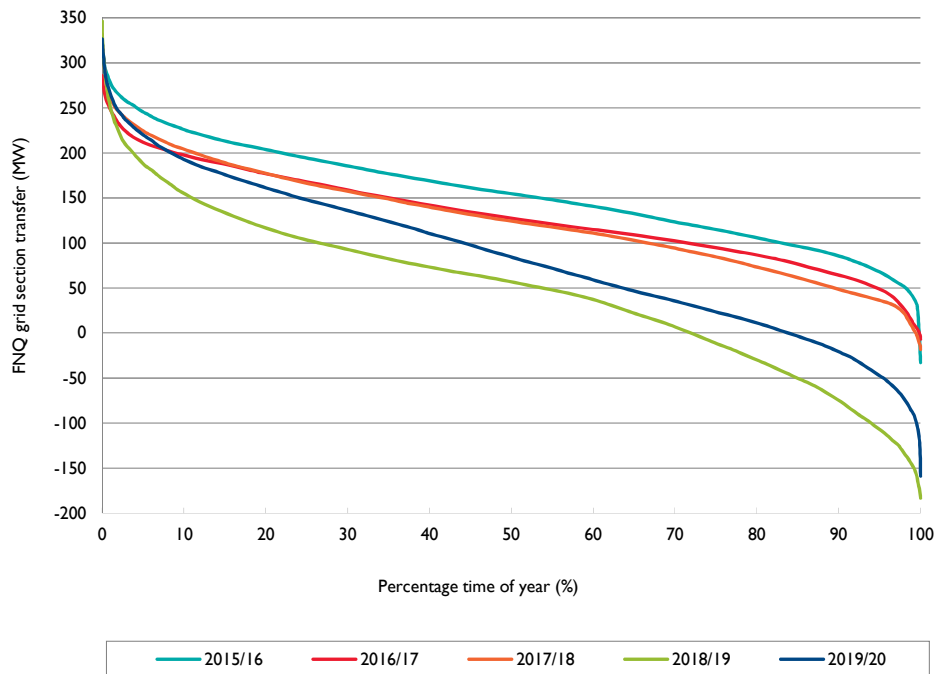

Network augmentations are not planned to occur as a result of network limitations across this grid section within the five-year outlook period.

### 6.6.2 Central Queensland to North Queensland (CQ-NQ) grid section

Maximum power transfer across the CQ-NQ grid section may be set by thermal ratings associated with an outage of a Stanwell to Broadsound 275kV circuit, under certain prevailing ambient conditions. Power transfers may also be constrained by voltage stability limitations associated with the contingency of the Townsville gas turbine or a Stanwell to Broadsound 275kV circuit.

The limit equations in Table D.2 of Appendix D show that the following variables have a significant effect on transfer capability:

- level of Townsville gas turbine generation
- Ross and North zones shunt compensation levels.

The CQ-NQ grid section did not constrain operation during 2019/20. Information pertaining to the historical duration of constrained operation for the CQ-NQ grid section is summarised in Figure 6.11.

# 6 Network capability and performance

Figure 6.11 Historical CQ-NQ grid section constraint times

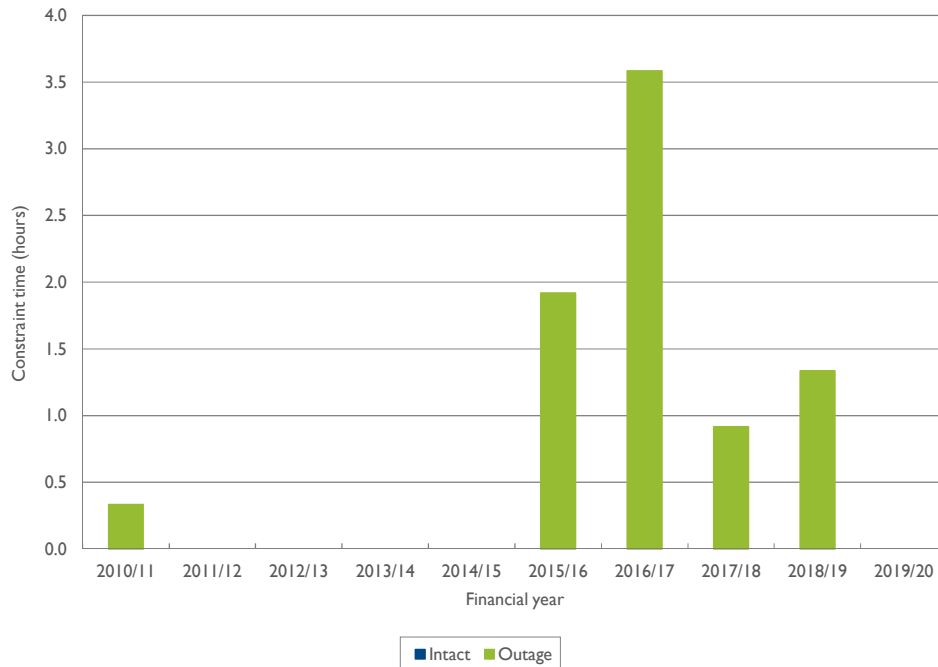

The staged commissioning of double circuit lines from Broadsound to Ross completed in 2010/11 provided increased capacity to this grid section. Since this time constraint times were associated with thermal constraint equations during planned outages to ensure operation within plant thermal ratings. There have been minimal constraints in this grid section since 2010/11.

Figure 6.12 provides historical transfer duration curves showing a large decrease in energy transfer but similar peak transfers over the 2019/20 year. This is predominantly attributed to the recently commissioned Ross River, Sun Metals, Clare, Haughton, Collinsville, Whitsunday, Hamilton, Daydream, Hayman, Rugby Run solar farms and the Mt Emerald Wind Farm. The curves illustrate the ramping with commissioning activities over the last two years. Notably, peak transfers continue to be maintained at similar levels, as high net loading conditions continue to coincide (refer to figures 6.6, 6.7 and 6.8).

Figure 6.12 Historical CQ-NQ grid section transfer duration curves

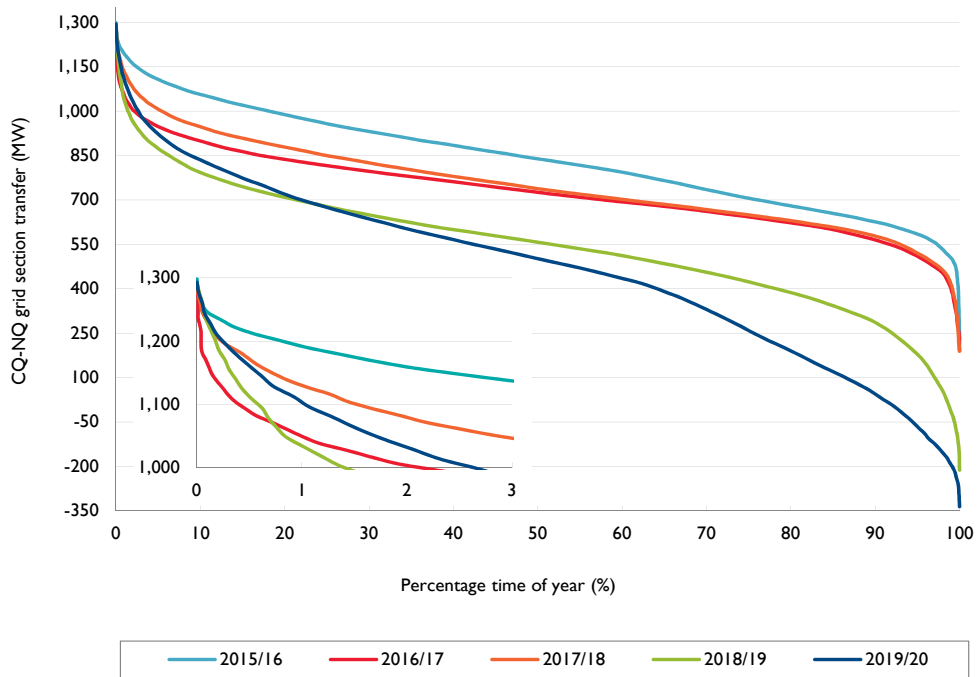
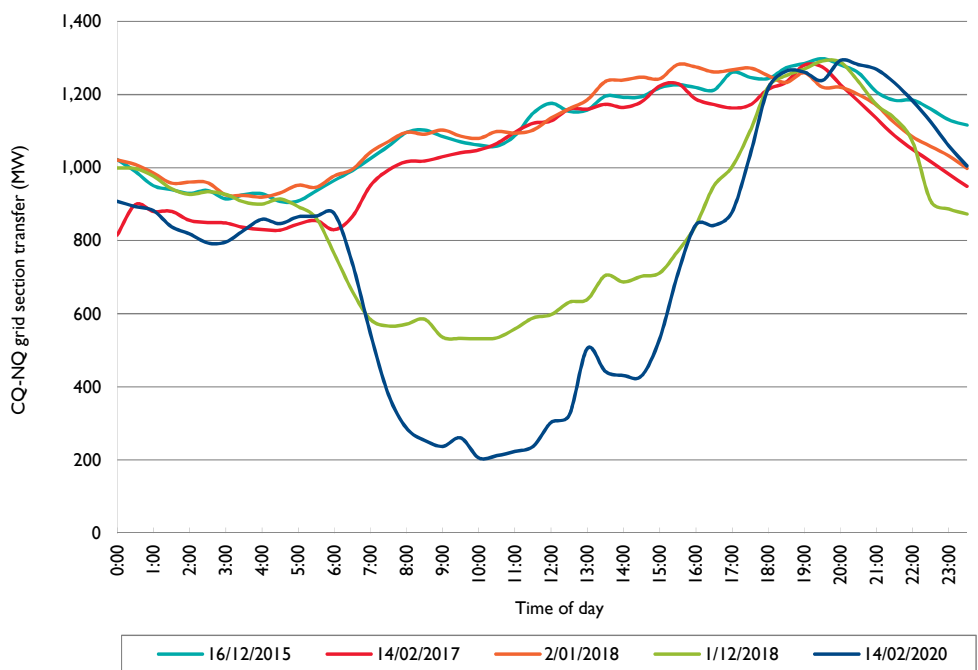

Figure 6.13 provides a different view of the altered power flows experienced over the last year.

Figure 6.13 Historical CQ-NQ peak grid section transfer daily profile



## 6 Network capability and performance

These midday reductions in transfers are introducing operational challenges in voltage control. Midday transfers are forecast to continue reducing with commissioning of additional capacity of VRE generators and integration of additional rooftop photovoltaic (PV) in NQ. Correspondingly, voltage control is forecast to become increasingly challenging for longer durations. Subject to Regulatory Investment Test for Transmission (RIT-T) consultation, Section 5.7.4 proposes the installation of a bus reactor to mitigate the risk of over voltages.

### 6.6.3 NQ System Strength

The Minimum Fault Level rule change that was introduced in 2018 required Powerlink to build a system-wide model to study system strength and its impact on the stability and performance of the power system. Through this work Powerlink understand that the dominant limitation to hosting capacity is the potential for multiple generators, and other transmission-connected dynamic plant, to interact in an unstable manner. These dynamic plant control interactions manifest as an unstable or undamped oscillation in the power system voltage. The frequency of the oscillation is dependent on the participating plants, but is broadly characterised as between 8Hz and 15Hz. The only way to gain an understanding of these oscillations is through detailed, PSCAD system-wide modelling.

In April 2020, AEMO declared a fault level shortfall in NQ at Ross node. As Queensland's TNSP, and therefore System Strength Service Provider, it is Powerlink's responsibility to ensure the minimum fault level is maintained at key nodes as defined by AEMO. In the short-term, Powerlink has achieved this by entering into an interim arrangement with CleanCo Queensland to utilise its assets in FNQ for system strength support. In addition, AEMO has provided preliminary confirmation to Powerlink that, subject to the final exchange of modelling and other details, inverter tuning could reduce the overall system strength requirement at Ross. Consequently Powerlink has entered into an agreement with Daydream, Hamilton, Hayman and Whitsunday Solar Farms in NQ to validate the expected positive benefits of inverter tuning. Powerlink is now working towards a longer-term solution. This is discussed further in sections 5.7.1 and 8.4.

System strength is a measure of the ability of a power system to remain stable under normal conditions and to return to a steady state condition following a system disturbance. System strength can be considered low in areas with low levels of local synchronous generation and deteriorates further with high penetration of inverter-based resources.

The limit equations in Table D.3 of Appendix D show that the following variables currently have a significant effect on NQ system strength:

- number of synchronous units online in Central and NQ
- NQ demand.

Information pertaining to the historical duration of constrained operation for inverter-based resources in NQ is summarised in Figure 6.14. During 2019/20, inverter-based resources in NQ experienced 650 hours of constrained operation, of which 617 hours occurred during intact system conditions. Constrained operation during intact system conditions has occurred for a number of reasons:

- abnormal power system dispatches resulting in fault levels in NQ below minimum fault level requirements<sup>5</sup>
- Powerlink is in the process of addressing a system strength shortfall in NQ that was declared by AEMO in April 2020 (refer to sections 5.7.1 and 8.4.1)
- Two solar farms in NQ have a system strength remediation obligation and until these are in place these plant may be subject to constraints depending on the synchronous dispatch in Central and NQ.

System strength limit equations will be revised as remediation strategies become operational.

---

<sup>5</sup> AEMO, [Notice of Queensland System Strength Requirements and Ross Fault Level Shortfall](#), July 2018.

**Figure 6.14** Historical NQ system strength constraint times

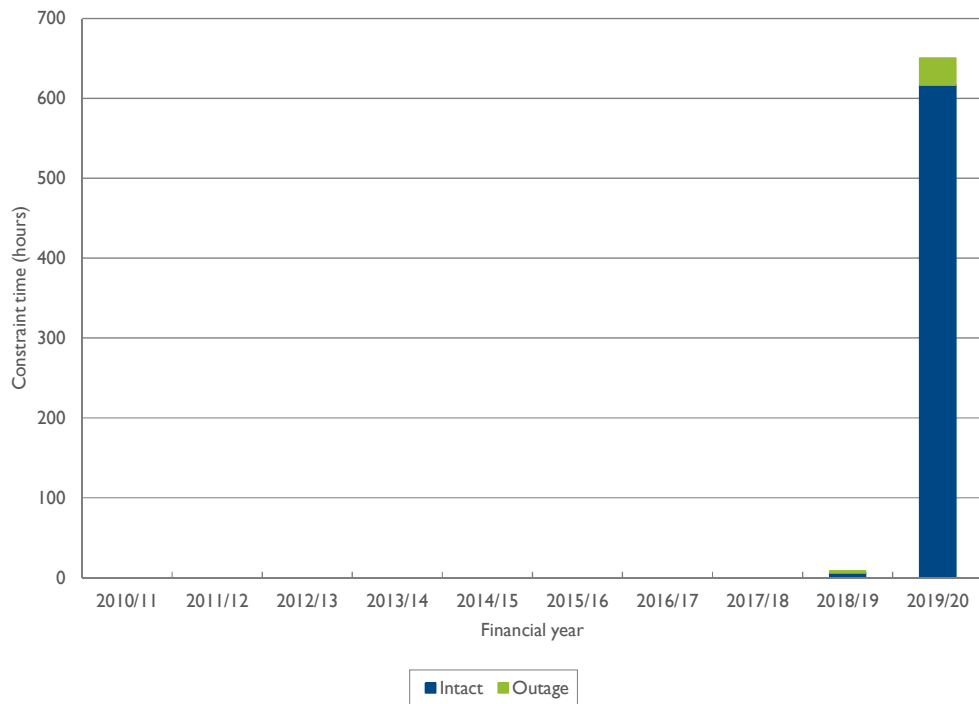

#### 6.6.4 Gladstone grid section

Maximum power transfer across the Gladstone grid section is set by the thermal rating of the Bouldercombe to Raglan, Larcom Creek to Calliope River, Calvale to Wurdong or the Calliope River to Wurdong 275kV circuits.

If the rating would otherwise be exceeded following a critical contingency, generation is constrained to reduce power transfers. Powerlink makes use of dynamic line ratings and rates the relevant circuits to take account of real time prevailing ambient weather conditions to maximise the available capacity of this grid section and, as a result, reduce market impacts. The appropriate ratings are updated in NEMDE.

Information pertaining to the historical duration of constrained operation for the Gladstone grid section is summarised in Figure 6.15. During 2019/20, the Gladstone grid section experienced 16 hours of constrained operation, 15 hours during intact system conditions due to a combination of low Gladstone Power Station generation and high CQ-SQ transfers.



# 6 Network capability and performance

**Figure 6.15** Historical Gladstone grid section constraint times

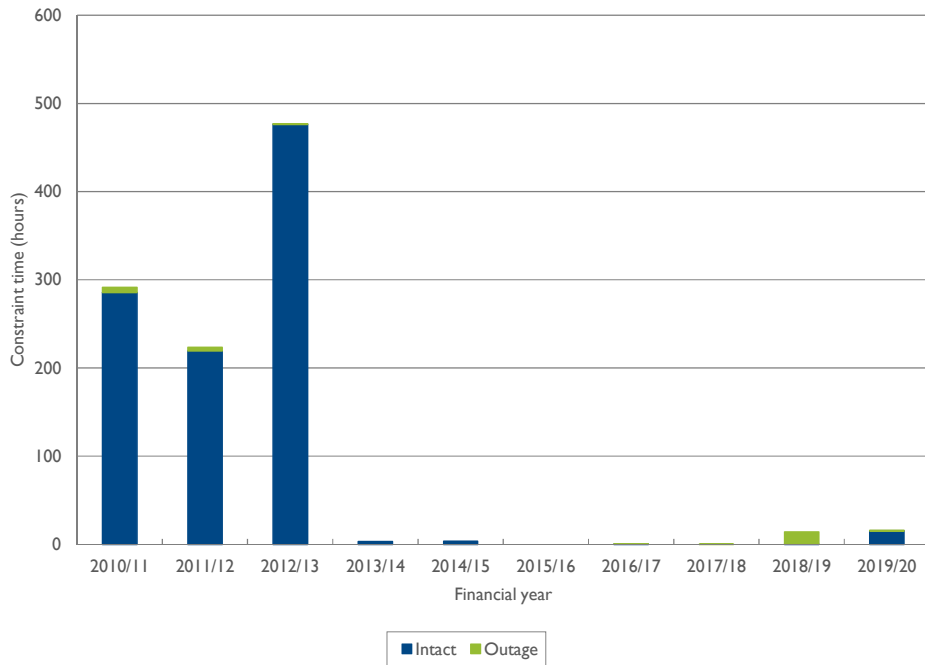

Power flows across this grid section are highly dependent on the dispatch of generation in CQ and transfers to southern Queensland. Figure 6.16 provides historical transfer duration curves showing increased utilisation in 2019/20 compared to 2018/19. Reduced capacity factor from Gladstone Power Station is predominantly responsible for the increase in transfer through this grid section (refer to figures 6.6, 6.7 and 6.8).

**Figure 6.16** Historical Gladstone grid section transfer duration curves

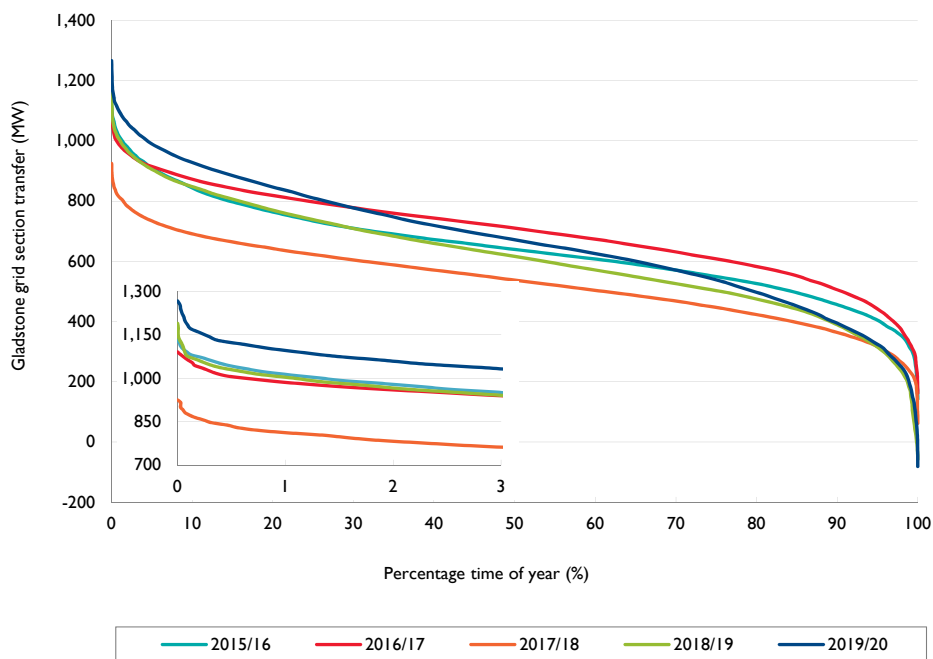

The utilisation of the Gladstone grid section is expected to continue to increase if the recently committed generators displace Gladstone zone or southern generators as this incremental power makes its way to the load in the Gladstone and/or southern Queensland zones.

### 6.6.5 CQ-SQ grid section

Maximum power transfer across the CQ-SQ grid section is set by transient or voltage stability following a Calvale to Halys 275kV circuit contingency.

The voltage stability limit is set by insufficient reactive power reserves in the Central West and Gladstone zones following a contingency. More generating units online in these zones increase reactive power support and therefore transfer capability.

The limit equation in Table D.4 of Appendix D shows that the following variables have significant effect on transfer capability:

- number of generating units online in the Central West and Gladstone zones
- level of Gladstone Power Station generation.

Information pertaining to the historical duration of constrained operation for the CQ-SQ grid section is summarised in Figure 6.17. During 2019/20, the CQ-SQ grid section experienced 593 hours of constrained operation. Constrained operation was mainly associated with planned maintenance outages (this project work is now complete), with only 49 hours constrained in a system normal state.

**Figure 6.17** Historical CQ-SQ grid section constraint times

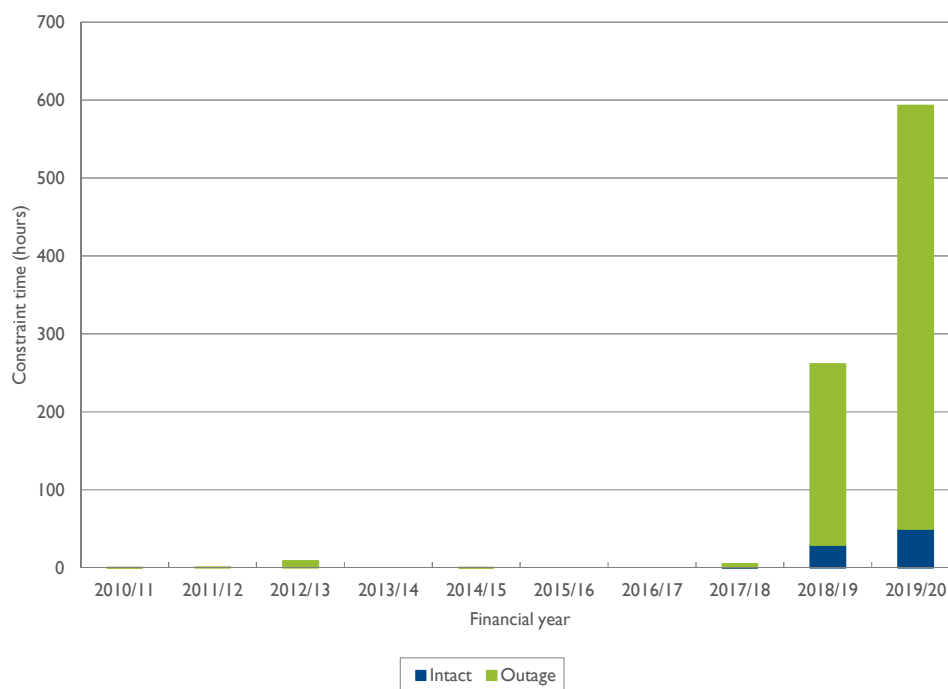
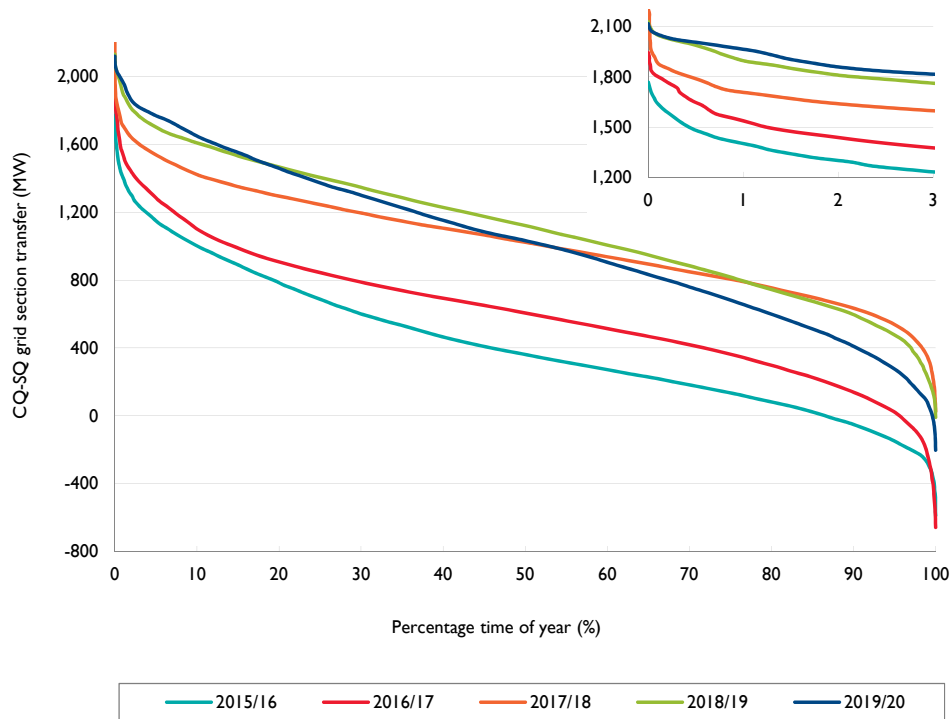

Figure 6.18 provides historical transfer duration curves showing continued increase in utilisation since 2015. This increase in transfer has been predominantly due to a significant reduction in generation from the gas fuelled generators in the Bulli zone and higher interconnector transfers sourced predominantly by generation in central and north Queensland (refer to figures 6.6, 6.7 and 6.8). The utilisation of the CQ-SQ grid section is expected to further increase over time if the newly committed generators in the north displace southern generators.

## 6 Network capability and performance

Figure 6.18 Historical CQ-SQ grid section transfer duration curves



The eastern single circuit transmission lines of CQ-SQ traverse a variety of environmental conditions that have different rates of corrosion resulting in varied risk levels across the transmission lines. Depending on transmission line location, it is expected that sections of lines will be at end of technical service life from the next five to 10 years. This is discussed in Section 5.7.6.

### 6.6.6 Surat grid section

The Surat grid section was introduced in the 2014 TAPR in preparation for the establishment of the Western Downs to Columboola 275kV transmission line<sup>6</sup>, Columboola to Wandoan South 275kV transmission line and Wandoan South and Columboola 275kV substations. These network developments were completed in September 2014 and significantly increased the supply capacity to the Surat Basin north west area.

The maximum power transfer across the Surat grid section is set by voltage stability associated with insufficient reactive power reserves in the Surat zone following an outage of a Western Downs to Orana 275kV circuit. More generating units online in the zone increases reactive power support and therefore transfer capability. Local generation reduces transfer capability but allows more demand to be securely supported in the Surat zone. There have been no constraints recorded over the brief history of the Surat grid section.

Figure 6.19 provides the transfer duration curve since the zone's creation. Grid section transfers depict the ramping of coal seam gas (CSG) load. The zone has transformed from a net exporter to a significant net importer of energy. Energy transfers are expected to reduce with the commitment of Bluegrass, Columboola and Gangarri solar farms.

<sup>6</sup> The Orana Substation is connected to one of the Western Downs to Columboola 275kV transmission lines.

**Figure 6.19** Historical Surat grid section transfer duration curve

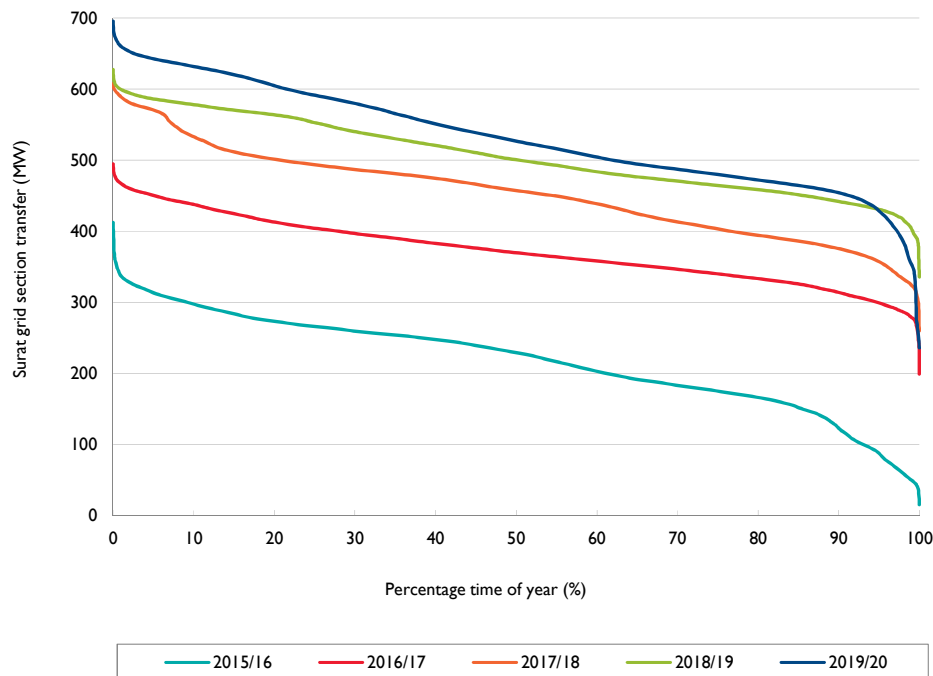

Network augmentations are not planned to occur as a result of network limitations across this grid section within the five-year outlook period.

The development of large loads in Surat (additional to those included in the forecasts), without corresponding increases in generation, can significantly increase the levels of Surat grid section transfers. This is discussed in Section 7.3.5.

### 6.6.7 South West Queensland (SWQ) grid section

The SWQ grid section defines the capability of the transmission network to transfer power from generating stations located in the Bulli zone and northerly flow on QNI to the rest of Queensland. The grid section is not expected to impose limitations to power transfer under intact system conditions with existing levels of generating capacity.

The SWQ grid section did not constrain operation during 2019/20. Information pertaining to the historical duration of constrained operation for the SWQ grid section is summarised in Figure 6.20.

# 6 Network capability and performance

**Figure 6.20** Historical SWQ grid section constraint times

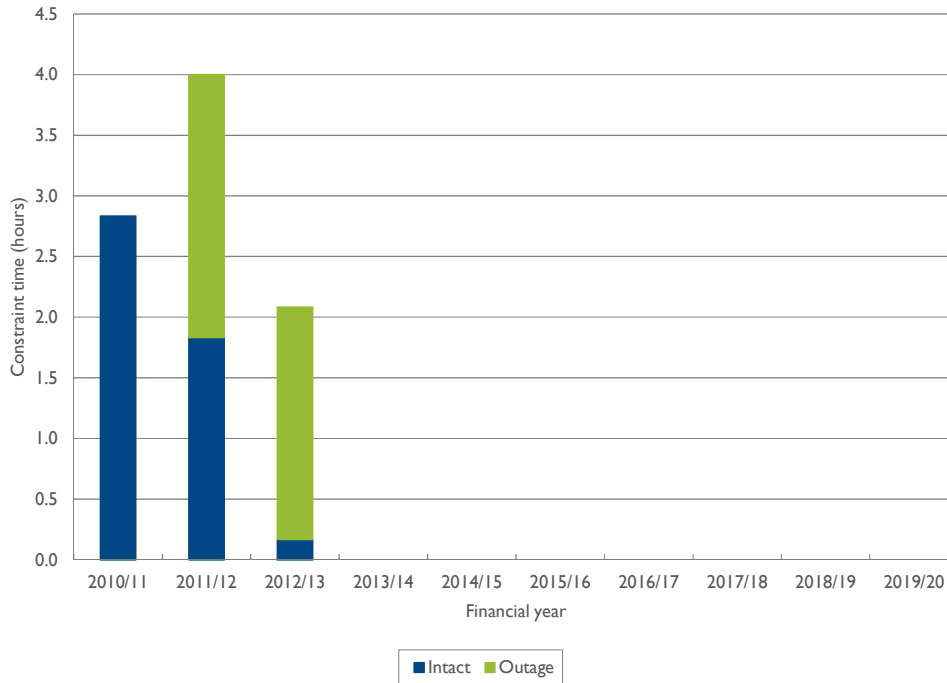
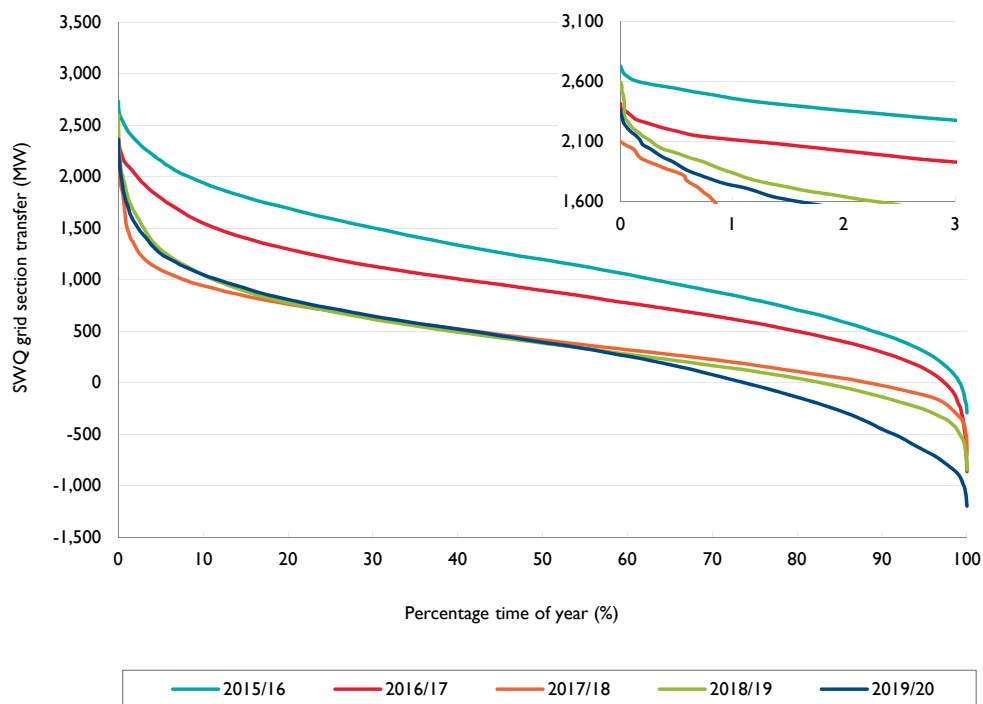

Figure 6.21 provides historical transfer duration curves showing reductions in energy transfer since 2015/16. Reductions in South West, Wide Bay, Moreton and Gold Coast delivered demands (refer to figures 6.6, 6.7 and 6.8) are predominantly responsible for the reduction in SWQ utilisation.

**Figure 6.21** Historical SWQ grid section transfer duration curves



Network augmentations are not planned to occur as a result of network limitations across this grid section within the five-year outlook period.

### 6.6.8 Tarong grid section

Maximum power transfer across the Tarong grid section is set by voltage stability associated with the loss of a Calvale to Halys 275kV circuit. The limitation arises from insufficient reactive power reserves in southern Queensland.

Limit equations in Table D.5 of Appendix D show that the following variables have a significant effect on transfer capability:

- QNI transfer and South West and Bulli zones generation
- level of Moreton zone generation
- Moreton and Gold Coast zones capacitive compensation levels.

Any increase in generation west of this grid section, with a corresponding reduction in generation north of the grid section, reduces the CQ-SQ power flow and increases the Tarong limit. Increasing generation east of the grid section reduces the transfer capability, but increases the overall amount of supportable South East Queensland (SEQ) demand. This is because reactive margins increase with additional local generation, allowing further load to be delivered before reaching minimum allowable reactive margins. However, due to its distributed and reactive nature, increases in delivered demand erode reactive margins at greater rates than they were created by the additional local generation. Limiting power transfers are thereby lower with the increased local generation but a greater load can be delivered.

Information pertaining to the historical duration of constrained operation for the Tarong grid section is summarised in Figure 6.22. During 2019/20, the Tarong grid section appears to have been constrained for two hours and one hour during 2018/19. Powerlink is working with AEMO to investigate the reason for this congestion.

**Figure 6.22** Historical Tarong grid section constraint times

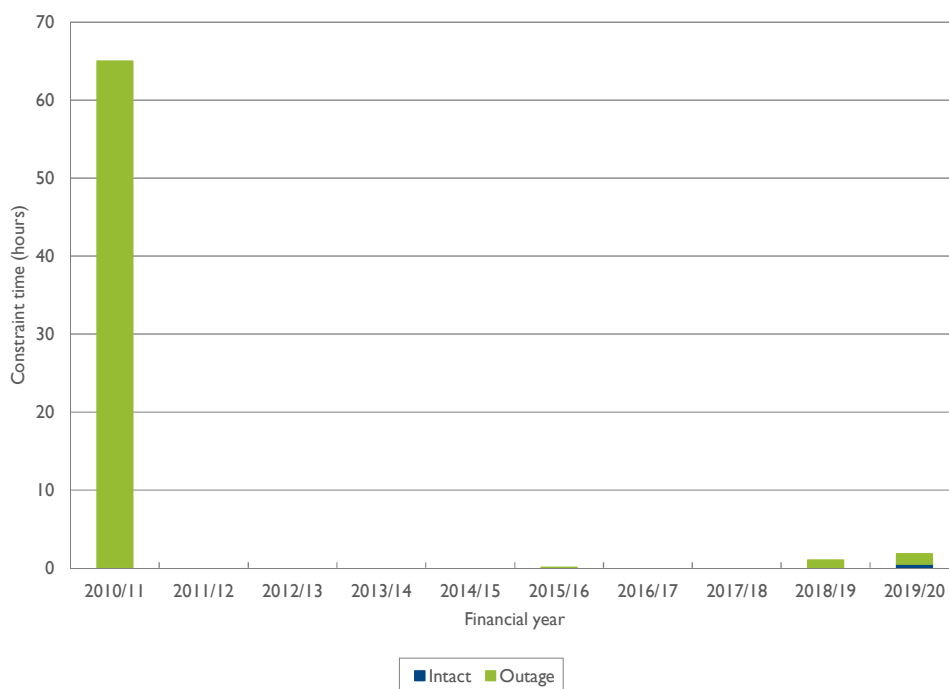

## 6 Network capability and performance

Constraint times have been minimal over the last 10 years, with the exception of 2010/11, where constraint times are associated with line outages as a result of severe weather events in January 2011.

Figure 6.23 provides historical transfer duration curves showing small annual differences in grid section transfer demands. The reduction in transfer between 2016/17 and 2017/18 is predominantly attributed to the return to service of Swanbank E from its mothballed state. The 2019/20 trace reflects lower energy transfers into SEQ as a result of Wivenhoe and Swanbank E generation and lower Wide Bay, Moreton and Gold Coast delivered demands (refer to figures 6.6, 6.7 and 6.8).

**Figure 6.23** Historical Tarong grid section transfer duration curves

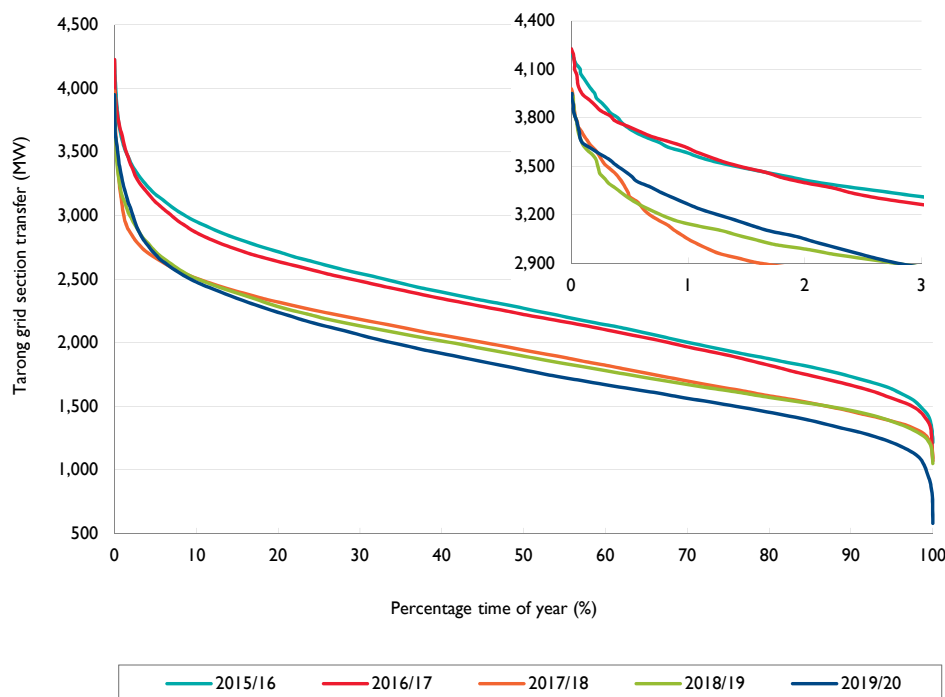

Network augmentations are not planned to occur as a result of network limitations across this grid section within the five year outlook period.

### 6.6.9 Gold Coast grid section

Maximum power transfer across the Gold Coast grid section is set by voltage stability associated with the loss of a Greenbank to Molendinar 275kV circuit, or Greenbank to Mudgeeraba 275kV circuit.

The limit equation in Table D.6 of Appendix D shows that the following variables have a significant effect on transfer capability:

- number of generating units online in Moreton zone
- level of Terranora Interconnector transmission line transfer
- Moreton and Gold Coast zones capacitive compensation levels
- Moreton zone to the Gold Coast zone demand ratio.

Reducing southerly flow on Terranora Interconnector reduces transfer capability, but increases the overall amount of supportable Gold Coast demand. This is because reactive margins increase with reductions in southerly Terranora Interconnector flow, allowing further load to be delivered before reaching minimum allowable reactive margins. However, due to its distributed and reactive nature, increases in delivered demand erode reactive margins at greater rates than they were created by the reduction in Terranora Interconnector southerly transfer. Limiting power transfers are thereby lower with reduced Terranora Interconnector southerly transfer but a greater load can be delivered.

The Gold Coast grid section did not constrain operation during 2019/20. Information pertaining to the historical duration of constrained operation for the Gold Coast grid section is summarised in Figure 6.24.

**Figure 6.24** Historical Gold Coast grid section constraint times

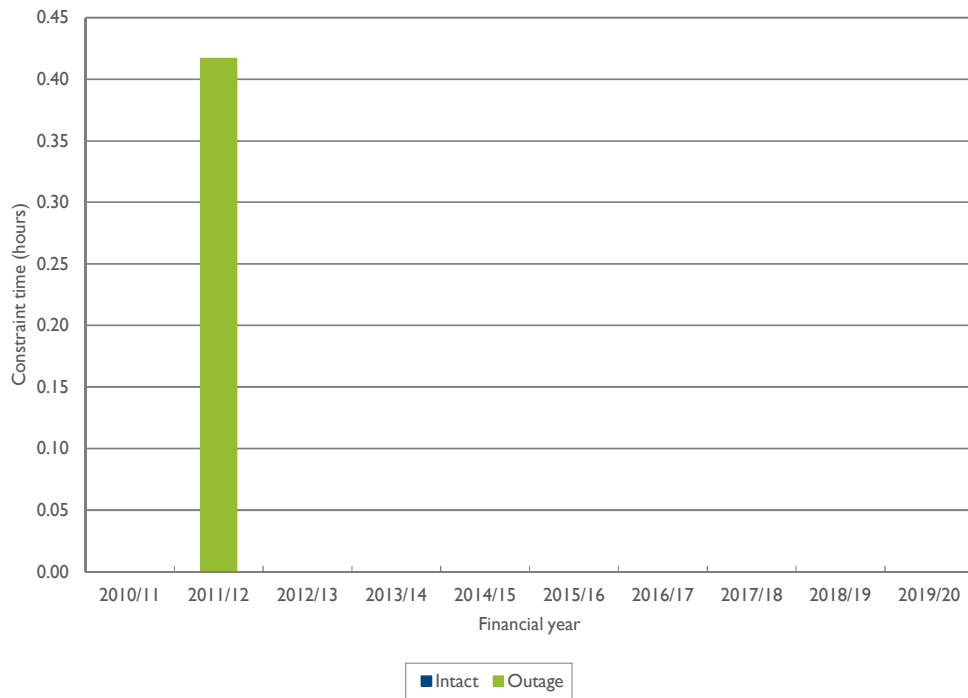

Constraint times have been minimal since 2007, with the exception of 2010/11 where constraint times are associated with the planned outage of one of the 275kV Greenbank to Mudgeeraba feeders.

Figure 6.25 provides historical transfer duration curves showing changes in grid section transfer demands and energy in line with changes in transfer to northern NSW and changes in Gold Coast loads. Northern NSW transfers and Gold Coast zone demand were lower in 2019/20 compared to 2018/19 (refer to Section 6.7.11).



## 6 Network capability and performance

Figure 6.25 Historical Gold Coast grid section transfer duration curves

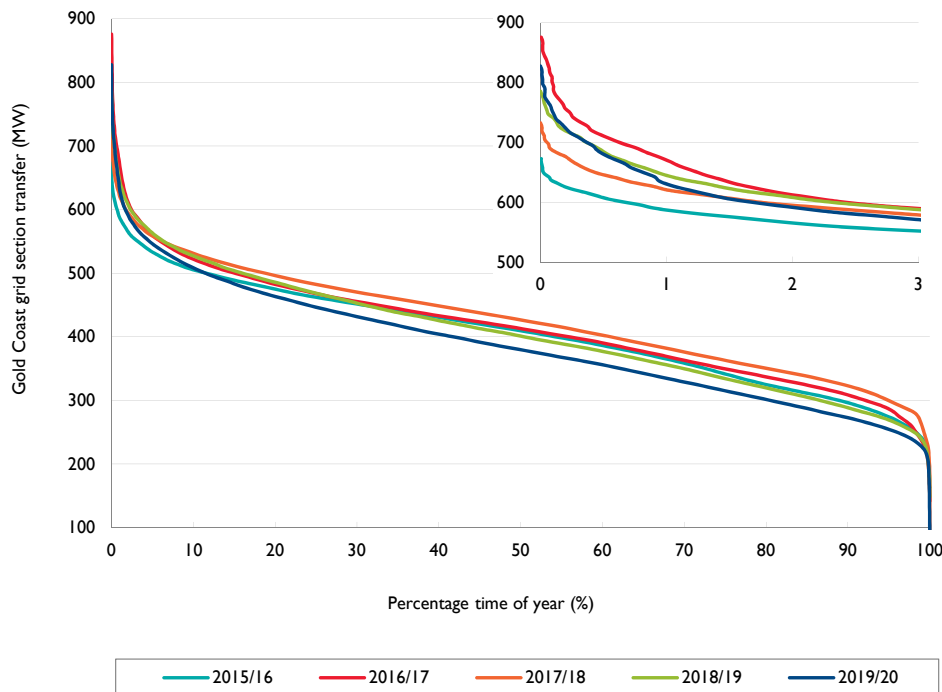

Due to condition drivers, Powerlink is proposing to retire one of the aging 275/110kV transformers at Mudgeeraba Substation by 2020. This is discussed further in Section 5.7.11.

### 6.6.10 QNI and Terranora Interconnector

The transfer capability across QNI is limited by voltage stability, transient stability, oscillatory stability, and line thermal rating considerations. The capability across QNI at any particular time is dependent on a number of factors, including demand levels, generation dispatch, status and availability of transmission equipment, and operating conditions of the network.

AEMO publish Monthly Constraint Reports which includes a section examining each of the NEM interconnectors, including QNI and Terranora Interconnector. Information pertaining to the historical duration of constrained operation for QNI and Terranora Interconnector is contained in these Monthly Constraint Reports. The Monthly Constraint Report can be found on AEMO's website.

For intact system operation, the southerly transfer capability of QNI is most likely to be set by the following:

- voltage stability associated with a fault on the Sapphire to Armidale 330kV transmission line in NSW
- transient stability associated with transmission faults near the Queensland border
- transient stability associated with the trip of a smelter potline load in Queensland
- transient stability associated with transmission faults in the Hunter Valley in NSW
- transient stability associated with a fault on the Hazelwood to South Morang 500kV transmission line in Victoria
- thermal capacity of the 330kV transmission network between Armidale and Liddell in NSW
- oscillatory stability upper limit of 1,200MW.

For intact system operation, the combined northerly transfer capability of QNI and Terranora Interconnector is most likely to be set by the following:

- transient and voltage stability associated with transmission line faults in NSW

- transient stability and voltage stability associated with loss of the largest generating unit in Queensland
- thermal capacity of the 330kV and 132kV transmission network within northern NSW
- oscillatory stability upper limit of 700MW.

In December 2019, Powerlink and TransGrid released a Project Assessment Conclusion Report (PACR) on 'Expanding NSW-Queensland transmission transfer capacity', identifying the preferred option which includes upgrading the 330kV Liddell to Tamworth 330kV lines, and installing Static VAR Compensators (SVC) at Tamworth and Dumaresq substations and static capacitor banks at Tamworth, Armidale and Dumaresq substations. The project is expected to be completed by June 2022 at a cost of \$217 million.

AEMO's Integrated System Plan (ISP) continues to investigate opportunities for expansion of interconnector capacity. In the 2020 ISP AEMO identified QNI Medium and Large projects as future ISP projects, requiring Powerlink and TransGrid to undertake preparatory activities by 30 June 2021.

## 6.7 Zone performance

This section presents, where applicable, a summary of:

- the capability of the transmission network to deliver loads
- historical zonal transmission delivered loads
- intra-zonal system normal constraints
- double circuit transmission lines categorised as vulnerable by AEMO
- Powerlink's management of high voltages associated with light load conditions.

Double circuit transmission lines that experience a lightning trip of all phases of both circuits are categorised by AEMO as vulnerable. A double circuit transmission line in the vulnerable list is eligible to be reclassified as a credible contingency event during a lightning storm if a cloud to ground lightning strike is detected close to the line. A double circuit transmission line will remain on the vulnerable list until it is demonstrated that the asset characteristics have been improved to make the likelihood of a double circuit lightning trip no longer reasonably likely to occur or until the Lightning Trip Time Window (LTTW) expires from the last double circuit lightning trip. The LTTW is three years for a single double circuit trip event or five years where multiple double circuit trip events have occurred during the LTTW.

Zonal transmission delivered energy, in general, has remained steady in 2019/20, compared to 2018/19 (refer to Figure 6.8), despite reductions in the last quarter of the financial year due to COVID-19 pandemic impacts, significant increases in embedded VRE generation and Queensland's installed rooftop PV reaching 3,285MW in June 2020.

### 6.7.1 Far North zone

The Far North zone experienced no load loss for a single network element outage during 2019/20.

The Far North zone includes the non-scheduled embedded generator Lakeland Solar and Storage as defined in Figure 2.6. This embedded generator provided approximately 20GWh during 2019/20.

Figure 6.26 provides historical transmission delivered load duration curves for the Far North zone. Energy delivered from the transmission network has reduced by 3.3% between 2018/19 and 2019/20. The maximum transmission delivered demand in the zone was 364MW, which is below the highest maximum demand over the last five years of 381MW set in 2018/19. The minimum transmission delivered demand in the zone was 88MW, which is the lowest minimum demand over the last five years.

# 6 Network capability and performance

Figure 6.26 Historical Far North zone transmission delivered load duration curves

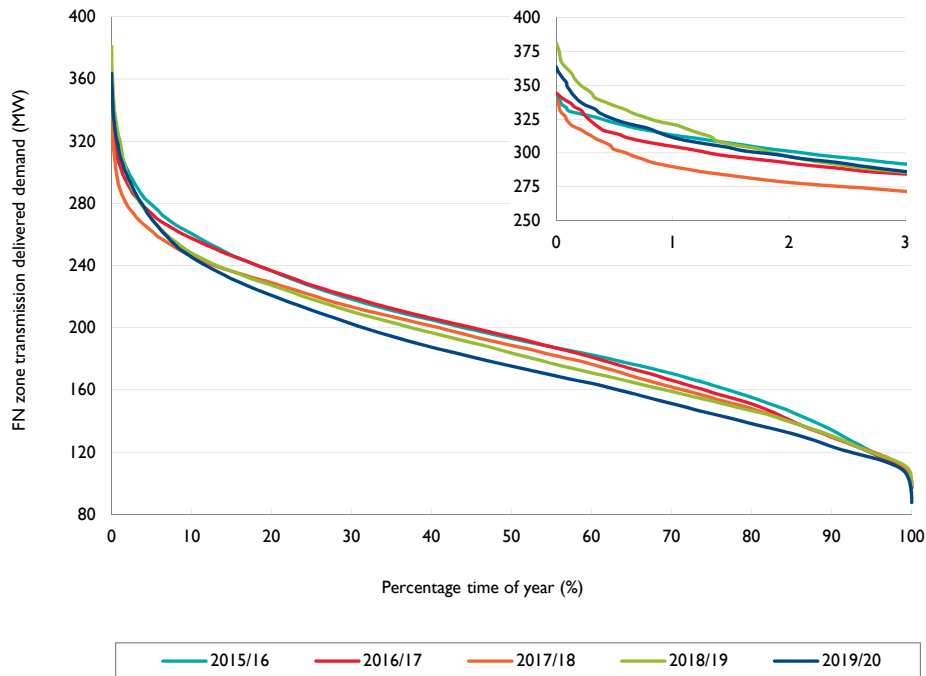

High voltages associated with these light load conditions are currently managed with existing reactive sources. However, voltage control within Powerlink's and Ergon Energy's network is forecast to become increasingly challenging for longer durations.

As a result of double circuit outages associated with lightning strikes, AEMO has included Chalumbin to Turkinje 132kV in the vulnerable list. This double circuit tripped due to lightning in January 2016.

## 6.7.2 Ross zone

The Ross zone experienced no load loss for a single network element outage during 2019/20.

The Ross zone includes the scheduled embedded Townsville Power Station 66kV component, semi-scheduled distribution connected embedded Kidston Solar Farm, Kennedy Energy Park and direct connected embedded Sun Metals Solar Farm, and the significant non-scheduled embedded generators Hughenden Solar Farm and Pioneer Mill as defined in Figure 2.6. These embedded generators provided approximately 434GWh during 2019/20.

Figure 6.27 provides historical transmission delivered load duration curves for the Ross zone. Energy delivered from the transmission network has increased by 5.4% between 2018/19 and 2019/20.

The increase in energy delivered is predominantly due to the reduction in energy from embedded generation. The peak transmission delivered demand in the zone was 518MW which is below the highest maximum demand over the last five years of 574MW set in 2016/17. The minimum transmission delivered demand in the zone was 39MW, which is above the lowest demand over the last five years of 36MW set in 2018/19.

**Figure 6.27** Historical Ross zone transmission delivered load duration curves

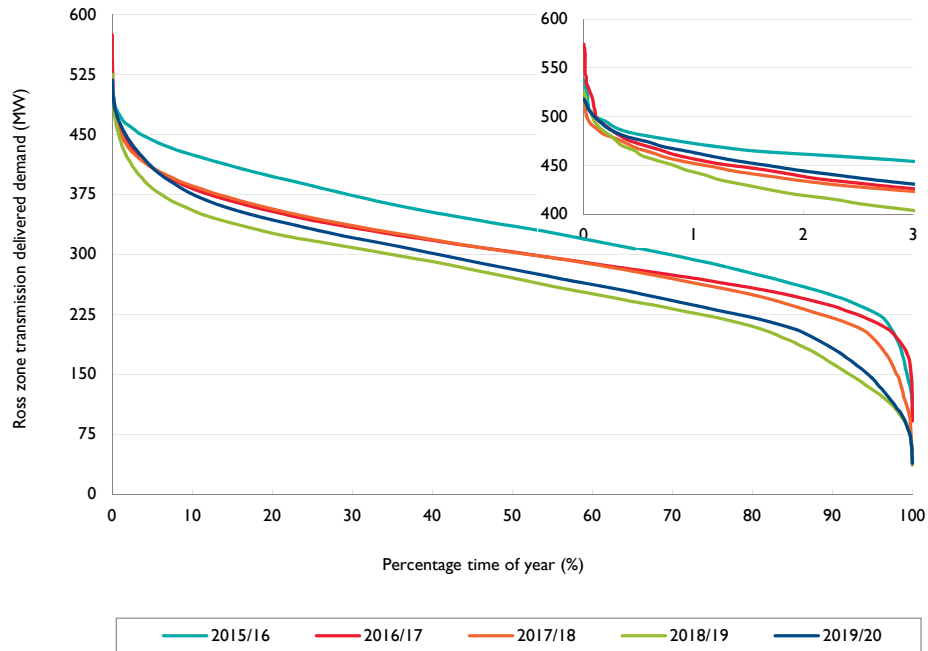

As a result of double circuit outages associated with lightning strikes, AEMO has included the Ross to Chalumbin 275kV double circuit transmission line in the vulnerable list. This double circuit tripped due to lightning in January 2020.

High voltages associated with light load conditions are managed with existing reactive sources.

### 6.7.3 North zone

The North zone experienced no load loss for a single network element outage during 2019/20.

The North zone includes the scheduled embedded Mackay generator, semi-scheduled embedded generator Collinsville Solar Farm and significant non-scheduled embedded generators Moranbah North, Moranbah and Racecourse Mill as defined in Figure 2.6. These embedded generators provided approximately 665GWh during 2019/20.

Figure 6.28 provides historical transmission delivered load duration curves for the North zone. Energy delivered from the transmission network has reduced by 4.9% between 2018/19 and 2019/20. The peak transmission delivered demand in the zone was 464MW, which is below the highest maximum demand over the last five years of 488MW set in 2015/16. The minimum transmission delivered demand in the zone was 143MW, which is above the lowest demand over the last five years of 32MW set in 2016/17 as a result of lost load following Ex-Tropical Cyclone Debbie.

# 6 Network capability and performance

Figure 6.28 Historical North zone transmission delivered load duration curves

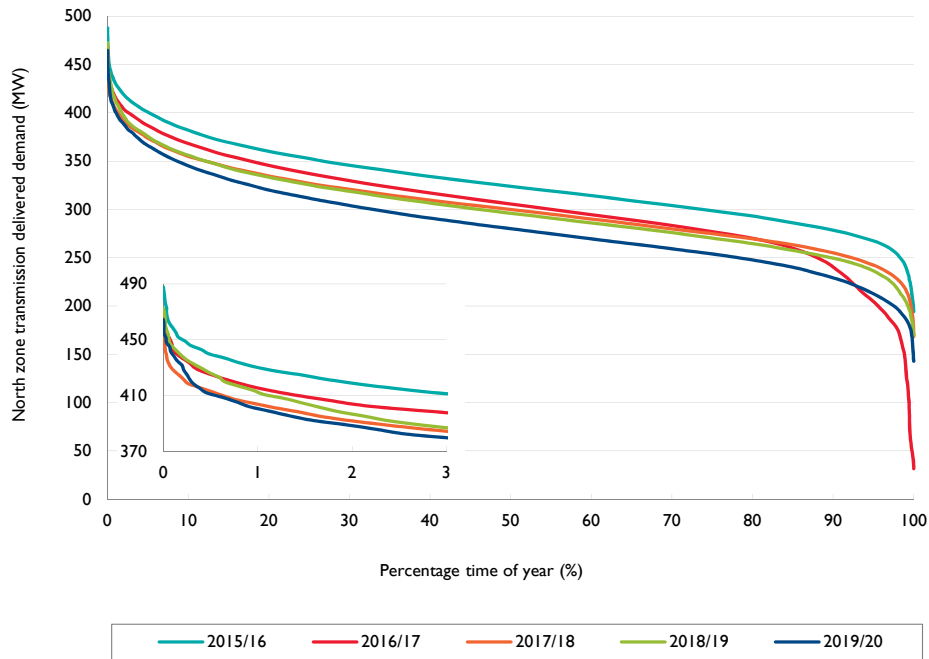

As a result of double circuit outages associated with lightning strikes, AEMO includes the following double circuits in the North zone in the vulnerable list:

- Strathmore to Clare South and Collinsville North to King Creek to Clare South 132kV double circuit transmission line, last tripped January 2019
- Collinsville North to Proserpine 132kV double circuit transmission line, last tripped February 2018
- Collinsville North to Stony Creek and Collinsville North to Newlands 132kV double circuit transmission line, last tripped February 2016
- Goonyella to North Goonyella and Goonyella to Newlands 132kV double circuit transmission line, last tripped February 2018
- Moranbah to Goonyella Riverside 132kV double circuit transmission line, last tripped December 2014.

High voltages associated with light load conditions are currently managed with existing reactive sources. However, midday power transfer levels continue to reduce as capacity is released from commissioning activities of VRE generators and additional rooftop PV is installed in NQ. As a result, voltage control is forecast to become increasingly challenging for longer durations. This is discussed in sections 6.6.2 and 5.7.4.

## 6.7.4 Central West zone

The Central West zone experienced no load loss for a single network element outage during 2019/20.

The Central West zone includes the scheduled embedded Barcaldine generator, semi-scheduled embedded generators Clermont Solar Farm and Emerald Solar Farm and significant non-scheduled embedded generators Barcaldine Solar Farm, Longreach Solar Farm, German Creek and Oaky Creek as defined in Figure 2.6. These embedded generators provided approximately 797GWh during 2019/20.

Figure 6.29 provides historical transmission delivered load duration curves for the Central West zone. Energy delivered from the transmission network has reduced by 4.6% between 2018/19 and 2019/20. The reduction in energy delivered is due to the increase in energy from embedded generation. The peak transmission delivered demand in the zone was 555MW, which is the highest maximum demand over the last five years. The minimum transmission delivered demand in the zone was 83MW, which is the lowest demand on record.

Figure 6.29 Historical Central West zone transmission delivered load duration curves

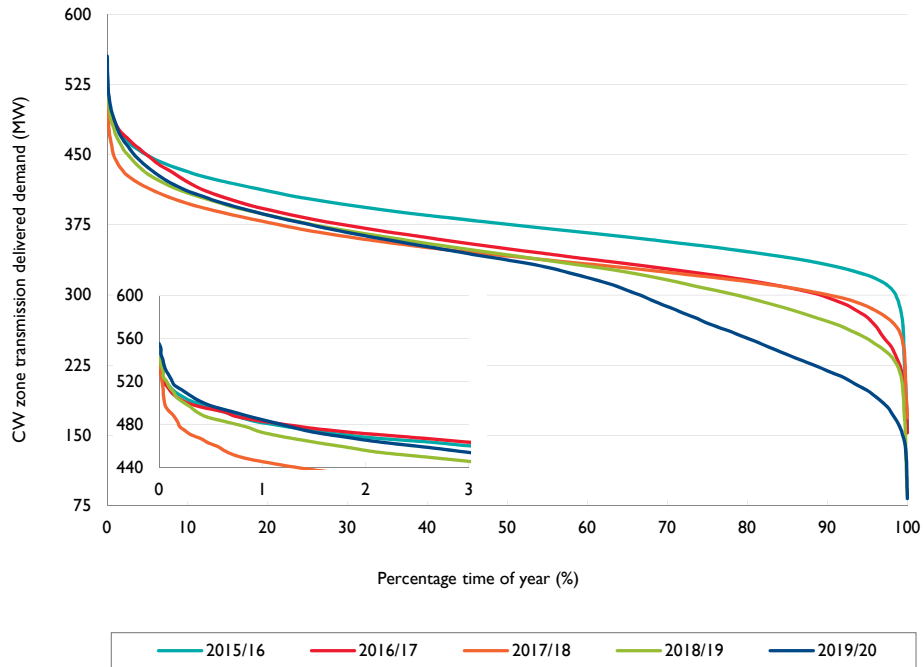

### 6.7.5 Gladstone zone

The Gladstone zone experienced no load loss for a single network element outage during 2019/20.

The Gladstone zone contains no scheduled, semi-scheduled or significant non-scheduled embedded generators as defined in Figure 2.6.

Figure 6.30 provides historical transmission delivered load duration curves for the Gladstone zone. The Figure clearly shows a reduction in demand between 2015/16 and 2016/17 due to changed operation by Boyne Smelters Limited (BSL). Energy delivered from the transmission network has reduced by 0.5% between 2018/19 and 2019/20. The peak transmission delivered demand in the zone was 1,125MW, which is below the highest maximum demand over the last five years of 1,274MW set in 2015/16. Minimum demand coincides with small periods when one or more smelter potlines are out of service. The minimum transmission delivered demand in the zone was 638MW, which is above the lowest demand over the last five years of 418MW set in 2016/17.

## 6 Network capability and performance

Figure 6.30 Historical Gladstone zone transmission delivered load duration curves

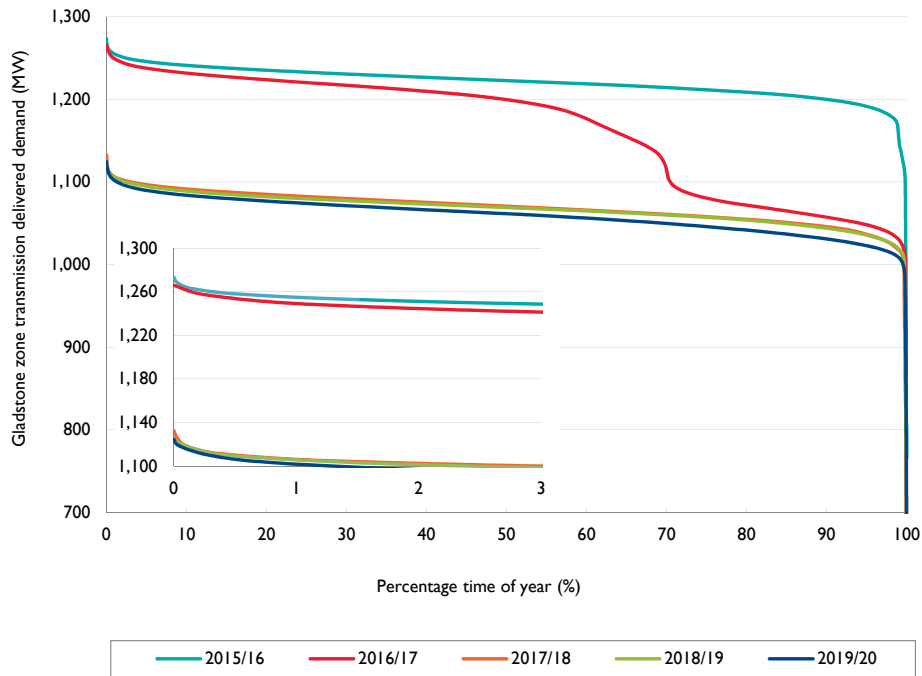

Constraints occur within the Gladstone zone under intact network conditions. These constraints are associated with maintaining power flows within the continuous current rating of a 132kV feeder bushing within BSL's substation. The constraint limits generation from Gladstone Power Station, mainly from the units connected at 132kV. AEMO identifies this constraint by constraint identifier Q>NIL\_BI\_FB. This constraint was implemented in AEMO's market system from September 2011.

Information pertaining to the historical duration of constrained operation due to this constraint is summarised in Figure 6.31. During 2019/20, the feeder bushing constraint experienced 264 hours of constrained operation, 163 hours during outage of 275kV feeders between Calliope River and Woolooga.

Figure 6.31 Historical Q>NIL\_BI\_FB constraint times

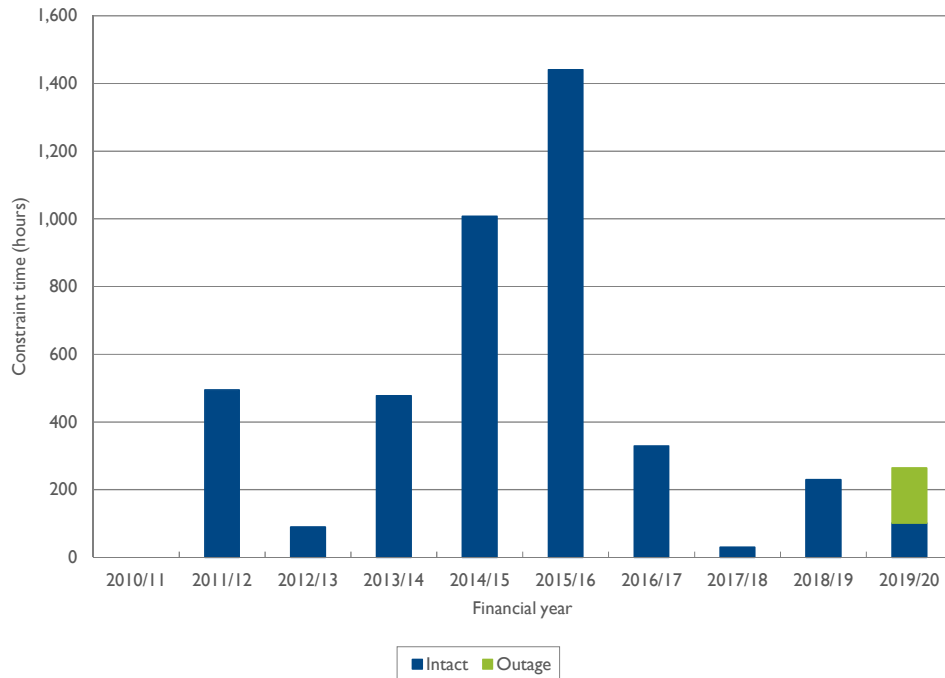

### 6.7.6 Wide Bay zone

The Wide Bay zone experienced no load loss for a single network element outage during 2019/20.

The Wide Bay zone includes the semi-scheduled embedded generators Childers Solar Farm and Susan River Solar Farm, and significant non-scheduled embedded generator Isis Central Sugar Mill as defined in Figure 2.6. These embedded generators provided approximately 251GWh during 2019/20.

Figure 6.32 provides historical transmission delivered load duration curves for the Wide Bay zone. Wide Bay zone is one of two zones in Queensland where the delivered demand reaches negative values, meaning that the embedded generation exceeds the native load, the transmission network supplying the zone is often operated at zero and near zero loading, and the embedded generation makes use of the transmission network to feed loads in other zones. Figure 6.33 provides the daily load profile for the minimum transmission delivered days over the last five years.

Whilst energy has seen significant reductions, the peak demand, which occurs at night, remains at similar levels. Energy delivered from the transmission network reduced by 14.0% between 2018/19 and 2019/20. The reduction in energy delivered is due to the increase in energy from embedded generation. The peak transmission delivered demand in the zone was 295MW, which is below the highest maximum demand over the last five years of 301MW set in 2017/18. The minimum transmission delivered demand in the zone was -82MW, which is the lowest demand on record.



# 6 Network capability and performance

Figure 6.32 Historical Wide Bay zone transmission delivered load duration curves

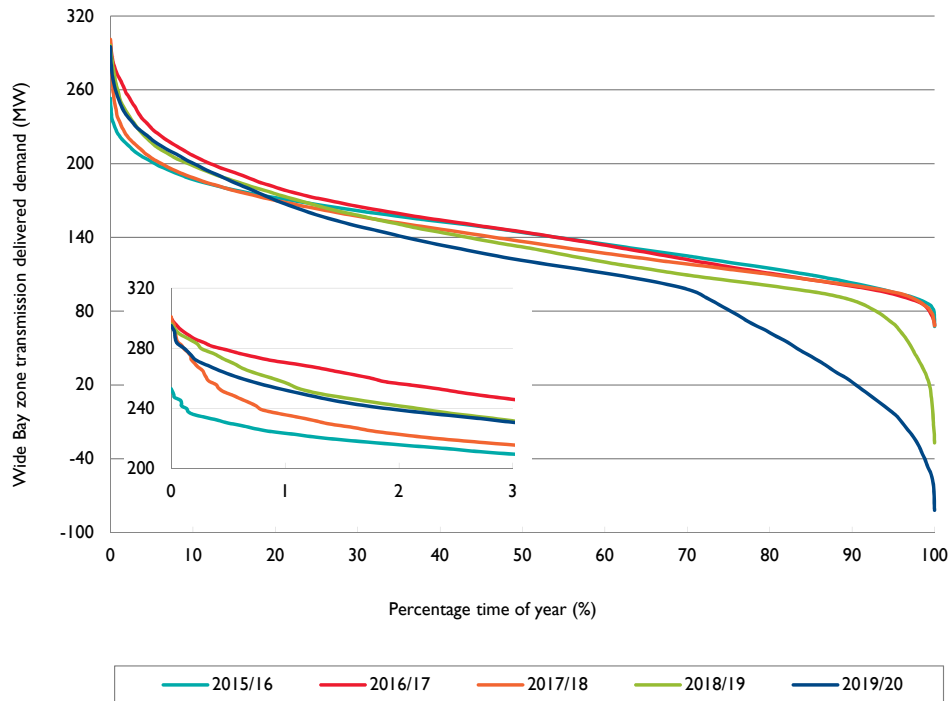
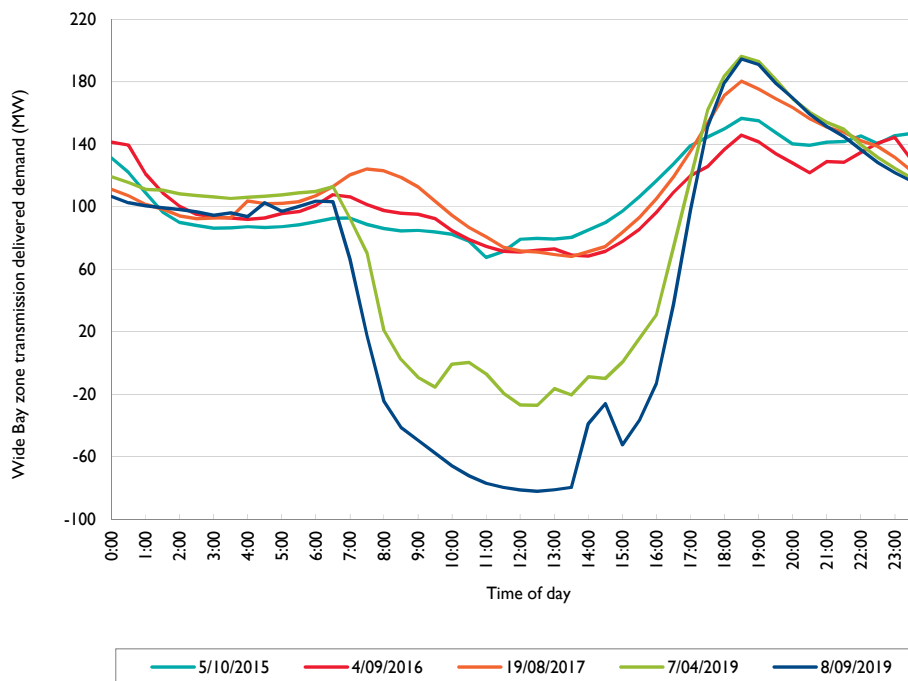

Figure 6.33 Historical Wide Bay zone minimum transmission delivered daily profile



### 6.7.7 Surat zone

The Surat zone experienced no load loss for a single network element outage during 2019/20.

The Surat zone includes the scheduled embedded Roma and Condamine generators and significant non-scheduled embedded generator Baking Board Solar Farm as defined in Figure 2.6. These embedded generators provided approximately 371GWh during 2019/20.

Figure 6.34 provides historical transmission delivered load duration curves for the Surat zone. Energy delivered from the transmission network has increased by approximately 4.6% between 2018/19 and 2019/20. The peak transmission delivered demand in the zone was 690MW, which is the highest maximum demand over the last five years. The CSG load in the zone has now reached expected demand levels. The minimum transmission delivered demand in the zone was 328MW, which is above the lowest demand over the last five years of 106MW set in 2015/16.

**Figure 6.34** Historical Surat zone transmission delivered load duration curves

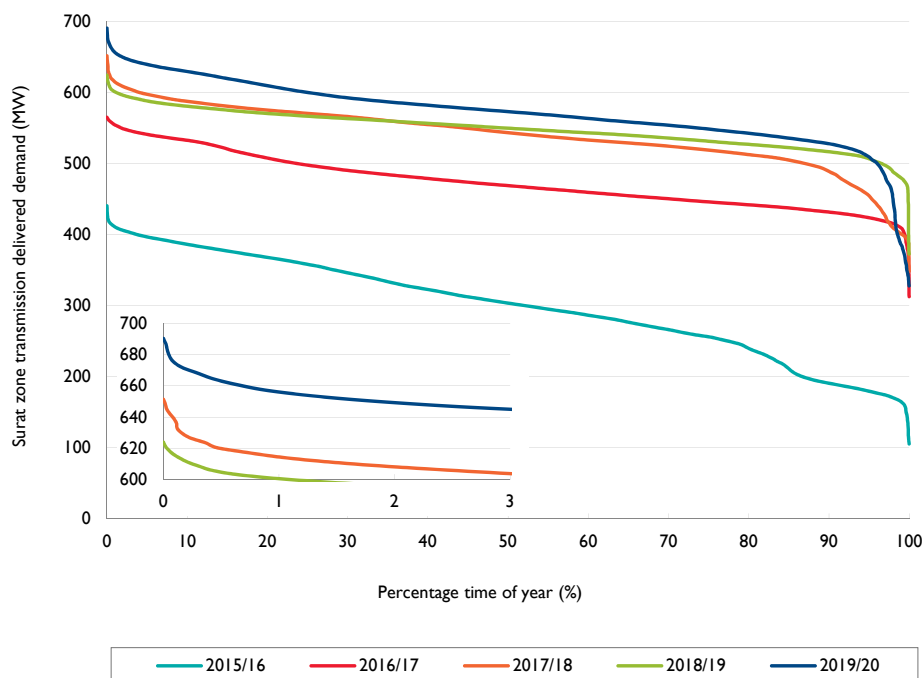

As a result of double circuit outages associated with lightning strikes, AEMO includes the Tarong to Chinchilla 132kV double circuit transmission line in the vulnerable list. This double circuit tripped due to lightning in February 2018.

### 6.7.8 Bulli zone

The Bulli zone experienced no load loss for a single network element outage during 2019/20.

The Bulli zone contains no scheduled, semi-scheduled or significant non-scheduled embedded generators as defined in Figure 2.6.

Figure 6.35 provides historical transmission delivered load duration curves for the Bulli zone. Energy delivered from the transmission network has increased by approximately 4.0% between 2018/19 and 2019/20. The peak transmission delivered demand in the zone was 210MW, which is the highest maximum demand. The CSG load in the zone has now reached expected demand levels. The minimum transmission delivered demand in the zone was 73MW, which is above the lowest demand over the last five years of 56MW set in 2017/18.

# 6 Network capability and performance

Figure 6.35 Historical Bulli zone transmission delivered load duration curves

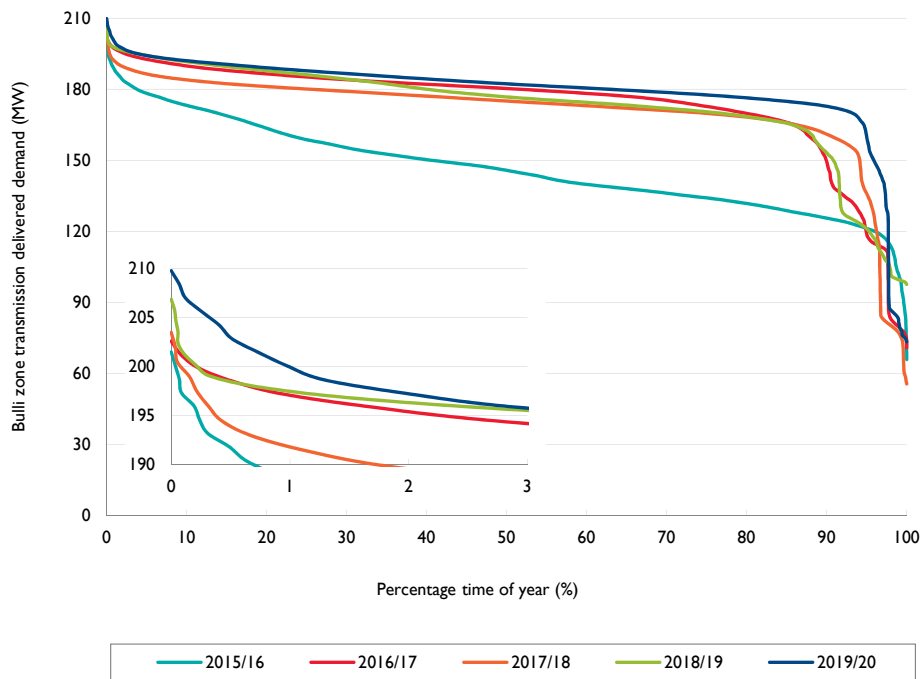

## 6.7.9 South West zone

The South West zone experienced no load loss for a single network element outage during 2019/20.

The South West zone includes the semi-scheduled embedded generators Oakey 1 Solar Farm, Oakey 2 Solar Farm, Yarranlea Solar Farm, Maryrorough Solar Farm and significant non-scheduled embedded generator Daandine Power Station as defined in Figure 2.6. These embedded generators provided approximately 338GWh during 2019/20.

Figure 6.36 provides historical transmission delivered load duration curves for the South West zone. The South West zone is one of two zones in Queensland where the delivered demand reaches negative values, meaning that the embedded generation exceeds the native load, the transmission network supplying the zone is often operated at zero and near zero loading, and the embedded generation makes use of the transmission network to feed loads in other zones. Energy delivered from the transmission network has reduced by 17.0% between 2018/19 and 2019/20. The reduction in energy delivered is due to the increase in energy from embedded generation. The peak transmission delivered demand in the zone was 313MW, which is below the highest maximum demand over the past five years of 343MW set in 2017/18. The minimum transmission delivered demand in the zone was -72MW, which is the lowest demand on record.

Figure 6.36 Historical South West zone transmission delivered load duration curves

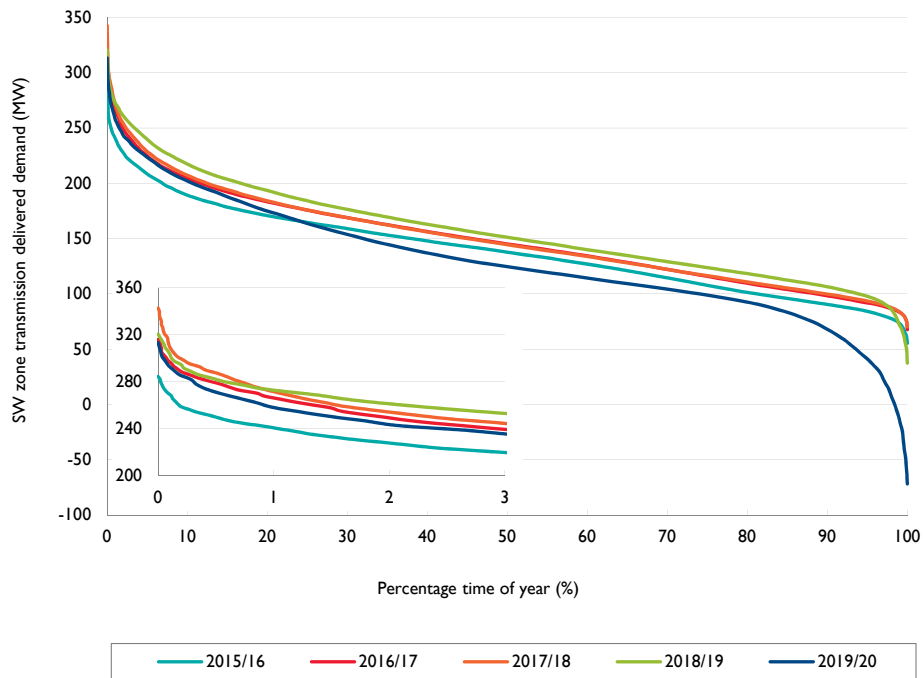

Constraints occur within the South West zone under intact network conditions. These constraints are associated with maintaining power flows of the 110kV transmission lines between Tangkam and Middle Ridge substations within the feeder's thermal ratings at times of high local generation. Powerlink maximises the allowable generation by applying dynamic line ratings to take account of real time prevailing ambient weather conditions. AEMO identifies these constraints with identifiers Q>NIL\_MRTA\_A and Q>NIL\_MRTA\_B. These constraints were implemented in AEMO's market system from April 2010. There were no constraints recorded against this constraint equations in 2019/20. Oakey Power Station's production reduced significantly since 2016/17, in line with other gas fired generators in South West Queensland.

Energy Infrastructure Investments (EII) has advised AEMO of its intention to retire Daandine Power Station in June 2022.

Information pertaining to the historical duration of constrained operation due to these constraints is summarised in Figure 6.37.

# 6 Network capability and performance

**Figure 6.37** Historical Q>NIL\_MRTA\_A and Q>NIL\_MRTA\_B constraint times

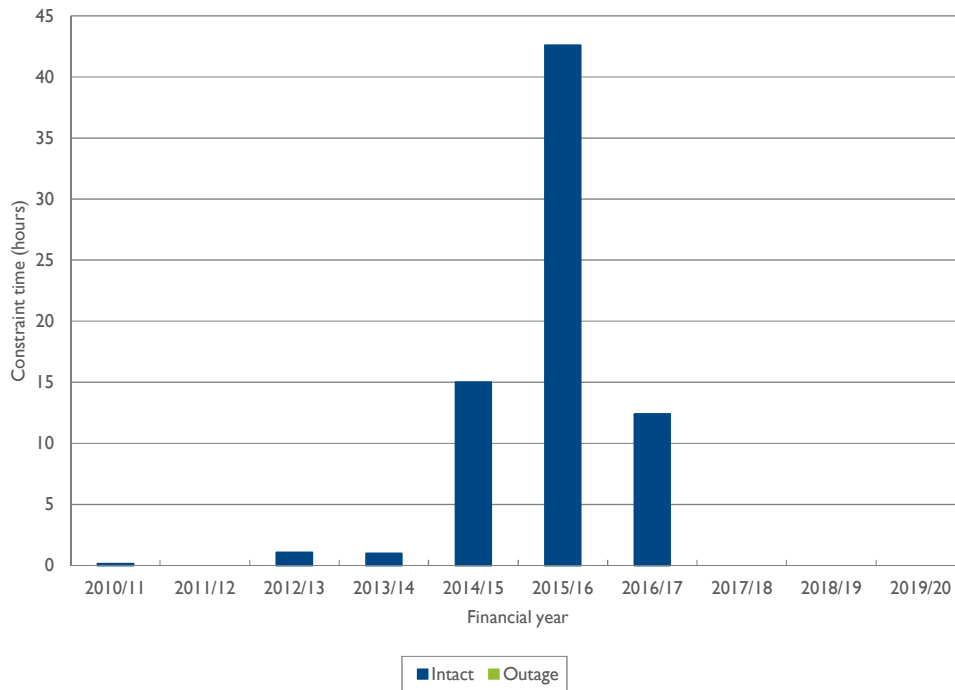

## 6.7.10 Moreton zone

The Moreton zone experienced no load loss for a single network element outage during 2019/20.

The Moreton zone includes the significant non-scheduled embedded generators Sunshine Coast Solar Farm, Bromelton and Rocky Point as defined in Figure 2.6. These embedded generators provided approximately 69GWh during 2019/20.

Figure 6.38 provides historical transmission delivered load duration curves for the Moreton zone. Energy delivered from the transmission network has reduced by 2.5% between 2018/19 and 2019/20. The peak transmission delivered demand in the zone was 4,298W, which is below the highest maximum demand over the past five years of 4,316MW set in 2018/19. The minimum transmission delivered demand in the zone was 786MW which is the lowest demand on record.

**Figure 6.38** Historical Moreton zone transmission delivered load duration curves

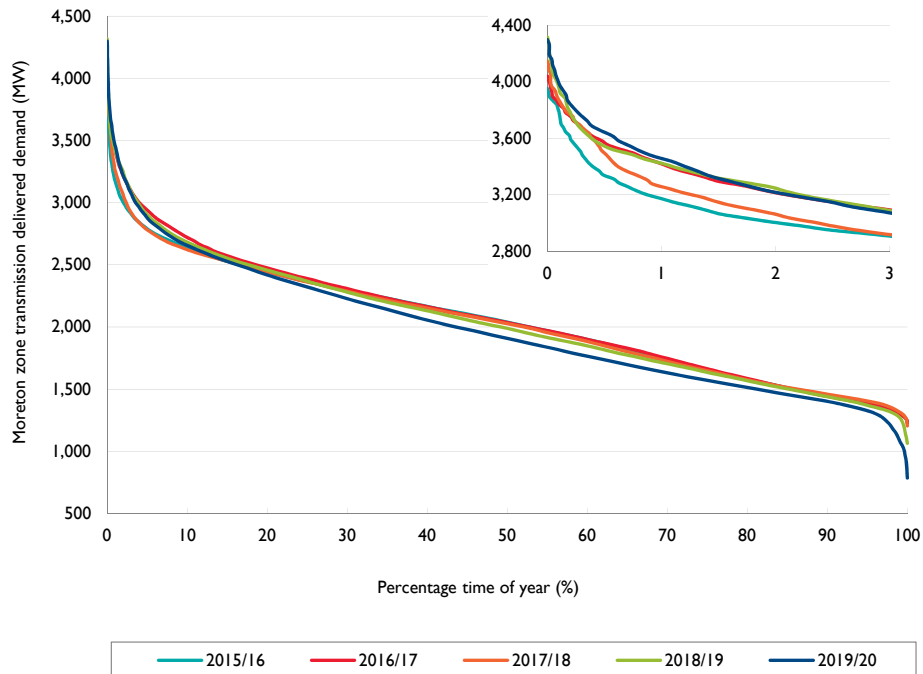

High voltages associated with these light load conditions are currently managed with existing reactive sources. However, voltage control within Powerlink's and Energex's network is forecast to become increasingly challenging for longer durations. This is discussed in Section 5.7.10.

### 6.7.11 Gold Coast zone

The Gold Coast zone experienced no load loss for a single network element outage during 2019/20.

The Gold Coast zone contains no scheduled, semi-scheduled or significant non-scheduled embedded generators as defined in Figure 2.6.

Figure 6.39 provides historical transmission delivered load duration curves for the Gold Coast zone. Energy delivered from the transmission network has reduced by 3.1% between 2018/19 and 2019/20. The peak transmission delivered demand in the zone was 731MW, which is below the highest maximum demand over the last five years of 732MW set in 2018/19. The minimum transmission delivered demand in the zone was 167MW which is the lowest demand on record.

# 6 Network capability and performance

Figure 6.39 Historical Gold Coast zone transmission delivered load duration curves

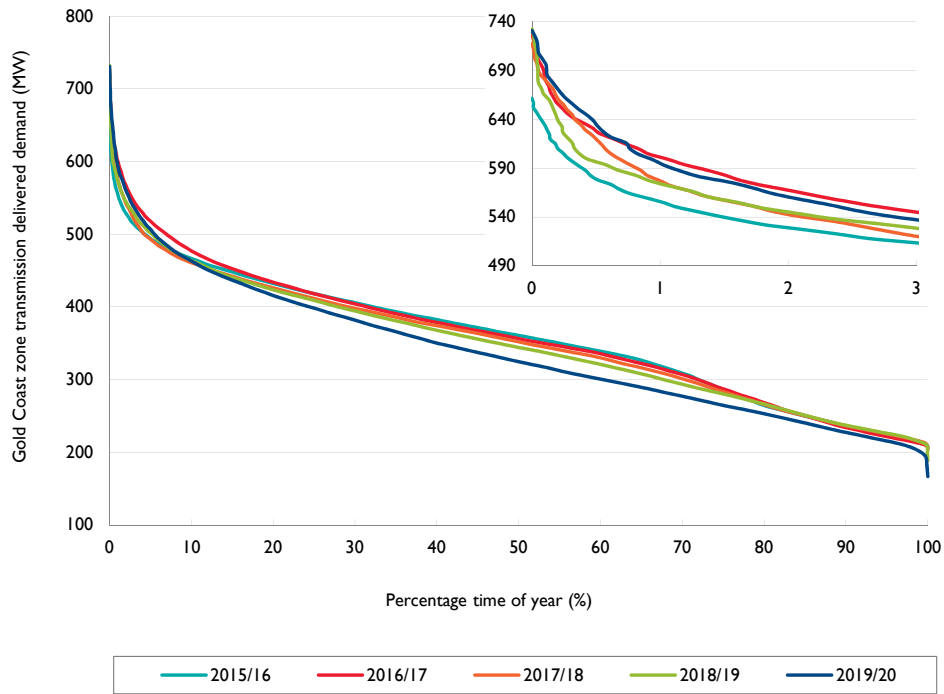

## CHAPTER 7

# Strategic planning

- 7.1 Introduction
- 7.2 Challenges of falling minimum demand
- 7.3 Possible network options to meet reliability obligations for potential new loads
- 7.4 Impact of the energy transformation



# 7 Strategic planning

## Key highlights

- Long-term planning takes into account:
  - the role the transmission network is to play in enabling the transition to a lower carbon future while continuing to deliver a secure, safe, reliable and cost effective service
  - dynamic changes in the external environment, including load growth and the growth in variable renewable energy (VRE) developments in Queensland
  - the condition and performance of existing assets to optimise the network that is best configured to meet current and a range of plausible future capacity needs.
- The high uptake of large-scale VRE generation and rooftop photovoltaic (PV) is significantly changing the daily load profile and presenting challenges to the planning and operability of the transmission system and generation systems required to maintain reliable and efficient market outcomes.
- Plausible new loads within the resource rich areas of Queensland or at the associated coastal port facilities may cause network limitations to emerge within the 10-year outlook period. Possible network options are provided for Bowen Basin coal mining area, Bowen Industrial Estate, Galilee Basin coal mining area, Central Queensland to North Queensland (CQ-NQ) grid section and the Surat Basin north west area.
- The changing generation mix also has implications for investment in the transmission network, both inter-regionally and within Queensland, across critical grid sections. The 2020 Integrated System Plan (ISP) and recent Queensland Government announcements identify the development of Renewable Energy Zones (REZs) that could impact the utilisation and adequacy of the Gladstone and Central Queensland to South Queensland (CQ-SQ) grid sections and Queensland to New South Wales (NSW) Interconnector (QNI).

## 7.1 Introduction

Australia is in the midst of an energy transformation driven by advances in renewable energy technologies, displacement and retirement of existing fossil fuelled generation, changing customer expectations and emission policies.

The future customer load will be supplied by a mix of large-scale generation and distributed energy resources (DER). Queensland is experiencing a high level of growth in VRE generation, in particular solar PV and wind farm generation. During 2019/20, commitments have added 1,498MW to Queensland's semi-scheduled VRE generation capacity (refer to Section 6.2), taking the total to 3,960MW connected, or committed to connect to the Queensland transmission and distribution networks.

Customer behaviour is central to the energy transformation. Customers are demanding choice and the ability to exercise greater control over their energy needs, with consistent expectations of reliability and greater affordability. The future load is also uncertain due to different scenario outlooks, the emergence of new technology, orchestration of significant DER, and the commitment and/or retirement of large industrial and mining loads. These uncertainties have now increased further due to the COVID-19 pandemic and the impact this may have on economic recovery and demand for existing energy-intensive industries.

This energy transformation is creating opportunities and challenges for the power system. The high uptake of large-scale VRE generation, especially PV solar farms, coupled with continued uptake of rooftop PV is having a significant impact on the net daily load profile that is met by conventional fossil-fuelled generators. This will have an impact on the technical operation of these power plants. These emerging power system issues are discussed in Section 7.2.

Chapter 2 provides details of several proposals for large mining, metal processing and other industrial loads whose development status is not yet at the stage that they have been included (either wholly or in part) in the AEMO's ISP Central scenario forecast. These load developments are listed in Table 2.1. Section 7.3 discusses the possible impact these uncertain loads may have on the performance and adequacy of the transmission system.

Australian Energy Market Operator (AEMO)'s ISP identifies the optimal development path over a planning horizon of at least 20 years for the strategic and long-term development of the national transmission system. The ISP establishes a whole of system plan that integrates generation and transmission network developments. The ISP identifies actionable and future projects, and informs market participants, investors, policy decision makers and consumers on a range of development opportunities.

The 2020 ISP has not identified any 'actionable' projects within Queensland. However, the 2020 ISP has identified several projects that may become actionable in future ISPs. Projects identified as part of the optimal development path nominated in the 2020 ISP which relate to Powerlink's transmission network, include:

- QNI Medium and Large interconnector upgrades
- Central to Southern Queensland reinforcement
- Gladstone Grid reinforcement.

Preparatory activities for these projects will be provided by 30 June 2021 to inform the development of the 2022 ISP.

## 7.2 Challenges of falling minimum demand

The high uptake of large-scale VRE generation within the distribution networks together with the significant uptake of rooftop PV is changing the transmission delivered daily load profile to a characteristic 'duck curve' shape (refer Section 2.3.1). These large quantities of solar generation are all highly correlated in output. A noticeable change has been the transition of minimum demand from the very early morning historically to the middle of the day. As embedded and rooftop PV capacity increases, the minimum daytime demand will continue to decrease. Figure 7.1 shows the transition to daytime minimum demands.

**Figure 7.1** Decline of minimum day time transmission delivered demand

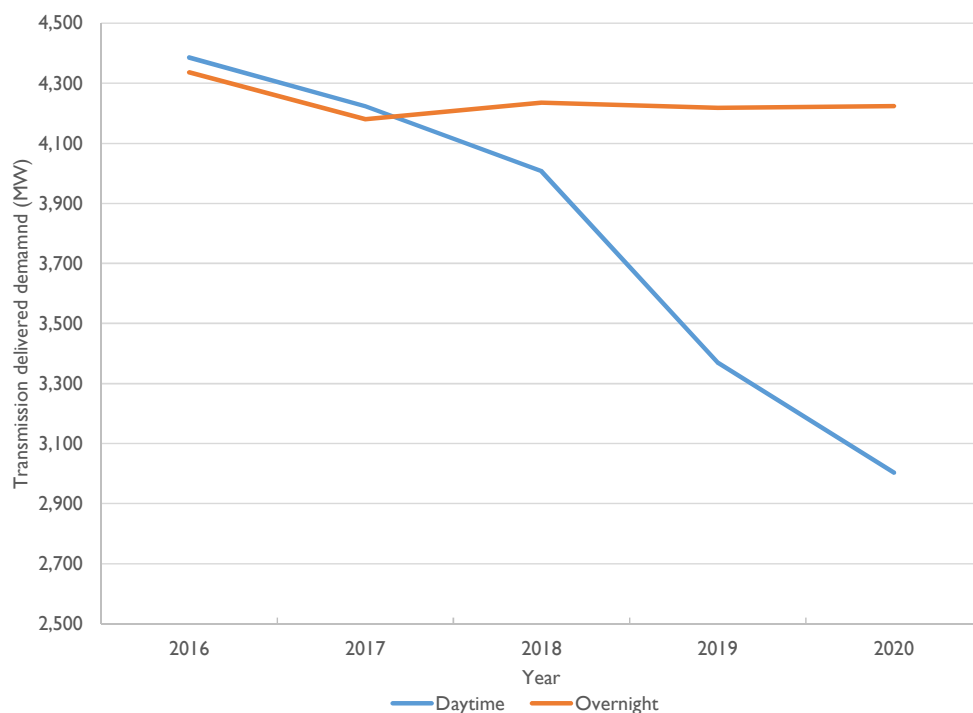

The transmission delivered demand in Figure 7.1 is also partially supplied from transmission connected large-scale solar VRE. Therefore, the load available for supply by the traditional synchronous generation or 'residual demand' is reducing.

## 7 Strategic planning

As the supply side capacity increases with more VRE, evidence has emerged that scheduled synchronous generators are having to reduce their output at times of low electricity demand and high solar generation output. Zero or negative daytime wholesale electricity prices are now regularly observed in response to this increased competition to meet the falling daytime residual demands.

In the absence of energy storage devices (such as household battery systems) or significant levels of demand time of day shifting, minimum demand is expected to further decrease as the uptake of rooftop PV systems continues within residential and commercial premises. However, the maximum daily demand continues to increase in line with underlying load growth since the contribution of rooftop PV tapers off towards the evening. As a result, there is continued widening between maximum and minimum demand.

This trend is likely to present challenges to the power system. Synchronous generators will be required to ramp up and down more frequently in response to daily demand variations. For example, as the rooftop PV ramps down from 4pm in the afternoon, scheduled synchronous generation (and interconnection) need to ramp up to meet the daily peak demand. Figure 7.2 shows the historical average ramp rate that has occurred at the scheduled synchronous generators in the Queensland region. This indicates that the rate of change of synchronous generation required to meet evening peak demand is increasing.

**Figure 7.2** Average ramp rate for evening peak demand

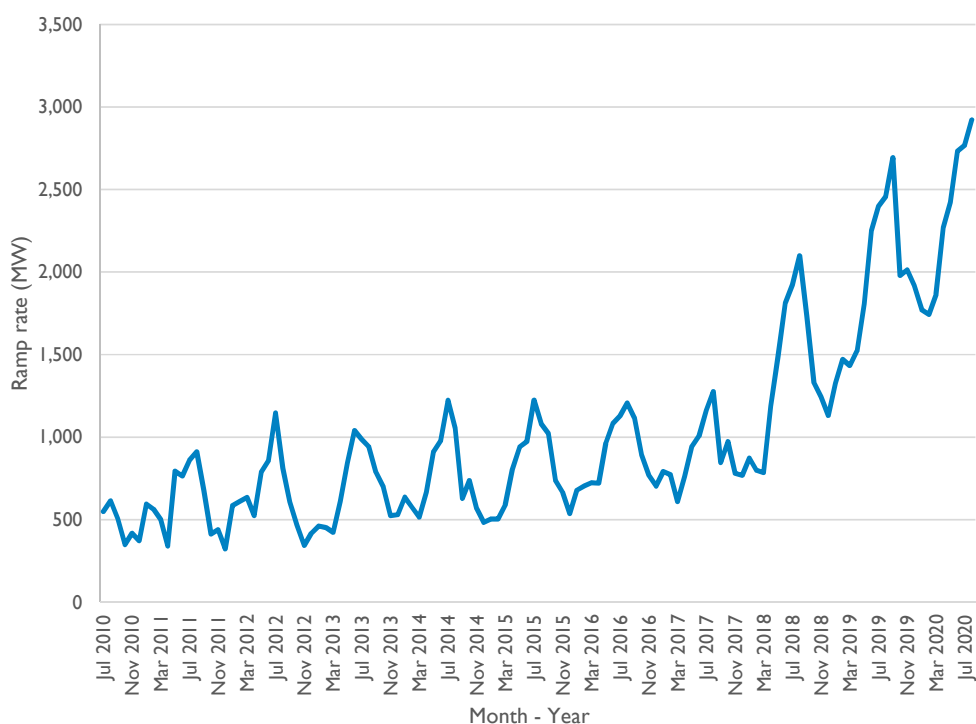

However, generation capacity to meet the evening peaks may become scarce if synchronous generators are being displaced in the middle of the day due to minimum demand or do not have adequate flexibility to ramp up for the evening peak periods. This is likely to progressively increase the reliance on gas-fired generation over peak demand periods.

There may also be opportunities for new technologies and non-network solutions to assist with managing the daily peaks and troughs. Demand shifting and storage solutions have the potential to smooth the daily load profile. These services could offer a number of benefits to the electricity system including reducing the need for additional transmission investment. Additional interconnection capacity may also play a role in meeting the evening peak demand.

As well as energy, synchronous plants provide power system stability services such as frequency control, system strength, inertia, voltage control and damping for power system oscillations. The impacts of the changing generation mix is already leading Powerlink to identify emerging reactive power and voltage control limitations (refer to Section 5.7.4). Many of these broader power system issues are inter-related and solutions need to be examined holistically to ensure an optimal and economic development path. Powerlink is taking an integrated approach to long-term planning of the transmission grid which takes in account the dependency of issues associated with the transitioning power system.

Powerlink is continuing to monitor and assess the impacts of changing load profiles and generation mix on the transmission network, and is taking an integrated planning approach to address emerging issues and challenges with the transitioning power system.

## 7.3 Possible network options to meet reliability obligations for potential new loads

Chapter 2 provides details of several proposals for large mining, metal processing and other industrial loads whose development status is not yet at the stage that they can be included (either wholly or in part) in AEMO's Central scenario forecast.

The new large loads, listed in Table 2.1, are within the resource rich areas of Queensland or at the associated coastal port facilities. The relevant resource rich areas include the Bowen Basin, Galilee Basin, North West Mineral Province (Mt Isa) and Surat Basin. These loads have the potential to significantly impact the performance of the transmission network supplying these areas. The degree of impact is also dependent on the location and capacity of new or withdrawn generation in the Queensland region.

The new load developments in the Bowen Basin and Surat Basin and associated coastal port facilities are embedded within the existing Powerlink transmission system footprint. However, the connection of new loads in the Galilee Basin and the connection of existing loads in the North West Mineral Province will require transmission network extensions to these remote locations.

The commitment of some or all of these loads may cause transmission limitations to emerge on the network. These limitations could be due to plant ratings, voltage stability and/or transient stability. However, all of these loads will have a positive impact on the minimum load issues discussed in Section 7.2. This is particularly since the load profile for these mining, metal processing and industrial loads are typically relatively flat.

Options to address the transmission limitations include network solutions, demand side management (DSM) and generation non-network solutions. Feasible network projects can range from incremental developments to large-scale projects capable of delivering significant increases in power transfer capability.

As the strategic outlook for non-network options is not able to be clearly determined, this section focuses on strategic network developments only. This should not be interpreted as predicting the preferred outcome of the RIT-T process. The recommended option for development, in the RIT-T, is the credible option that maximises the present value of the net economic benefit to all those who produce, consume and transport electricity in the market.

The emergence and magnitude of network limitations resulting from the commitment of these loads will also depend on the location, type and capacity of new or withdrawn generation. For the purpose of this assessment the existing and committed generation in tables 6.1 and 6.2 have been taken into account when discussing the possible network limitations and options. However, where current interest in connecting further VRE generation has occurred, that has the potential to materially impact the magnitude of the emerging limitation, this is also discussed in the following sections. Powerlink will consider these potential limitations holistically with the emerging condition based drivers as part of the longer term planning process and in conjunction with the ISP.

# 7 Strategic planning

Details of feasible network options are provided in sections 7.3.1 to 7.3.5, for the transmission grid sections potentially impacted by the possible new large loads in Table 2.1. Formal consultation via the RIT-T process on the network and non-network options associated with emerging limitations will be subject to commitment of additional demand.

## 7.3.1 Bowen Basin coal mining area

Based on AEMO's Central scenario forecast defined in Chapter 2, the committed network described in Chapter 9, and the committed generation described in tables 6.1 and 6.2 network limitations are not forecast to exceed the limits established under Powerlink's planning standard.

However, there has been a proposal for the development of coal seam gas (CSG) processing load of up to 80MW (refer to Table 2.1) in the Bowen Basin. These loads have not reached the required development status to be included in AEMO's Central scenario forecast for this Transmission Annual Planning Report (TAPR).

The new loads within the Bowen Basin area would result in voltage and thermal limitations on the 132kV transmission system upstream of their connection points. Critical contingencies include an outage of a 132kV transmission line between Nebo and Moranbah substations, or the 132kV transmission line between Lilyvale and Dysart substations (refer to Figure 5.6).

The impact these loads may have on the CQ-NQ grid section and possible network solutions to address these is discussed in Section 7.3.4.

### Possible network solutions

Feasible network solutions to address the limitations are dependent on the magnitude and location of load. The location, type and capacity of future VRE generation connections in North Queensland (NQ) may also impact on the emergence and severity of network limitations. The type of VRE generation interest in this area is predominately large-scale solar PV. Given that the CSG load profile would be expected to be relatively flat, it is unlikely that the daytime PV generation profile will be able to successfully address all emerging limitations.

Depending on the magnitude and location of load, possible network options may include one or more of the following:

- 132kV phase shifting transformers to improve the sharing of power flow in the Bowen Basin within the capability of the existing transmission assets
- construction of 132kV transmission lines between the Nebo, Broadlea and Peak Downs areas
- construction of 132kV transmission line between Moranbah and a future substation north of Moranbah.

## 7.3.2 Bowen Industrial Estate

Based on AEMO's Central scenario forecast defined in Chapter 2, no additional capacity is forecast to be required as a result of network limitations within the 10-year outlook period of this TAPR.

However, electricity demand in the Abbot Point State Development Area (SDA) is associated with infrastructure for new and expanded mining export and value adding facilities. Located approximately 20km west of Bowen, Abbot Point forms a key part of the infrastructure that will be necessary to support the development of coal exports from the northern part of the Galilee Basin. The loads in the SDA could be up to 100MW (refer to Table 2.1) but have not reached the required development status to be included in AEMO's Central scenario forecast.

The Abbot Point area is supplied at 66kV from Bowen North Substation. Bowen North Substation was established in 2010 with a single 132/66kV transformer and supplied from a double circuit 132kV transmission line from Strathmore Substation but with only a single transmission line connected. During outages of the single 132kV supply to Bowen North the load is supplied via the Ergon Energy 66kV network from Proserpine, some 60km to the south. An outage of the 132kV single connection during high load will cause voltage and thermal limitations impacting network reliability.

**Possible network solutions**

A feasible network solution to address the limitations comprises:

- installation of a second 132/66kV transformer at Bowen North Substation and connection of the second Strathmore to Bowen North 132kV transmission line.

**7.3.3 Galilee Basin coal mining area**

There have been proposals for new coal mining projects in the Galilee Basin. Although these loads could be up to 400MW (refer to Table 2.1) none have reached the required development status to be included in AEMO's Central scenario forecast for this TAPR. If new coal mining projects eventuate, voltage and thermal limitations on the transmission system upstream of their connection points may occur.

Depending on the number, location and size of coal mines that develop in the Galilee Basin it may not be technically or economically feasible to supply this entire load from a single point of connection to the Powerlink network. New coal mines that develop in the southern part of the Galilee Basin may connect to Lilyvale Substation via an approximate 200km transmission line. Whereas coal mines that develop in the northern part of the Galilee Basin may connect via a similar length transmission line to the Strathmore Substation.

Whether these new coal mines connect at Lilyvale and/or Strathmore Substation, the new load will impact the performance and adequacy of the CQ-NQ grid section. Possible network solutions to the resultant CQ-NQ limitations are discussed in Section 7.3.4.

In addition to these limitations on the CQ-NQ transmission system, new coal mine loads that connect to the Lilyvale Substation may cause thermal and voltage limitations to emerge during an outage of a 275kV transmission line between Broadsound and Lilyvale substations.

**Possible network solutions**

For supply to the Galilee Basin from Lilyvale Substation, feasible network solutions to address the limitations are dependent on the magnitude of load and may include one or both of the following options:

- installation of capacitor bank/s at Lilyvale Substation
- third 275kV transmission line between Broadsound and Lilyvale substations.

The location, type and capacity of future VRE generation connections in Lilyvale, Blackwater and Bowen Basin areas may impact on the emergence and severity of this network limitation. The type of VRE generation interest in this area is predominately large-scale solar PV. Given that the coal mining load profile would be relatively flat, it is unlikely that the daytime PV generation will be able to successfully address all emerging limitations.

**7.3.4 CQ-NQ grid section transfer limit**

Based on AEMO's Central scenario forecast outlined in Chapter 2 and the committed generation described in tables 6.1 and 6.2, network limitations impacting reliability are not forecast to occur within the 10-year outlook of this TAPR. However, midday power transfer levels are reversing from northern to southern transfers. The incidence of light loading on the transmission system is forecast to increase as additional VRE generators are fully commissioned in NQ. Voltage control is therefore forecast to become increasingly challenging and lead to high voltage violations. As outlined in Section 5.7.4 a possible network solution to the voltage control limitation is the installation of a shunt bus reactor.

As discussed in sections 7.3.1, 7.3.2 and 7.3.3 there have been proposals for large coal mine developments in the Galilee Basin, and development of CSG processing load in the Bowen Basin and associated port expansions. There is also the potential load in the North West Mineral Province. If connected this load would connect to a new substation south of Powerlink's Ross Substation. The combined loads could be up to 930MW (refer to Table 2.1) but have not reached the required development status to be included in AEMO's Central scenario forecast of this TAPR.

## 7 Strategic planning

Network limitations on the CQ-NQ grid section may occur if a portion of these new loads commit. Power transfer capability into northern Queensland is limited by thermal ratings or voltage stability. Thermal limitations may occur on the Bouldercombe to Broadsound 275kV line during a critical contingency of a Stanwell to Broadsound 275kV transmission line. Voltage stability limitations may occur following the trip of the Townsville gas turbine or 275kV transmission line supplying northern Queensland.

Currently generation costs for the majority of synchronous generation in NQ are high. As a result, there may be positive net market benefits in augmenting the transmission network. The current commitment of VRE generation in NQ and any future uptake of VRE generation would be taken into account in the market benefit assessment, including consideration of the location, type and capacity of these future connections.

### Possible network solutions

In 2002, Powerlink constructed a 275kV double circuit transmission line from Stanwell to Broadsound with one circuit strung (refer to Figure 7.3). A feasible network solution to increase the power transfer capability to northern Queensland is to string the second side of this transmission line.

**Figure 7.3** Stanwell/Broadsound area transmission network

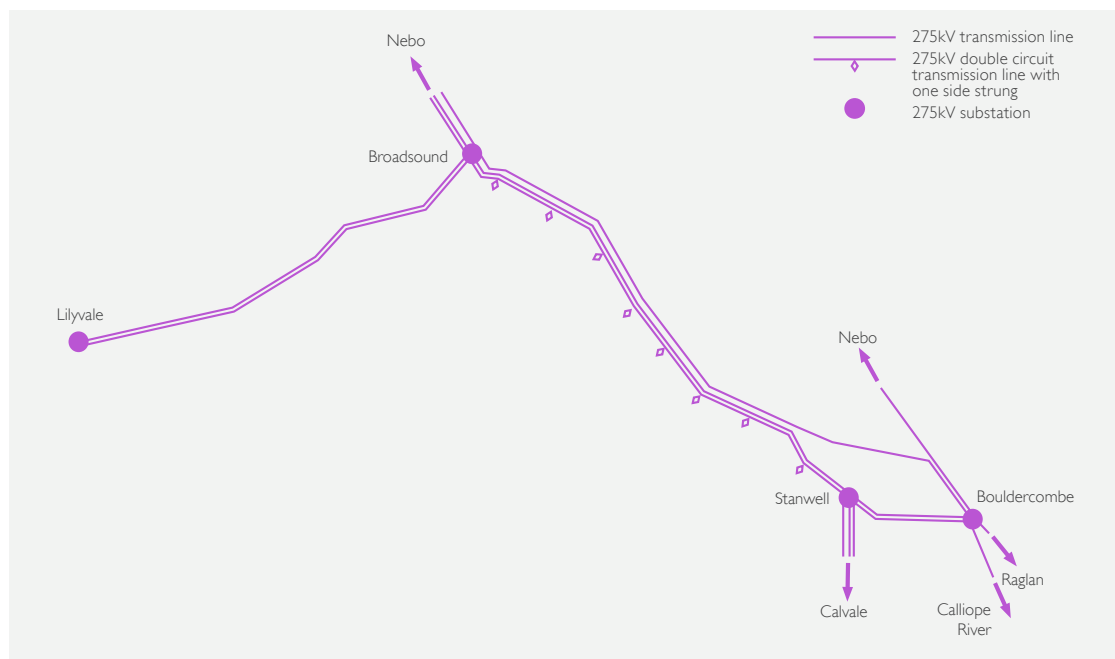

### 7.3.5 Surat Basin north west area

Based on AEMO's Central scenario forecast defined in Chapter 2, network limitations impacting reliability are not forecast to occur within the next five years of this TAPR.

However, there have been several proposals for additional CSG upstream processing facilities and new coal mining load in the Surat Basin north west area. These loads have not reached the required development status to be included in AEMO's Central scenario forecast for this TAPR. The loads could be up to 300MW (refer to Table 2.1) and cause voltage limitations impacting network reliability on the transmission system upstream of their connection points.

Depending on the location and size of additional load, voltage stability limitations may occur following outages of the 275kV transmission lines between Western Downs and Columboola, and between Columboola and Wandoan South substations (refer to Figure 7.4).

### Possible network solutions

Due to the nature of the voltage stability limitation, the size and location of load and the range of contingencies over which the instability may occur, it may not be possible to address this issue by installing a single Static VAR Compensator (SVC) at one location.

The location, type and capacity of future VRE generation connections in the Surat Basin north west area may also impact on the emergence and severity of these voltage limitations. The type of VRE generation interest in this area is large-scale solar PV. Given that the CSG upstream processing facilities and new coal mining load has a predominately flat load profile it is unlikely that the daytime PV generation profile will be able to successfully address all emerging voltage limitations. However, voltage limitations may be ameliorated by these renewable plants, particularly if they are designed to provide voltage support 24 hours a day.

To address the voltage stability limitation the following network options are viable:

- SVCs, Static Synchronous Compensators (STATCOM) or Synchronous Condensers (SynCon) at both Columboola and Wandoan South substations
- additional transmission lines between Western Downs, Columboola and Wandoan South substations to increase fault level and transmission strength, or
- a combination of the above options.

**Figure 7.4** Surat Basin north west area transmission network

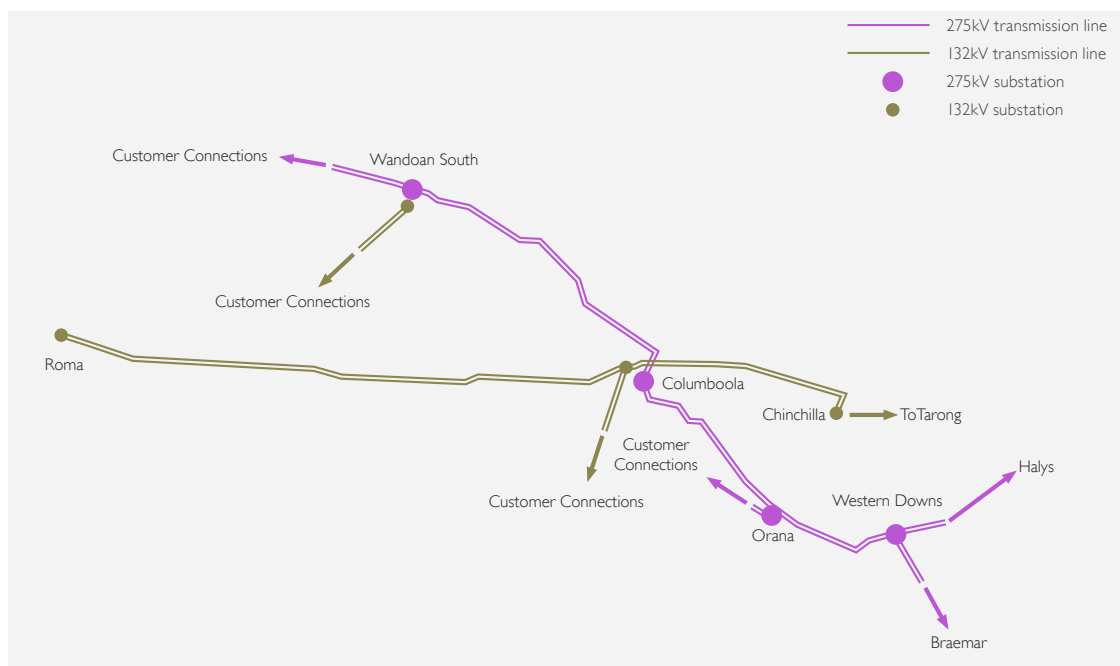

## 7.4 Impact of the energy transformation

The installation of large-scale VRE generation is changing the mix of generation and impacting the utilisation of existing transmission infrastructure. This has been most evident across the Central to NQ and Central to South Queensland grid sections (refer sections 6.6.2 and 6.6.5 respectively) and the Queensland to NSW interconnector (QNI). This has implications for investment in the transmission network both inter-regional and within Queensland.



# 7 Strategic planning

These impacts have been investigated in AEMO's 2020 ISP. The 2020 ISP has identified that in order to deliver low-cost, secure and reliable energy, investments in transmission are needed. Although no 'actionable' projects were identified for Queensland, several Queensland projects were identified as part of the optimal development path that may become 'actionable' in future ISPs. These projects will be vital to achieving lower cost solutions that meet energy security and reliability, affordability and reduced emissions. These projects include:

- QNI Medium and Large interconnector upgrades
- Central to Southern Queensland transmission reinforcement
- Gladstone grid section reinforcement.

Preparatory activities for these projects will be provided by 30 June 2021 to inform the development of the 2022 ISP.

## 7.4.1 Queensland to NSW Interconnector (QNI)

Increasing the capacity of interconnection between National Electricity Market (NEM) regions is essential in order to take advantage of the geographic diversity of renewable resources so regions can export power when there is local generation surplus, and import power when needed to meet demand. Appropriate intra-regional transmission capacity is also required to support these objectives.

As outlined in Section 5.7.14 Powerlink and TransGrid released a Project Assessment Conclusion Report on 'Expanding NSW-Queensland transmission transfer capacity' in December 2019. The recommended QNI Minor option (uprating the 330kV Liddell to Tamworth 330kV lines, and installing SVCs at Tamworth and Dumaresq substations and static capacitor banks at Tamworth, Armidale and Dumaresq substations) is now committed and is expected to be completed by June 2022 at a cost of \$217 million. All material works associated with this minor upgrade are within TransGrid's network.

The 2020 ISP identified that a further staged upgrade to the transmission capacity between Queensland and NSW (QNI Medium and QNI Large) was an integral part of the optimal development plan. The 2020 ISP identified that the additional transmission capacity would deliver net market benefits from:

- efficiently maintaining supply reliability in NSW following the closure of further generation and the decline in ageing generator reliability
- facilitating efficient development and dispatch of generation in areas with high quality renewable resources through improved network capacity and access to demand centres
- enabling more efficient sharing of resources between NEM regions.

These options can also be optimised with capacity to REZ developments and can be staged by geography, operating voltage and number of circuits to maximise net economic benefits.

The proposed project is a staged 500kV line upgrade to share renewable energy, storage, and firming services between the regions after the closure of Eraring or to support REZ developments. Each stage is a 500kV line; the first forecast for completion by 2032-33 and the second by 2035-36.

The 2020 ISP concluded that this project would reduce system costs, and enhance system resilience and optionality. The project is not yet 'actionable' under the new ISP Rules, but is expected to become actionable in the future. Preparatory activities, as outlined above, are to be completed by 30 June 2021 so that costs and capacity improvements can be included in the 2022 ISP.

### Possible network solutions

The QNI Medium upgrade project proposed by AEMO as part of the optimal development path includes a single 500kV circuit between Queensland and NSW via the western part of the existing QNI. The proposed route traverses the North West New South Wales and Darling Downs REZs.

Specifically, QNI Medium includes:

- a single 500kV circuit between New South Wales and Queensland strung on double circuit towers via the western part of the existing QNI including terminal stations and supporting plant.
- the proposed route goes through North West New South Wales and Darling Downs REZs.

This augmentation can be expanded with a second stage to form the QNI Large upgrade.

QNI Large comprises:

- a second 500kV circuit between New South Wales and Queensland strung on the double circuit tower which was proposed in QNI medium stage.

AEMO also flagged in the 2020 ISP that it will work with Powerlink and TransGrid to explore further options in relation to Virtual transmission lines (VTLs). The 2020 ISP outlined that VTLs, coupled with suitable wide area protection systems, could provide a technically feasible solution to increase the capacity of QNI. A VTL could comprise of grid-scale batteries on both sides of a QNI (for bidirectional limit increases), or a grid-scale battery on one side and braking resistor or generator tripping on the other side (for unidirectional limit increases).

Powerlink and TransGrid anticipate commencing preliminary activities to assess the economic benefits of further upgrades to the QNI capacity (refer to Section 5.7.14).

#### 7.4.2 CQ-SQ grid section reinforcement

In order for power from new and existing NQ and CQ VRE generating systems to make its way to southern Queensland and the southern states, it must be transferred through the CQ-SQ grid section. The utilisation of the CQ-SQ grid sections is therefore expected to increase (refer to Section 5.7.6 and Section 6.6.5) and may lead to levels of congestion depending on the response of the central and northern Queensland generators to the energy market. In addition, the utilisation may also increase following the commissioning of the QNI Minor project (refer to Section 5.7.14).

As outlined in Section 7.4.1, the 2020 ISP has identified a further upgrade of QNI capacity from 2032/33. The utilisation and adequacy of the CQ-SQ grid section is closely linked to the required efficient capacity of interconnection with NSW.

As outlined in Section 5.7.6 there are emerging condition and compliance risks related to structural corrosion on significant sections of the coastal CQ-SQ 275kV network between Calliope River and South Pine substations. Strategies to address the transmission line sections with advanced corrosion in the five year outlook are described in Section 5.7.6.

In parallel, Powerlink and AEMO (through the ISP process) continue to investigate the impact of large-scale VRE generation investment in the Queensland region on the utilisation and economic performance of intra-regional grid sections, and in particular the CQ-SQ grid section. The 2020 ISP identified the need for a material upgrade of CQ-SQ as part of the optimal development path. The 2020 ISP identified the early 2030s as the project timing. The upgrade is critical for unlocking renewable resources the Far North, Isaac, and Fitzroy REZs for efficient market outcomes.

Powerlink will consider the emerging and forecast constraints holistically with the emerging condition based drivers as part of the planning process. Such decisions will be undertaken using the RIT-T consultation process, where the benefits of non-network options will also be considered.

##### Possible network solutions

Feasible network solutions to facilitate efficient market operation may differ in scale. The 2020 ISP identified the need for a material upgrade. The proposed project by AEMO included a new 275kV double circuit transmission line between Calvale and Wandoan South substations.

As outlined in 7.4.1, Powerlink and TransGrid anticipate commencing preliminary activities to assess the economic benefits of further upgrades to the QNI capacity. Due to the linkages between the proposed REZ developments in Far North, Isaac, and Fitzroy and the utilisation and adequacy of the Central West to Gladstone and CQ-SQ grid sections and interconnection with NSW, these issues will be assessed holistically within this new RIT-T process.

# 7 Strategic planning

As a result, additional network options that deliver a range of additional capacity improvements will be considered in addition to the 2020 ISP's new 275kV double circuit on option. These include:

- establishing a mid-point switching substation on the 275kV double circuit between Calvale and Halys substations
- reduce the series impedance of the 275kV double circuit between Calvale and Halys substations via a variety of technologies
- a grid-scale storage system. A VTL option could comprise of grid-scale batteries on both sides of CQ-SQ, or a grid-scale battery on the south side and a braking resistor or generator tripping on the northern side.

## 7.4.3 Gladstone grid section reinforcement

The 275kV network forms a triangle between the generation rich nodes of Calvale, Stanwell and Calliope River substations. This triangle delivers power to the major 275/132kV injection points of Calvale, Bouldercombe (Rockhampton), Calliope River (Gladstone) and Boyne Island substations.

Since there is a surplus of generation within this area, this network is also pivotal to supply power to northern and southern Queensland. As such, the utilisation of this 275kV network depends not only on the generation dispatch and supply and demand balance within the Central West and Gladstone zones, but also in northern and southern Queensland.

Based on AEMO's Central scenario forecast defined in Chapter 2 and the existing and committed generation in tables 6.1 and 6.2, network limitations impacting reliability are not forecast to occur within the 10-year outlook period of this TAPR. This assessment also takes into consideration the retirement of the Callide A to Gladstone South 132kV double circuit transmission line (refer to Section 5.7.5).

However, the committed VRE generation in tables 6.1 and 6.2 in NQ is expected to increase the utilisation of this grid as generation in the Gladstone zone or southern Queensland is displaced. While not impacting reliability of supply, the committed VRE generation in NQ has the potential to cause congestion depending on how the thermal generating units in CQ bid to meet the NEM demand.

In addition, new loads in the resource rich areas of the Bowen Basin, Galilee Basin, North West Mineral Province and Surat Basin has the potential to further significantly increase the utilisation of this grid section. This may lead to significant limitations impacting efficient market outcomes.

Furthermore, the 2020 ISP has identified significant increases in VRE generation for the Far North, Isaac, and Fitzroy REZs (refer to Figure 7.5). With this generation the thermal capacity of the network between Bouldercombe, Raglan, Larcom Creek, and Calliope River will be reached. Upgrading this grid section is therefore critical for unlocking these renewable resources in these REZs as part of the optimal development path. The 2020 ISP identified the 2030s as the project timing. The timing could be brought forward with retirement of Gladstone generation<sup>1</sup>.

### Possible network solutions

Depending on the emergence of network limitations within the 275kV network it may become economically viable to increase its power transfer capacity to alleviate constraints. Feasible network solutions to facilitate efficient market operation may include:

- transmission line augmentation between Calvale and Larcom Creek substations and rebuild between Larcom Creek and Calliope River substations with a high capacity 275kV double circuit transmission line
- rebuild between Larcom Creek, Raglan, Bouldercombe and Calliope River substations with a high capacity 275kV double circuit transmission line
- third Calliope River 275/132kV transformer.

---

<sup>1</sup> The potential closure of a large industrial load in the Gladstone zone also influences the required size and timing of this project.

#### 7.4.4 Renewable Energy Zones (REZ)

As the NEM transforms away from synchronous generation and towards VRE, an additional 34GW to 47GW of new VRE needs to be installed depending on the ISP scenario. This is allowing for strong growth in DER and the large-scale VRE that is already installed or expected to be operational. In Queensland, under AEMO's Central scenario, approximately 11GW of large-scale VRE still needs to be installed by the early 2040s.

A number of REZ development opportunities for the Queensland region have been identified in the ISP's optimal development path. Under the Central scenario, additional VRE generation is planted in five out of eight candidate REZs; Far North Queensland (FNQ), Isaac, Fitzroy, Wide Bay and Darling Downs (refer to Figure 7.5).

These REZs are developed in phases. Initially VRE developments are planted to help meet Queensland's Renewable Energy Target (QRET). The additional VRE is planted where there is relatively good access to existing network capacity and system strength. The 2020 ISP identified wind and solar generation in the Darling Downs and Fitzroy REZs using this existing transmission capacity.

Finally VRE developments are associated with future ISP projects. Larger VRE development in the Fitzroy REZ (wind and solar) and Isaac REZ (wind) are supported by future ISP projects which include the Gladstone and Central to Southern Queensland grid section reinforcements and expansions of QNI (refer to sections 7.4.1, 7.4.2 and 7.4.3). Renewable developments in the FNQ REZ also require 275kV upgrades within this REZ.

In recognition of the potential value of REZ developments across Queensland (the three REZs in north, central and southern zones that overlay the REZs identified in the ISP), the Queensland Government announced \$145 million for REZ support. Powerlink will continue to work with Government, AEMO, stakeholders and customers to drive the most efficient and cost-effective outcomes from this process.

# 7 Strategic planning

Figure 7.5 2020 ISP Renewable Energy zone candidates in Queensland

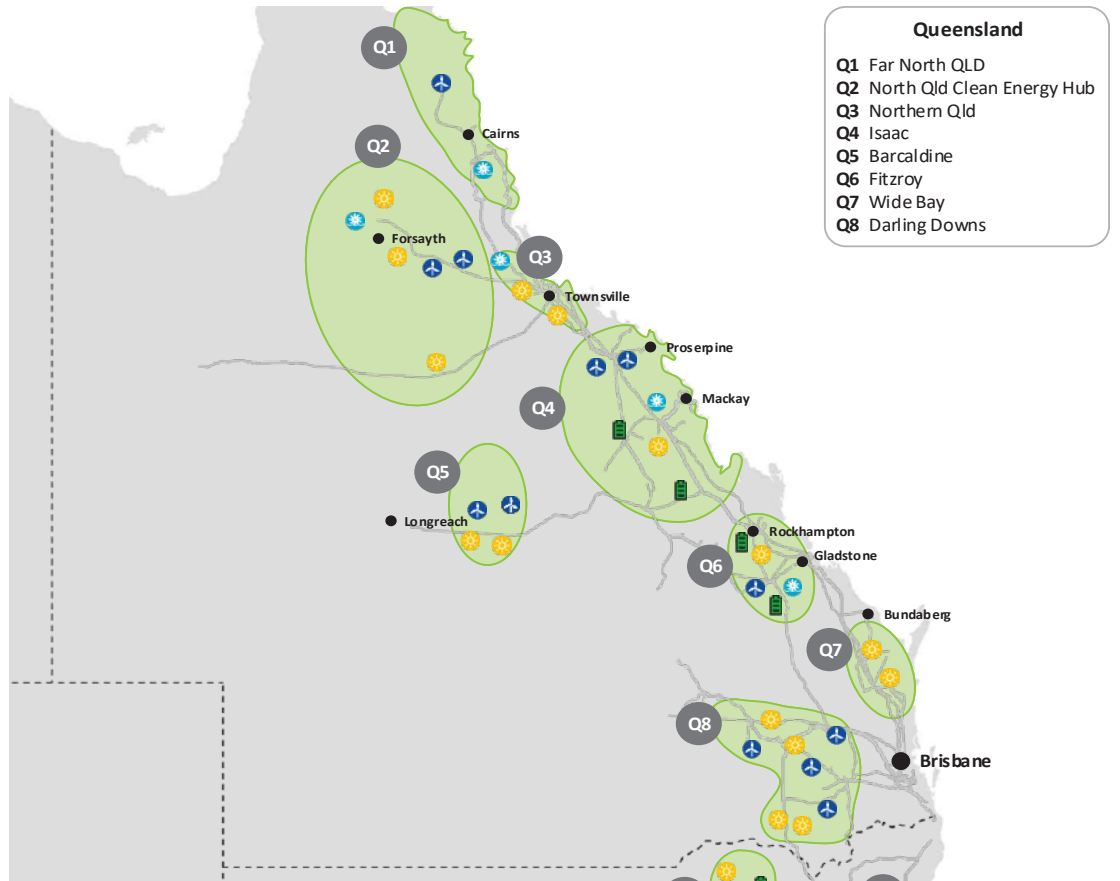

Source: AEMO

## **CHAPTER 8**

# Renewable energy

- 8.1 Introduction
- 8.2 Management of system strength and NER obligations
- 8.3 Developing an understanding of the system strength challenges
- 8.4 Declaration of fault level shortfall
- 8.5 Transmission connection and planning arrangements
- 8.6 Indicative available network capacity - Generation Capacity Guide
- 8.7 System strength during network outages
- 8.8 Transmission congestion and Marginal Loss Factors
- 8.9 Further information

# 8 Renewable energy

## Key highlights

- This chapter explores the potential for the connection of variable renewable energy (VRE) generation to Powerlink's transmission network.
- Powerlink has a central role in enabling the connection of VRE infrastructure in Queensland.
- System strength has been a focus for VRE generators and Powerlink, including development of the Electromagnetic Transient Type (EMT-type) model for Queensland.
- An immediate fault level shortfall has been declared by Australian Energy Market Operator (AEMO) in North Queensland (NQ). Powerlink continues to work with AEMO to develop technical and economic solutions to address the shortfall.
- Powerlink is actively engaging in the Australian Energy Market Commission (AEMC) System Strength Frameworks Review to improve outcomes for connecting parties.

## 8.1 Introduction

Queensland is rich in a diverse range of renewable resources – solar, wind, geothermal, biomass and hydro. This makes Queensland an attractive location for large-scale VRE generation development projects. During 2019/20, 1,498MW of semi-scheduled VRE generation capacity was committed in the Queensland region, taking the total to 3,960MW that is connected, or committed to connect, to the Queensland transmission and distribution networks (refer to Section 6.2). In addition to the large-scale VRE generation development projects rooftop solar in Queensland exceeded 3,285MW in June 2020.

Figure 8.1 shows the location and type of VRE generators connected and committed to connect to Powerlink's network. Department of Natural Resources, Mines and Energy (DNRME) also provides mapping information on proposed (future) VRE projects, together with existing generation facilities (and other information) on its website. For the latest information on proposed VRE projects and locations in Queensland, please refer to the [DNRME website](#).

Figure 8.1 Powerlink’s VRE connections as at July 2020

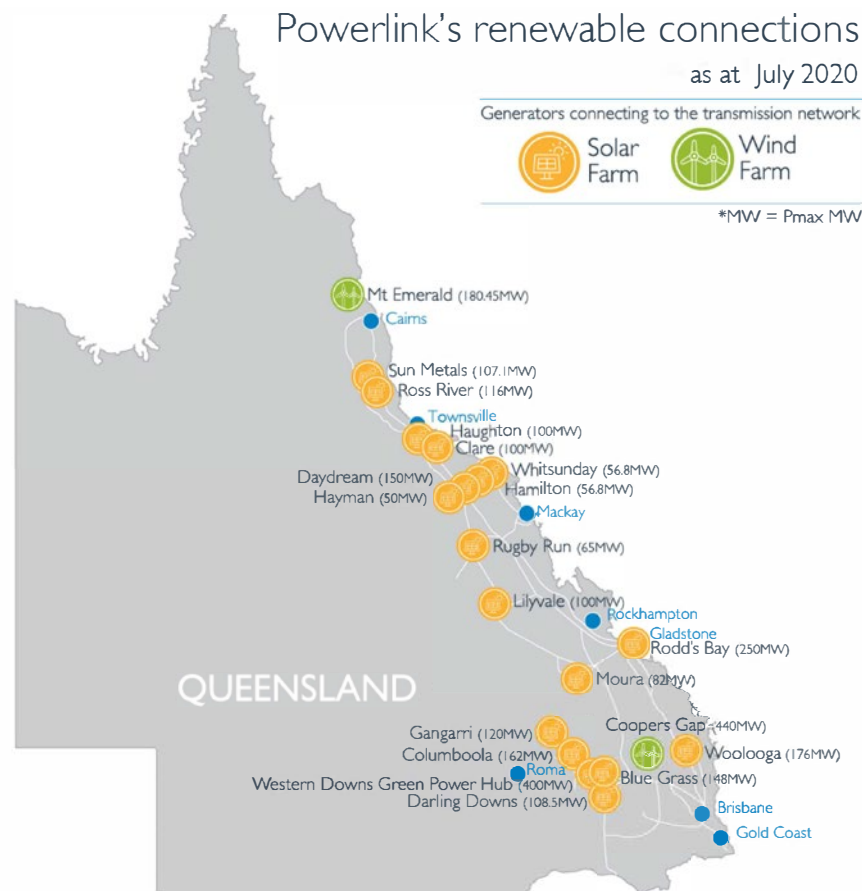

Utility scale and rooftop connections of VRE generation, both in Queensland and the rest of the National Electricity Market (NEM), has brought with it a number of challenges to which Powerlink is responding. One of the main contributors to this challenging environment is system strength. The distributed nature of VRE generation is also changing the way the transmission network is operated, including changes to flow patterns and network utilisation.

This chapter provides information on:

- the current system strength obligations placed on Powerlink and connecting proponents of large-scale inverter-based plant under the National Electricity Rules (NER)
- the objectives of the AEMC’s investigation into System Strength Frameworks and Powerlink’s perspectives
- how Powerlink has and continues to meet the system strength challenges
- the fault level shortfall declared by AEMO in April 2020 and how Powerlink is addressing this shortfall
- the current system strength environment and the opportunities for future investment in VRE generation.

## 8.2 Management of system strength and NER obligations

On 1 July 2018, the AEMC rule for ‘Managing Power System Fault Levels’ came into effect. The Rule provides for a holistic, flexible and technology neutral solution to issues arising from the forecast reduction in system strength.



# 8 Renewable energy

Under the Rule

- AEMO develops a system strength requirements methodology guideline and determines where the fault level nodes are in each region, plus the minimum three phase fault levels and any projected fault level shortfalls at those fault level nodes.
- Transmission Network Service Providers (TNSPs) or jurisdictional planning bodies, as the System Strength Service Providers for each region, are responsible for procuring system strength services to meet a fault level shortfall declared by AEMO. These services must be made available by a date nominated by AEMO which is at least 12 months from the declaration of the shortfall, unless an earlier date is agreed with the System Strength Service Provider.
- Network Service Providers (NSPs) undertake system strength impact assessments to determine whether a proposed new or altered generation or market network service facility connection to their network will result in an adverse system strength impact.
- Applicants pay for system strength connection works undertaken by a NSP to address an adverse system strength impact caused by their proposed connection to the NSP's network or propose a system strength remediation scheme<sup>1</sup>.

Consistent with this methodology, Powerlink worked with AEMO to determine the required minimum fault level at key 'fault level nodes' within the Powerlink network (refer to Table 8.1). The minimum fault level is used to assess that the system can be operated safely and reliably now and into the future. The initial assessment was completed in mid-2018.

The guidelines require the minimum fault level to be reassessed no more than once in every 12 month period to determine whether a fault level shortfall exists or is likely to exist in the future. This assessment considers the displacement<sup>2</sup> of existing synchronous plant in Queensland.

## 8.2.1 Investigation into system strength frameworks by AEMC

Powerlink considers that the existing minimum system strength and 'do no harm' framework is at best reactive and does not provide sufficient time to remediate system strength shortfalls. As such the existing framework is not suited to the speed of the energy transformation occurring.

In October 2020 the AEMC concluded an investigation into the effectiveness of the current framework for the management of system strength. The investigation considered whether any improvements could be made to:

- more effectively identify and address low levels of system strength as they arise in NEM regions, to help maintain system security at the lowest possible cost
- allow for the provision of increased levels of system strength to enable greater output from lower cost generation sources, to deliver lower cost electricity for consumers.
- increase the transparency and efficiency for remediating the system strength effects from large numbers of new connecting generators. This will help make the process of connecting generators more effective, to facilitate the transition to the high renewables grid of the future.

Powerlink actively contributed to the AEMC review and consider that any future framework should take into account:

- an increased emphasis on medium to long-term planning for system strength needs

The energy mix is rapidly transforming and system strength is an issue now but solutions require sufficient time to be delivered. The current short-term reactive approach to deliver a theoretical minimum system strength level is not workable and does not sufficiently enable planning for the long-term management of issues.

---

<sup>1</sup> Obligation on the connecting generator to 'do no harm' came into effect 17 November 2017 with AEMO publishing the 'Interim System Strength Impact Assessment Guidelines'.

<sup>2</sup> Displacement may occur for periods when it is not economic for a synchronous generator to operate, and is distinct from retirement which is permanent removal from the market.

- the adoption of suitable margins for system strength requirements whilst ensuring efficient outcomes  
This includes the need to securely operate the power system under a wide range of operating conditions. To facilitate this the frameworks need to provide for a degree of headroom and inclusion of a stronger operational overlay on the forward planning requirements.

Given the AEMC investigation has only just been finalised, Powerlink is currently reviewing the AEMC recommendation. Powerlink will continue to contribute to the development of new Rules to give effect to changes to the framework. Draft Rules are expected in December 2020.

## 8.3 Developing an understanding of the system strength challenges

Powerlink continues to better understand the system strength challenges and has worked closely with AEMO, Australian Renewable Energy Agency (ARENA) and inverter manufacturers to maximise the VRE generation hosting capacity of the Queensland transmission network.

Fundamental to the understanding of system strength challenges has been the development of a system-wide EMT-type model. This has allowed the study of system strength and its impact on the stability and performance of the power system.

Powerlink has developed an EMT-type model that extends from Far North Queensland (FNQ) to the Hunter Valley in New South Wales (NSW). It includes plant specific models for all VRE and synchronous generators (including voltage control systems) and transmission connected dynamic voltage control plant (Static Var Compensators and Statcoms). This is the most detailed modelling possible with the inverter-based plants modelled at the controller level and with time steps required in micro-seconds.

AEMO's System Strength Impact Assessment Guidelines introduced a Preliminary impact assessment (PIA) screening based on fault level calculation in 2018. This methodology was developed based on the best available knowledge of system strength at that time. During the last 24 months, Powerlink has gained a greater understanding of system strength related issues and now believes that this fault level based methodology does not provide sufficient confidence as a screening methodology, as intended.

Powerlink now understands that the dominant limitation to hosting capacity is the potential for multiple generators, and other transmission connected dynamic plant, to interact in an unstable manner. These dynamic plant control interactions manifest as an unstable or undamped oscillation in the power system voltage. The frequency of the oscillation is dependent on the participating plants, but is broadly characterised as between 8Hz and 15Hz. The only way to gain an understanding of these oscillations is through detailed, EMT-type system-wide modelling.

### 8.3.1 Australian Renewable Energy Agency (ARENA) Project

Powerlink received funding from the ARENA to investigate technical, commercial and regulatory solutions to address system strength challenges. The study looks at addressing system strength challenges by exploring the merits of several technical solutions, as well as business and regulatory models to facilitate lower cost solutions and remove commercial barriers. The study is occurring over a number of stages.

For stage 1 Powerlink partnered with GHD to prepare an initial report on system strength. The purpose of the report was to promote better understanding on how system strength can impact investment in generation and transmission network assets. The report targets a broad audience to establish a base level of understanding between all stakeholders involved in the power system and serve as a basis for informing the ongoing development of regulatory frameworks. Solar farm operators Pacific Hydro and Sun Metals also supported the report's development. The 'Managing System Strength during the Transition to Renewables' report was published in May 2020 (refer to Powerlink's website<sup>3</sup>).

<sup>3</sup> Powerlink, [Managing System Strength During the Transition to Renewables, May 2020](#).

## 8 Renewable energy

Subsequent stages of this project build on these foundations. Powerlink will publish a stage 2 report 'PSCAD Assessment of the effectiveness of a centralised synchronous condenser approach' in early November 2020 which demonstrates the potential benefits of connecting proponents sharing a scale-efficient synchronous condenser to meet their individual system strength remediation obligations. This technical viability was demonstrated in a system-wide EMT-type case study, which compared distributed, project specific, synchronous condenser installations to a centralised shared scale-efficient synchronous condenser.

Further stages focus on building understanding of the role 'grid forming' (GFI) inverter technology, can play in contributing to system strength. The aim is to determine whether advanced inverter controls can facilitate a higher penetration of inverter-based renewable generation (e.g. wind and solar) without compromising grid stability.

Initially Powerlink invited inverter manufacturers to test the ability of their product(s) to mitigate system strength challenges. Powerlink provided a simulation test case and defined a range of system and plant conditions and disturbances under which the plant was to be tested for plant stability. For most of the GFI inverters investigated stable operation was simulated down to low Short Circuit Ratios (SCR).

The next step is for Powerlink (in consultation with ARENA and AEMO) to select a promising GFI technology, based on the initial preliminary assessment, and complete a more rigorous system-wide EMT-type analysis. The purpose of this analysis is to evaluate and verify the effectiveness of GFI technology in a 'real world' case and determine their potential to increase the VRE hosting capacity of an area of the Powerlink network. Powerlink anticipate publishing a report on the outcome of this assessment in early 2021.

### 8.3.2 Retuning of transmission connected Static VAR Compensators (SVCs)

Powerlink has redesigned and commissioned changes to the voltage controller at nine SVCs in North and Central Queensland (CQ). In some cases the structure of the voltage control itself was modified to allow the existing plant to support more VRE generation. In other cases, the gain of the voltage controller was changed to minimise the control interactions. These changes have materially increased the renewable energy hosting capacity of the network. This has reduced proponent's connection costs that would have otherwise been required to provide system strength remediation.

### 8.3.3 Inverter level retuning of VRE plant

In late-2019 Powerlink developed a methodology to assess the damping provided by a VRE generator at different oscillation frequencies using an EMT-type model that could be shared with inverter manufactures but still preserve the confidentiality of their propriety information.

This work allowed Powerlink to partner with an inverter manufacturer to investigate changes to the plant voltage control strategy. The outcome of this work recommended that the bandwidth of the voltage control system be higher to counter the 8Hz to 15Hz control interactions that have been observed in Powerlink's network. Powerlink tested this revised control strategy in the state-wide EMT-type model and confirmed its effectiveness.

This approach, initiated by Powerlink in partnership with an inverter manufacturer, has been adopted in the North West Victoria area where five fully commissioned plants were being heavily constrained due to control interactions identified post their commissioning. Powerlink is also leveraging off this development. Powerlink has entered into a contract with Daydream, Hamilton, Hayman and Whitsunday Solar Farms (connected to the Strathmore Substation) to help address the declared fault level shortfall in north Queensland (refer to Section 8.4.1).

## 8.4 Declaration of fault level shortfall

During early 2020, Powerlink and AEMO reviewed the minimum fault level requirements within the Powerlink network. As a result of this review, AEMO published (9 April 2020) a report 'Notice of Queensland System Strength Requirements and Ross Fault Level Shortfall' to the NEM under Clause 5.20C.2(c) of the NER.

The report identified that the fault level nodes for Queensland remain the same as those determined in mid-2018, except for the replacement of the Nebo 275kV node with the Ross 275kV node. The Ross 275kV node is now considered to be a better representation for system strength conditions in north Queensland compared to the Nebo 275kV node.

The minimum three phase fault levels were also determined for all of the Queensland fault level nodes. Powerlink and AEMO carried out detailed EMT-type analysis to determine these system strength requirements for the Queensland region. Using the outcomes from these studies (for example, minimum required synchronous generator combinations), Powerlink and AEMO calculated a new minimum three phase fault level of 1,300MVA at the Ross 275kV fault level node. The updated minimum three phase fault levels for the Queensland fault level nodes are shown in Table 8.1.

**Table 8.1** Three phase fault levels for Queensland fault level nodes

Fault level node	2020 minimum fault level (MVA) (post-contingency)
Gin Gin 275kV	2,250
Greenbank 275kV	3,750
Lilyvale 132kV	1,150
Ross 275kV	1,300
Western Downs 275kV	2,550

Based on the minimum fault level review and assessment of the projected fault levels based on dispatch outcomes from the Draft 2020 Integrated System Plan (ISP) Central scenario market modelling results, AEMO declared an immediate fault level shortfall of 90MVA at the Ross 275kV fault level node. AEMO projected that, if not addressed, this fault level shortfall will continue beyond 2024-25.

Under the NER the responsibility to resolve a fault level shortfall lies with the System Strength Service Provider, which is the TNSP or Jurisdictional Planning Body (JPB) for the region. In Queensland, Powerlink is the System Strength Service Provider which must address these technical issues as efficiently as possible. In accordance with clause 5.20C.2(c) of the NER, AEMO specified 31 August 2021 as the date by which Powerlink should ensure that the necessary system strength services to address the fault level shortfall are available.

#### 8.4.1 Options to address the fault level shortfall

Immediately following the fault level shortfall declaration, Powerlink commenced an Expression of interest (EOI) process for both short and long-term solutions seeking offers for non-network solutions to address the fault level shortfall at Ross. Submissions closed on 13 May 2020 (refer to Section 5.7.1).

Powerlink received a very positive response to the EOI with counter parties offering a range of system strength support services to address the fault level shortfall at Ross and have worked closely with AEMO on the proposed remediation approach.

In the short-term, Powerlink with AEMO's approval, has entered into an agreement with CleanCo Queensland to provide system strength services through utilising its hydro generation assets in FNQ. These short-term support services are in place until 31 December 2020. These services, whilst not fully meeting the fault level shortfall, provide additional hosting capacity. Through the development of system strength constraint advice (refer to Table D.3) the hosting capacity has been determined for various synchronous generator dispatches in Central and NQ. These system strength services from the CleanCo hydro generators, together with the system strength limit equations, reduce the incidence of constraints on the inverter-based generation in NQ.

This partial short-term solution allows Powerlink to continue to work on assessing long-term solutions to address the fault level shortfall. Given the impact of system strength on the hosting capacity in NQ, it is very important for Powerlink to implement additional solutions (or combination of solutions) as soon as possible to minimise the constraints on NQ renewable plants.

## 8 Renewable energy

Offers received as part of the EOI process included inverter tuning to reduce the interactions currently occurring between renewable generation and other control systems, as noted in Section 8.3.3. This included an offer to modify inverters at Daydream, Hamilton, Hayman and Whitsunday Solar Farms connecting to Powerlink's Strathmore Substation. As a result of the modelling by Powerlink, and the subsequent due diligence by AEMO, there is confidence that this inverter retuning will assist with the daytime solution. On this basis Powerlink has entered into an agreement to retune the four plants. These changes are expected to be finalised and commissioned by the end of 2020.

Powerlink will continue to work closely with AEMO to develop more complete and technically feasible short and long-term solutions to the system strength shortfall and undertake the relevant formal approval process in accordance with the NER when the optimal solution has been identified.

### 8.5 Transmission connection and planning arrangements

In May 2017, the AEMC published the Final Determination on the Transmission Connections and Planning Arrangements Rule change request. The Rule sets out significant changes to the arrangements by which parties connect to the transmission network, as well as changes to enhance how transmission network businesses plan their networks.

Since the implementation of the Rule from July 2018, Powerlink has continued to enhance the documentation available and processes used to meet Powerlink's obligations under the NER. Documents updated include the 'Network Configuration Document – Selection for New substations'. Parties seeking connection to Powerlink's network should ensure that they are referencing the most up to date documentation.

During 2018/19, connection activity at both the enquiry and application stages decreased. Powerlink considers that this is not a result of the new connection arrangements, but rather the market reaching a point where the developments already under consideration are focussing on the impact of the Rule changes and the obligations under the Generator Performance Standards (GPS) on their pending investment decisions, and the moderating forward price of electricity and large-scale generation certificates.

Powerlink is focussed on delivering a timely and transparent connection process to connecting generators including coordination of the physical connection works, GPS and system strength.

### 8.6 Indicative available network capacity – Generation Capacity Guide (GCG)

Powerlink provides a significant amount of information for parties seeking connection to the transmission network in Queensland, including the GCG. This guide is designed to provide proponents with an understanding of the current situation in Queensland with regard to system strength and to outline what it means for project planning. Proponents are encouraged to utilise this information to make informed proposals, however we encourage early engagement with Powerlink's Business Development team.

The GCG is published on Powerlink's website separate to the Transmission Annual Planning Report (TAPR) to facilitate updates to the GCG as required to make available the most up to date data for VRE developers. The GCG also includes thermal capacity and congestion information for customers seeking to connect to Powerlink's transmission network.

Under the NEM's open access regime, it is possible for generation to be connected to a connection point in excess of the network's capacity, or for the aggregate generation within a zone to exceed the capacity of the main transmission system. Where this occurs, the dispatch of generation may need to be constrained. This congestion is managed by AEMO in accordance with the procedures and mechanisms of the NEM. It is the responsibility of each generator proponent to assess and consider the consequences of potential congestion, both immediate and into the future.

As outlined in Section 8.4, AEMO declared a fault level shortfall in NQ. While this shortfall indicates the challenges faced for inverter-based connections in this part of the network, it does not mean that new connections are not possible. However, the underlying system strength is now limited throughout the state and there are still a large number of enquiries and applications under consideration. As such, all proponents should consider the strong possibility that system strength support will be required no matter where the project will be located. This support may be provided by a synchronous condenser. However, retuning of the plant's control systems and other technology solutions could be equally effective.

To determine if system strength remediation is required a system-wide EMT-type assessment for a project-specific inverter-based plant must be undertaken. If this assessment identifies an adverse system strength impact then there is an obligation on the VRE proponent to provide system strength remediation. Powerlink will work with the proponent to explore the most cost-effective solution. This may include a shared system strength service.

### 8.6.1 Full Impact Assessment (FIA)

Powerlink now undertakes an FIA for all VRE generation applying to connect to the Powerlink network regardless of the size of the proposed plant and available fault level indicated from the PIA. This is because only an FIA can provide information on the impact of potentially unstable interactions with other generators.

The FIA is carried out as part of the connection process as per AEMO's System Strength Impact Assessment Guidelines. This is to ensure that any adverse system strength impact is adequately identified and addressed as part of the connection application either via a system strength remediation scheme or through system strength connection works.

It is vital that proponents provide high-quality EMT-type models as per AEMO's Power System Model Guidelines<sup>4</sup> for the FIA process. One of the most common delays to project assessments is the need to request changes to proponents' models. Generation must meet the NER GPS, and generation proponents are required to demonstrate that their proposed generation technology is able to meet these standards during the connection process.

AEMO's System Strength Impact Assessment Guidelines<sup>5</sup> provides additional details regarding the assessment process and methodology, while AEMO's Power System Model Guidelines provides additional information regarding modelling requirements.

## 8.7 System strength during network outages

Throughout the year, it is necessary to remove plant in the transmission network from service. In the majority of circumstances planned outages are necessary to maintain or replace equipment. It may also be necessary to remove plant from service unexpectedly. During these planned and unplanned outages, Powerlink and AEMO must ensure that the system continues to be operated in a secure state.

Network outages may lead to reductions in system strength. While this may be a localised issue, outages on key 275kV corridors, as well as some 275/132kV transformers, may impact the system strength of a number of VRE generators. To address this, Powerlink is working with AEMO to develop constraint equations to be implemented in the National Energy Market Dispatch Engine (NEMDE). The purpose of these equations is to maximise the dispatch of VRE generators in the Queensland system within the available system strength.

## 8.8 Transmission congestion and Marginal Loss Factors (MLF)

The location and pattern of generation dispatch influences power flows across most of the Queensland system. Power flows can also vary substantially with planned or unplanned outages of transmission network elements. Power flows may also be higher at times of local area or zone maximum demand or generation, and/or when embedded generation output is lower.

<sup>4</sup> AEMO, [Power System Model Guidelines](#), July 2018.

<sup>5</sup> AEMO, [System Strength Impact Assessment Guidelines](#), July 2018.

## 8 Renewable energy

Maximum power transfer capability may be set by transient stability, voltage stability, thermal plant ratings (transformer and conductor ratings) or protection relay load limits. System strength may also be a constraint that limits the output from large-scale inverter-based generation in an area of the network.

Where constraints occur on the network, AEMO will constrain generation based on the market system rules within NEMDE to maintain system security.

Rapid changes in demand and generation patterns will likely result in transmission constraints emerging over time. Forecasting these constraints is not straightforward as they depend on generation development and bidding patterns in the market. For example, with the existing and committed inverter-based renewable generation in NQ, the utilisation of the Central West to Gladstone and Central to South Queensland grid sections are expected to further increase over time.

Powerlink monitors the potential for congestion to occur and assesses the need for network investments using the Australian Energy Regulator (AER)'s Regulatory Investment Test for Transmission (RIT-T). Where found to be economic, Powerlink will augment the network to ensure the electricity market operates efficiently and at the lowest overall long run cost to consumers.

Generator proponents are encouraged to refer to Chapter 5 and Chapter 7 of Powerlink's TAPR for more detail on potential future network development as well as emerging constraints.

MLFs have also emerged as an important consideration for new entrant generators, especially for photovoltaic (PV) generators in NQ. MLFs adjust the spot price to account for the marginal impact of losses from additional generation. They are calculated as a volume-weighted average for the full year and are determined based on historical generation and demand profiles adjusted for known forward commitments.

In NQ the local supply and demand balance is significant due to the long distances of the transmission system from North to South Queensland. The coincident generation from PVs has resulted in large drops in the MLFs for PV generators in NQ over recent years. The situation is not as significant for wind generators in NQ as a large amount of the wind export is not coincident with the photovoltaic output and hence does not coincide with the large demand and supply imbalance in the region.

MLF reductions across NQ provide an opportunity for additional loads (or storage) to locate in NQ.

### 8.9 Further information

Powerlink will continue to work with market participants and interested parties across the renewables sector to better understand the potential for VRE generation, and to identify opportunities and emerging limitations as they occur. The NER (Clause 5.3) prescribes procedures and processes that NSPs must apply when dealing with connection enquiries. Should an interested party wish to utilise the connection framework referred to in Section 8.4, it will be necessary to submit a new connection enquiry.

**Figure 8.2** Overview of Powerlink's existing network connection process



Proponents who wish to connect to Powerlink's transmission network are encouraged to contact [BusinessDevelopment@powerlink.com.au](mailto:BusinessDevelopment@powerlink.com.au). For further information on Powerlink's network connection process please refer to Powerlink's website.

## **CHAPTER 9**

# Committed, current and recently commissioned network developments

### 9.1 Transmission network



# 9 Committed, current and recently commissioned network developments

## Key highlights

- During 2019/20, Powerlink's efforts have continued to be predominantly directed towards reinvestment in transmission lines and substations across Powerlink's network.
- Powerlink's investment program is focussed on reducing the identified risks arising from assets reaching the end of technical service life and maintaining network resilience while continuing to deliver safe, reliable and cost efficient transmission services to our customers.
- A major project for Powerlink completed since publication of the 2019 Transmission Annual Planning Report (TAPR) has been the rebuild of Dysart Substation which is critical to transporting power to the Dysart township, neighbouring communities, industry and the regional rail network in Central Queensland (CQ).
- While there are no concerns regarding the reliability of power supply, the delivery of Powerlink's regulated program of work, which is currently in progress, has been impacted by the restrictions related to COVID-19.
- Powerlink continues to support the development of all types of energy projects requiring connection to the transmission network in Queensland.

## 9.1 Transmission network

Powerlink Queensland's network traverses 1,700km from north of Cairns to the New South Wales (NSW) border. The Queensland transmission network comprises transmission lines constructed and operated at 330kV, 275kV, 132kV and 110kV. The 275kV transmission network connects Cairns in the north to Mudgeeraba in the south, with 110kV and 132kV systems providing transmission in local zones and providing support to the 275kV network. A 330kV network connects the NSW transmission network to Powerlink's 275kV network at Braemar and Middle Ridge substations.

A geographic representation of Powerlink's transmission network is shown in Figure 9.1.

While there are no concerns regarding the reliability of power supply, there have been impacts on Powerlink's regulated program of work given the restrictions related to COVID-19. The 2020 TAPR provides best information available at the time of publication with regard to the proposed commissioning dates of network reinvestment projects in progress which will be further updated in the 2021 TAPR.

There have been no transmission network developments commissioned or network assets retired<sup>1</sup> since Powerlink's 2019 TAPR was published.

There have been no connection works commissioned since Powerlink's 2019 TAPR was published.

Table 9.1 lists new transmission connection works for supplying loads which are committed and under construction at October 2020. These connection projects resulted from agreement reached with relevant connected customers, generators or Distribution Network Service Providers (DNSPs) as applicable.

Table 9.2 lists network reinvestments commissioned since Powerlink's 2019 TAPR was published.

Table 9.3 lists network reinvestments which are committed at October 2020.

Table 9.4 lists network reinvestments which have recently undergone the Regulatory Investment Test for Transmission (RIT-T) or similar process and are not fully committed at October 2020.

Table 9.5 lists asset retirement works at October 2020.

---

<sup>1</sup> Operational works, such as asset retirements, do not form part of Powerlink's capital expenditure budget.

**Table 9.1** Committed and under construction connection works at October 2020

Project (1)	Purpose	Zone location	Proposed commissioning date
Gangarri Solar Farm	New solar farm	Surat	Quarter 1 2021
Coopers Gap Wind Farm	New wind farm	South West	Quarter 4 2020 (2)

Notes:

- (1) When Powerlink constructs a new line or substation as a non-regulated customer connection (e.g. generator, renewable generator, mine or industrial development), the costs of acquiring easements, constructing and operating the transmission line and/or are paid for by the company making the connection request
- (2) Powerlink's scope of works for this project has been completed. Remaining works associated with generation connection are being coordinated with the customer.

**Table 9.2** Commissioned network reinvestments since June 2019

Project	Purpose	Zone	Date commissioned
Garbutt transformers replacement	Maintain supply reliability in the Ross zone (1)	Ross	July 2019
Line refit works on the 132kV transmission line between Collinsville North and Proserpine substations	Maintain supply reliability to Proserpine	North	July 2020
Dysart Substation replacement	Maintain supply reliability in the Central West zone (1)	Central West	September 2019
Rocklea secondary systems replacement	Maintain supply reliability in the Moreton zone	Moreton	July 2020

Notes:

- (1) Project identified under the RIT-T transitional arrangements in place for committed projects between 18 September 2017 and 30 January 2018.

# 9 Committed, current and recently commissioned network developments

**Table 9.3** Committed network reinvestments at October 2020

Project	Purpose	Zone	Proposed commissioning date
Woree secondary systems replacement	Maintain supply reliability in the Far North zone (1)	Far North	December 2022
Woree SVC secondary systems replacement	Maintain supply reliability in the Far North zone (1)	Far North	December 2022
Kamerunga 132kV Substation replacement	Maintain supply reliability in the Far North zone (1)	Far North	December 2024
Ingham South 132/66kV transformers replacement	Maintain supply reliability in the Ross zone (1)	Ross	August 2021
Line refit works on the 132kV transmission line between Townsville South and Clare South substations	Maintain supply reliability in the Ross zone (1)	Ross	December 2021
Townsville South 132kV primary plant replacement	Maintain supply reliability in the Ross zone (1)	Ross	October 2022
Ross 132kV primary plant replacement	Maintain supply reliability in the Ross zone (1)	Ross	October 2024
Ross 275kV primary plant replacement	Maintain supply reliability in the Ross zone (1)	Ross	October 2024
Kemmis 132/66kV transformer replacement	Maintain supply reliability in the North zone	North	November 2020
Line refit works on the 132kV transmission line between Eton tee and Alligator Creek Substation	Maintain supply reliability in the North zone (2)	North	October 2021
Mackay Substation replacement	Maintain supply reliability in the North zone (6)	North	December 2021
Strathmore 275/132kV transformer establishment	Maintain supply reliability in the North zone (1)	North	December 2021
Nebo primary plant and secondary systems replacement	Maintain supply reliability in the North zone (6)	North	August 2022
Kemmis 132kV secondary systems replacement	Maintain supply reliability in the North zone	North	June 2023
Line refit works on the 132kV transmission line between Egans Hill and Rockhampton Substation	Maintain supply reliability in the Central West zone (1)(6)	Central West	December 2020
Lilyvale 132/66kV transformers replacement	Maintain supply reliability in the Central West zone (6)	Central West	June 2021
Calvale and Callide B secondary systems replacement	Maintain supply reliability in the Central West zone (2)(5)(6)	Central West	June 2021
Calvale 275/132kV transformer reinvestment	Maintain supply reliability in the Central West zone (2)(4)(6)	Central West	June 2021
Moura Substation replacement	Maintain supply reliability in the Central West zone (3)	Central West	December 2021

**Table 9.3** Committed network reinvestments at October 2020 (continued)

Project	Purpose	Zone	Proposed commissioning date
Bouldercombe transformer replacement	Maintain supply reliability in the Central West zone (1)	Central West	December 2021
Blackwater 66kV CT & VT replacement	Maintain supply reliability in the Central West zone	Central West	June 2022
Blackwater 132kV transformers replacement	Maintain supply reliability in the Central West zone	Central West	June 2022
Dysart transformer replacement	Maintain supply reliability in the Central West zone (2)	Central West	June 2022
Lilyvale 132/275kV primary plant replacement	Maintain supply reliability in the Central West zone (6)	Central West	October 2022
Bouldercombe primary plant replacement	Maintain supply reliability in the Central West zone (1)	Central West	June 2023
Baralaba secondary systems replacement	Maintain supply reliability in the Central West zone (1)	Central West	December 2023
Wurdong secondary systems replacement	Maintain supply reliability in the Gladstone zone	Gladstone	October 2021
Boyne Island secondary systems replacement	Maintain supply reliability in the Gladstone zone	Gladstone	December 2021
Line refit works on 275kV transmission line between Woolooga and Palmwoods	Maintain supply reliability in the Wide Bay zone (2)	Wide Bay	June 2021
Gin Gin Substation rebuild	Maintain supply reliability in the Wide Bay zone (2)	Wide Bay	December 2021
Tarong secondary systems replacement	Maintain supply reliability in the South West zone (1)(6)	South West	June 2022
Ashgrove West Substation replacement	Maintain supply reliability in the Moreton zone (2)(6)	Moreton	July 2021
Belmont 275kV secondary systems replacement	Maintain supply reliability in the Moreton zone (1)(6)	Moreton	June 2021
Abermain 110kV secondary systems replacement	Maintain supply reliability in the Moreton zone (1)(6)	Moreton	June 2021
Palmwoods 275kV secondary systems replacement	Maintain supply reliability in the Moreton zone (1)(6)	Moreton	July 2021
Line refit works on the 110kV transmission lines between South Pine and Upper Kedron	Maintain supply reliability in the Moreton zone (1)	Moreton	November 2021
Line refit works on the 110kV transmission lines between West Darra and Sumner	Maintain supply reliability in the Moreton zone (1)	Moreton	November 2021
Line refit works on the 110kV transmission lines between Rocklea and Sumner	Maintain supply reliability in the Moreton zone (1)	Moreton	November 2021
Mudgeeraba 275kV secondary systems replacement	Maintain supply reliability in the Gold Coast zone (1)	Gold Coast	December 2021

## 9 Committed, current and recently commissioned network developments

### Notes:

- (1) RIT-T project undertaken after the commencement of the Replacement expenditure planning arrangements Rule 2017 No.5.
- (2) Project identified under the RIT-T transitional arrangements in place for committed projects between 18 September 2017 and 30 January 2018.
- (3) Major works were completed in October 2017. Minor works scheduling is being coordinated with Ergon Energy (Energex and Ergon Energy are part of the Energy Queensland Group).
- (4) Approved works were rescope as part of the Callide A/Calvale 132kV transmission reinvestment, previously named Callide A Substation replacement. Refer to Section 5.7.5.
- (5) The majority of Powerlink's staged works are anticipated for completion by summer 2020/21. Remaining works associated with generation connection will be coordinated with the customer.
- (6) Projects impacted by restrictions related to COVID-19.

**Table 9.4** Uncommitted network reinvestments at October 2020

Project	Purpose	Zone	Proposed commissioning date
Cairns secondary systems replacement	Maintain supply reliability in the Far North zone	Far North	December 2024
Gladstone South secondary systems replacement	Maintain supply reliability in the Gladstone zone	Gladstone	April 2024
QAL West secondary systems replacement	Maintain supply reliability in the Gladstone zone	Gladstone	April 2024
Mt England 275kV secondary systems replacement	Maintain supply reliability in the Moreton zone	Moreton	October 2023

**Table 9.5** Asset retirement works at October 2020 (I)

Project	Purpose	Zone	Proposed retirement date
132kV transmission line retirement between Townsville South and Clare South substations	Removal of assets at the end of technical life in the North zone	North	December 2022
Mudgeeraba No 3 275/110kV transformer retirement	Removal of asset at the end of technical life in the Gold Coast zone	Gold Coast	June 2022

Note:

(I) Operational works, such as asset retirements, do not form part of Powerlink's capital expenditure budget.

# 9 Committed, current and recently commissioned network developments

Figure 9.1 Existing Powerlink Queensland transmission network October 2020



# Appendices

- Appendix A Forecast of connection point maximum demands
- Appendix B TAPR templates
- Appendix C Zone and grid section definitions
- Appendix D Limit equations
- Appendix E Indicative short circuit currents
- Appendix F Compendium of potential non-network solution opportunities within the next five years
- Appendix G Glossary



## Appendix A Forecast of connection point maximum demands

Appendix A addresses National Electricity Rules (NER) (Clause 5.12.2(c)(1))<sup>1</sup> which requires the Transmission Annual Planning Report (TAPR) to provide 'the forecast loads submitted by a Distribution Network Service Provider (DNSP) in accordance with Clause 5.11.1 or as modified in accordance with Clause 5.11.1(d)'. This requirement is discussed below and includes a description of:

- the forecasting methodology, sources of input information and assumptions applied (Clause 5.12.2(c)(i)) (refer to Section A.1)
- a description of high, most likely and low growth scenarios (refer to Section A.2)
- an analysis and explanation of any aspects of forecast loads provided in the TAPR that have changed significantly from forecasts provided in the TAPR from the previous year (refer to Section A.3).

### A.1 Forecasting methodology used by Energex and Ergon Energy (part of the Energy Queensland Group) for maximum demand

Energex and Ergon Energy review and update the 10-year 50% Probability of Exceedance (PoE) and 10% PoE system summer maximum demand forecasts after each summer season. Each new forecast is used to identify emerging network limitations in the sub-transmission and distribution networks. For consistency, the Energex and Ergon Energy's forecast system level maximum demand is reconciled with the bottom-up substation maximum demand forecast after allowances for network losses and diversity of maximum demands.

Distribution forecasts are developed using data from Australian Bureau of Statistics (ABS), the Queensland Government, the Australian Energy Market Operator (AEMO), internally sourced rooftop photovoltaic (PV) connections and historical maximum demand data. Forecasts from the National Institute of Economic and Industry Research (NIEIR) and Deloitte Access Economics are also utilised.

The methodology used to develop the system demand forecast as recommended by consultants ACIL Tasman, is as follows:

#### *Ergon*

- Develop a six region based forecast within the Ergon network, with the aggregation at the distribution system peak time to provide a system peak 50% PoE. Each regional forecast uses a multiple regression equation to determine the relationship between demand and Gross State Product (GSP), maximum temperature, minimum temperature, total electricity price, a structural break, three continuous hot days, weekends, Fridays and the Christmas period. The summer regression uses data from November to March with days which fall below 28.5°C excluded from the analysis.
- A Monte-Carlo process is used across the South East Queensland (SEQ) and regional models to simulate a distribution of summer maximum demands using the latest 20 years of summer temperatures and an independent 10-year gross GSP forecast.
- Using the 30 top summer maximum demands from the simulation, produce a probability distribution of maximum demands to identify the 50% PoE and 10% PoE maximum demands.
- A stochastic term is applied to the simulated demands based on a random normal distribution of the multiple regression standard error. This process attempts to define the maximum demand rather than the regression average demand.
- Modify the calculated system maximum demand forecasts by the reduction achieved through the application of demand management initiatives. An adjustment is also made in the forecast for the expected impact of rooftop PV, battery storage and electric vehicles (EV) based on the maximum demand daily load profile and anticipated usage patterns.

---

<sup>1</sup> Where applicable, Clauses 5.12.2(c)(iii) and (iv) are discussed in Chapter 2.

**Energex**

- Uses a multiple regression equation for the relationship between demand and GSP, square of weighted maximum temperature, weighted minimum temperature, total electricity price, structural break, three continuous hot days, weekends, Fridays and the Christmas period. The summer regression uses data from November to March, with the temperature data excluding days where the weather station's temperatures are below set levels (for example, Amberley mean temperatures < 22.7°C and daily maximum temperature < 30°C). Three weather stations are incorporated into the model via a weighting system to capture the influence of the sea breeze on peak demand. Statistical testing is applied to the model before its application to ensure that there is minimal bias in the model.
- A Monte-Carlo process is used to simulate a distribution of summer maximum demands using the latest 30 years of summer temperatures and an independent ten-year GSP forecast.
- Using the 30 top summer maximum demands, produce a probability distribution of maximum demands to identify the 50% PoE and 10% PoE maximum demands.
- A stochastic term is applied to the simulated demands based on a random distribution of the multiple regression standard error. This process attempts to define the maximum demand rather than the regression average demand.
- Modify the calculated system maximum demand forecasts by the reduction achieved through the application of demand management initiatives. An adjustment is also made in the forecast for rooftop PV, battery storage and the expected impact of EV based on the maximum demand daily load profile and anticipated usage patterns.

**A.2 Description of Energex's and Ergon Energy's high, medium and low growth scenarios for maximum demand**

The scenarios developed for the high, medium and low case maximum demand forecasts were prepared in June 2020 based on the latest information. The 50% PoE and 10% PoE maximum demand forecasts sent to Powerlink in June 2020 are based on these assumptions. In the forecasting methodology high, medium and low scenarios refer to maximum demand rather than the underlying drivers or independent variables. This avoids the ambiguity on both high and low meaning, as there are negative relationships between the maximum demand and some of the drivers e.g. high demand normally corresponds to low battery installations.

**Block Loads**

There are many block loads scheduled over the next 11 years. For the majority, the block loads are incorporated at the relevant level of the network e.g. zone substation. Only a small number are considered large enough to justify accounting for them at the system level models. Ergon does not currently incorporate any block loads in the system level models. Energex has between 20MW and 50MW of block loads incorporated in the system model over the forecast horizon.

At the zone substation level, Energy Queensland is currently tracking around 40MW of block loads for Ergon, and 70 MW for Energex. However, only the block loads which have a significant influence on the zone substation's peak demand are incorporated.

**Summary of the Energex model**

The latest system demand model for the South-East Queensland region incorporates economic, temperature and customer behavioural parameters in a multiple regression as follows:

- Demand MW = function of (weekend, Christmas, Friday, square of weighted maximum temperature, weighted minimum temperature, humidity index, total price, Queensland GSP, structural break, three continuous hot days, and a constant).
- In particular, the total price component incorporated into the latest model aims to capture the response of customers to the changing price of electricity. The impact of price is based on the medium scenarios for the Queensland residential price index forecast prepared by NIEIR in their System Maximum Demand Forecasts.

## **Energex high growth scenario assumptions for maximum demand**

- GSP – The 'high' case of GSP growth (3.3% per annum, not COVID-19 adjusted).
- Total real electricity price – Affects MW demand negatively, so the 'low' case of annual price changes is assumed to be 1% lower than the base case (compounded and Consumer Price Index (CPI) adjusted).
- Queensland population – The same start value as the base case in 2020, then follow the down-up trend before stabilising at around 1.8% by 2031.
- Rooftop PV – Lack of incentives for customers who lost the feed-in tariff (FIT) tariffs, plus slow falls in battery prices which discourage PV installations. Capacity may reach 3,159 MW by 2031.
- Battery storage – Prices fall slowly, battery safety remains an issue, and kW demand based network tariff is not introduced. Peak time (negative) contribution will reach 79 MW by 2031.
- EV – Significant fall in EV prices, accessible and fast charging stations, enhanced features, a variety of types, plus escalated petrol prices. The peak time contribution (without diversity ratio adjusted) may reach 233 MW by 2031.
- Weather – follow the recent 30-year trend.

## **Energex medium growth scenario assumptions for maximum demand**

- GSP – The medium case of GSP growth (2.2% per annum over the next 11 years – not COVID-19 adjusted).
- Total real electricity price – The medium case of annual price change of 0.6%.
- Queensland population – Grew 1.7% in 2019, and is expected to maintain at 1.5% in 2020 (partially affected by the COVID-19 pandemic), down to 0.6% (COVID-19 adjusted), before bouncing back to 1.2% in 2021, and gradually stabilising at around 1.4% by 2031 (based on the Deloitte's April 2020 forecasts).
- Rooftop PV – Inverter capacity will increase from 1,959 MW (February 2020) to 3,667 MW (February 2031);
- Battery storage – Peak time (negative) contribution will have a slow start of around 4 MW in 2020, but will gradually accelerate to 182 MW by 2031.
- EV – Stagnant in the short-term, boom in the long-term. Peak time contribution will only amount to 1.0 MW in 2020, but will reach 195 MW by 2031. Note however, EV will also have a significant impact on GWh energy sales.
- Weather – follow the recent 30-year trend.

## **Energex low growth scenario assumptions for maximum demand**

- GSP – The 'low' case GSP growth (1.3% per annum, not COVID-19 adjusted).
- Total real electricity price – The 'high' case of annual price changes is assumed to be 1% higher than the base case (compounded and CPI adjusted) values.
- Queensland population – The same start value as the base case in 2020, weak GDP growth plus loss in productivity may slow population growth to 1.0% by 2031.
- Solar PV – Strong incentives for customers who lost the FIT tariffs, plus fast falls in battery prices encourage more PV installations. Capacity may reach 4,183 MW by 2031.
- Battery storage – Prices fall quickly, no battery safety issues, and kW demand based network tariff is introduced. Peak time (negative) contribution may reach a high at 308 MW by 2031.
- EV – Slow fall in EV prices, hard to find charging stations, charging time remaining long, still having basic features, less type sections, plus cheap petrol prices. The peak time contribution (without diversity ratio adjusted) may settle at 110 MW by 2031.
- Weather – follow the recent 30-year trend.

## **Summary of the Ergon Energy model**

The system demand model for regional Queensland incorporates economic, temperature and customer behavioural parameters in a multiple regression as follows:

- Aggregation of six regional forecasts to provide a system peak 50PoE at network peak coincidence.
- Demand MW = function of (weekend, public holidays, regional maximum temperature, Queensland GSP, structural break, demand management terms, and a constant).
- The demand management term captures historical movements of customer responses to the combination of PV uptake, tariff price changes and customer appliance efficiencies.

#### Ergon Energy's high growth scenario assumptions for maximum demand

- GSP – the high case of GSP growth (adjusted to 3.3% per annum over the next 11 years).  
Queensland population – growth of 0.6% pa to 2021, progressively increasing to 1.2% in 2021 and maintaining a level of approximately 1.5% by 2030.
- Rooftop PV – numbers and capacity monitored and estimated.
- Battery storage – numbers and capacity monitored and estimated.
- EV – numbers and capacity monitored and estimated.
- Weather – follow the recent trend of 20 years.

#### Ergon Energy's medium growth scenario assumptions for maximum demand

- GSP – the 'medium' case of GSP growth (adjusted to 2.2% per annum over the next 11 years).

#### Ergon Energy's low growth scenario assumptions for maximum demand

- GSP – the 'low' growth case of GSP growth (adjusted to 1.3% per annum over the next 11 years).

### A.3 Significant changes to the connection point maximum demand forecasts

Major differences between the 2020 forecast and the 2019 forecast can generally be attributed to natural variation in peaks below the connection point level, which can result in displaying an associated variation in year on year changes at the connection point level, and with changes in the growth in the lower levels of the network rather than from any network configuration changes or significant block loads. The forecast uptake of EV has increased especially in the second half of the 2020 forecast when compared to the 2019 forecast. This, combined with yearly load variations affecting the start values are the major cause of the differences observed between the two forecasts.

Energex connection points with the greatest difference in growth between the 2020 and 2019 forecasts are:

Connection Point	Change in growth rate
Blackstone 110kV	1.3% pa
Goodna 33kV	1.1% pa
Abermain 110kV	1.0% pa
Ashgrove West 110kV	-1.1% pa

Ergon connection points with the greatest difference in growth between the 2020 and 2019 forecasts are:

Connection Point	Change in growth rate
Moranbah 132kV	3.2% pa
Moranbah 66kV	1.5% pa
Newlands 66kV	-1.1% pa
Tangkam 110kV	-1.7% pa
Ross (Kidston and Millchester) 132kV	-2.7% pa

## A.4 Customer forecasts of connection point maximum demands

Tables A.1 to A.18 which are available on [Powerlink's website](#), show 10-year forecasts of native summer and winter demand at connection point peak, for high, medium and low growth scenarios (refer to Appendix A.2). These forecasts have been supplied by Powerlink customers.

The connection point reactive power (MVar) forecast includes the customer's downstream capacitive compensation.

Groupings of some connection points are used to protect the confidentiality of specific customer loads.

In tables A.1 to A.18 the zones in which connection points are located are abbreviated as follows:

FN	Far North zone
R	Ross zone
N	North zone
CW	Central West zone
G	Gladstone zone
WB	Wide Bay zone
S	Surat zone
B	Bulli zone
SW	South West zone
M	Moreton zone
GC	Gold Coast zone

## Appendix B TAPR templates

In accordance with Clause 5.14B.1(a) of the National Electricity Rules (NER), the Australian Energy Regulator (AER)'s TAPR Guidelines<sup>1</sup> set out the required format of TAPRs, in particular the provision of TAPR templates to complement the TAPR document. The purpose of the TAPR templates is to provide a set of consistent data across the National Electricity Market (NEM) to assist stakeholders to make informed decisions.

Readers should note the data provided is not intended to be relied upon explicitly for the evaluation of investment decisions. Interested parties are encouraged to contact Powerlink in the first instance.

The TAPR templates may be directly accessed on [Powerlink's website](#)<sup>2</sup>. Alternatively please contact [NetworkAssessments@powerlink.com.au](mailto:NetworkAssessments@powerlink.com.au) for assistance.

For consistency with the TAPR document, the TAPR templates are able to filtered by Powerlink's geographical zones and outlook period, as well as the AER TAPR Guidelines template type (transmission connection point / line segment / new generator connection).

### Context

While care is taken in the preparation of TAPR templates, data is provided in good faith, Powerlink Queensland accepts no responsibility or liability for any loss or damage that may be incurred by persons acting in reliance on this information or assumptions drawn from it.

The proposed preferred investment and associated data is indicative, has the potential to change and will be economically assessed under the Regulatory Investment Test for Transmission (RIT-T) consultation process as/if required at the appropriate time. TAPR templates may be updated at the time of RIT-T commencement to reflect the most recent data and to better inform non-network providers<sup>3</sup>. Changes may also be driven by the external environment, advances in technology, non-network solutions and outcomes of other RIT-T consultations which have the potential to shape the way in which the transmission network develops.

There is likely to be more certainty in the need to reinvest in key areas of the transmission network which have been identified in the TAPR in the near term, as assets approach their anticipated end of technical service life. However, the potential preferred investments (and alternative options) identified in the TAPR templates undergo detailed planning to confirm alignment with future reinvestment, optimisation and delivery strategies. This near-term analysis provides Powerlink with an additional opportunity to deliver greater benefits to customers through improving and further refining options. In the medium to long-term, there is less certainty regarding the needs or drivers for reinvestments. As a result, considerations in the latter period of the annual planning review require more flexibility and have a greater potential to change in order to adapt to the external environment as the NEM evolves and customer behaviour changes.

Where an investment is primarily focussed on addressing asset condition issues, Powerlink has not attempted to quantify the impact on the market e.g. where there are market constraints arising from reconfiguration of the network around the investment and Powerlink considers that generation operating within the market can address this constraint.

Groupings of some connection points are used to protect the confidentiality of specific customer loads.

### Methodology/principles applied

The AER's TAPR Guidelines incorporate text to define or explain the different data fields in the template. Powerlink has used these definitions in the preparation of the data within the templates. Further to the AER's data field definitions, Powerlink provides details on the methodology used to forecast the daily demand profiles. Table B.1 also provides further context for some specific data fields.

The data fields are denoted by their respective AER Rule designation, TGCPXXX (TAPR Guideline Connection Point) and TGTLXXX (TAPR Guideline Transmission Line).

---

<sup>1</sup> First published in December 2018.

<sup>2</sup> Refer to the Resources tab on the [TAPR website page](#).

<sup>3</sup> Separate to the publication of the TAPR document which occurs annually.

## Development of daily demand profiles

Forecasts of the daily demand profiles for the days of annual maximum and minimum demands over the next 10 years were developed using an in-house tool. These daily demand profiles are an estimate and should only be used as a guide. The 10-year forecasts of daily demand profiles that have been developed for the TAPR templates include:

- 50% PoE maximum demand, MVA<sup>4</sup> (TGCP008)
- Minimum demand, MVA<sup>4</sup> (TGCP008)
- 50% PoE Maximum demand, MW (TGCP010)
- Minimum demand, MW (TGCP011)

Powerlink's in-house load profiling tool, incorporates a base year (1 October 2018 to 1 October 2019) of historical demand and weather data (temperature and solar irradiance) for all loads supplied from the Queensland transmission network. The tool then adds at the connection point level the impacts of future forecasts of roof-top photovoltaic (PV), distribution connected PV solar farms, battery storage, EV and load growth.

The maximum demand of every connection point within the base year has been scaled to the medium growth 50% PoE maximum demand connection point forecasts, as supplied by Powerlink's customers post-winter 2019 (the previous revision of those listed in Appendix A).

As Powerlink does not receive a minimum demand connection point forecast from its customers, the minimum demand is not scaled. The minimum demand is determined by the base year's half hour demands and the impacts of roof-top PV, distribution connected PV solar farms, battery storage and EV.

The maximum demand forecast on the minimum demand day (TGCP009) and the forecast daily demand profile on the minimum demand day (TGCP011) were determined from the minimum (annual) daily demand profiles.

---

<sup>4</sup> Where the MW transfer through the asset with emerging limitations reverses in direction, the MVA is denoted a negative value.

**Table B.1** Further definitions for specific data fields

Data field	Definition
TGCP013 and TGTL008 Maximum load at risk per year	Forecast maximum load at risk is the raw data and does not reflect the requirements of Powerlink's jurisdictional planning standard used to calculate non-network solution requirements. Please refer to Chapter 5 and/or Appendix F for information.
TGCP016 and TGTL011 Preferred investment - capital cost	The timing reflected for the estimated capital cost is the year of proposed project commissioning. RIT-Ts to identify the preferred option for implementation would typically commence three to five years prior to this date, relative to the complexity of the identified need, option analysis required and consideration of the necessary delivery timeframes to enable the identified need to be met. To assist non-network providers, RIT-Ts in the nearer term are identified in Table 5.4.
TGCP017 and TGTL012 Preferred investment - Annual operating cost	Powerlink has applied a standard 2% of the preferred investment capital cost to calculate indicative annual operating costs.
TGCP024 Historical connection point rating	Includes the summer and winter ratings for the past three years at the connection point. The historical connection point rating is based on the most limiting network component on Powerlink's network, in transferring power to a connection point. However lower downstream distribution connection point ratings could be more limiting than the connection point ratings on Powerlink's network.
TGCP026 Unplanned outages	Unplanned outage data relates to Powerlink's transmission network assets only. Forced and faulted outages are included in the data provided. Information provided is based on calendar years from January 2017 to December 2019.
TGPC028 and TGTL019 Annual economic cost of constraint	The annual economic cost of the constraint is the direct product of the annual expected unserved energy and the Value of Customer Reliability (VCR) related to the investment. It does not consider cost of safety risk or market impacts such as changes in the wholesale electricity cost or network losses.
TGTL005 Forecast 10-year asset rating	Asset rating is based on an enduring need for the asset's functionality and is assumed to be constant for the 10-year outlook period.
TGTL017 Historical line load trace	Due to the meshed nature of the transmission network and associated power transfers, the identification of load switching would be labour intensive and the results inconclusive. Therefore the data provided does not highlight load switching events.



## Appendix C Zone and grid section definitions

This appendix provides definitions of illustrations of the 11 geographical zones and eight grid sections referenced in this Transmission Annual Planning Report (TAPR).

Tables C.1 and C.2 provide detailed definitions of zone and grid sections.

Figures C.1 and C.2 provide illustrations of the generation, load and grid section definitions.

**Table C.1** Zone definitions

Zone	Area covered
Far North	North of Tully, including Chalumbin
Ross	North of King Creek and Bowen North, excluding the Far North zone
North	North of Broadsound and Dysart, excluding the Far North and Ross zones
Central West	South of Nebo, Peak Downs and Mt McLaren, and north of Gin Gin, but excluding the Gladstone zone
Gladstone	South of Raglan, north of Gin Gin and east of Calvale
Wide Bay	Gin Gin, Teebar Creek and Woolooga 275kV substation loads, excluding Gympie
Surat	West of Western Downs and south of Moura, excluding the Bulli zone
Bulli	Goondiwindi (Waggamba) load and the 275/330kV network south of Kogan Creek and west of Millmerran
South West	Tarong and Middle Ridge load areas west of Postmans Ridge, excluding the Bulli zone
Moreton	South of Woolooga and east of Middle Ridge, but excluding the Gold Coast zone
Gold Coast	East of Greenbank, south of Coomera to the Queensland/New South Wales border

**Table C.2** Grid section definitions (1)

Grid section	Definition
FNQ	Ross into Chalumbin 275kV (2 circuits) Tully into Woree 132kV (1 circuit) Tully into El Arish 132kV (1 circuit)
CQ-NQ	Bouldercombe into Nebo 275kV (1 circuit) Broadsound into Nebo 275kV (3 circuits) Dysart to Peak Downs 132kV (1 circuit) Dysart to Eagle Downs 132kV (1 circuit)
Gladstone	Bouldercombe into Calliope River 275kV (1 circuit) Raglan into Larcom Creek 275kV (1 circuit) Calvale into Wurdong 275kV (1 circuit) Callide A into Gladstone South 132kV (2 circuits)
CQ-SQ	Wurdong to Teebar Creek 275kV (1 circuit) (2) Calliope River to Gin Gin/Woolooga 275kV (2 circuits) Calvale into Halys 275kV (2 circuits)
Surat	Western Downs to Columboola 275kV (1 circuit) Western Downs to Orana 275kV (1 circuit) Tarong into Chinchilla 132kV (2 circuits)
SWQ	Western Downs to Halys 275kV (1 circuit) Western Downs to Coopers Gap 275kV (1 circuit) Braemar (East) to Halys 275kV (2 circuits) Millmerran to Middle Ridge 330kV (2 circuits)
Tarong	Tarong to South Pine 275kV (1 circuit) Tarong to Mt England 275kV (2 circuits) Tarong to Blackwall 275kV (2 circuits) Middle Ridge to Greenbank 275kV (2 circuits)
Gold Coast	Greenbank into Mudgeeraba 275kV (2 circuits) Greenbank into Molendinar 275kV (2 circuits) Coomera into Cades County 110kV (1 circuit)

Notes:

- (1) The grid sections defined are as illustrated in Figure C.2. X into Y – the MW flow between X and Y measured at the Y end; X to Y – the MW flow between X and Y measured at the X end.
- (2) CQ-SQ cutset redefined following Rodds Bay Solar Farm connection in winter 2022. Wurdong to Teebar Creek 275kV becomes Rodds Bay to Teebar Creek 275kV.

Figure C.1 Generation and load legend

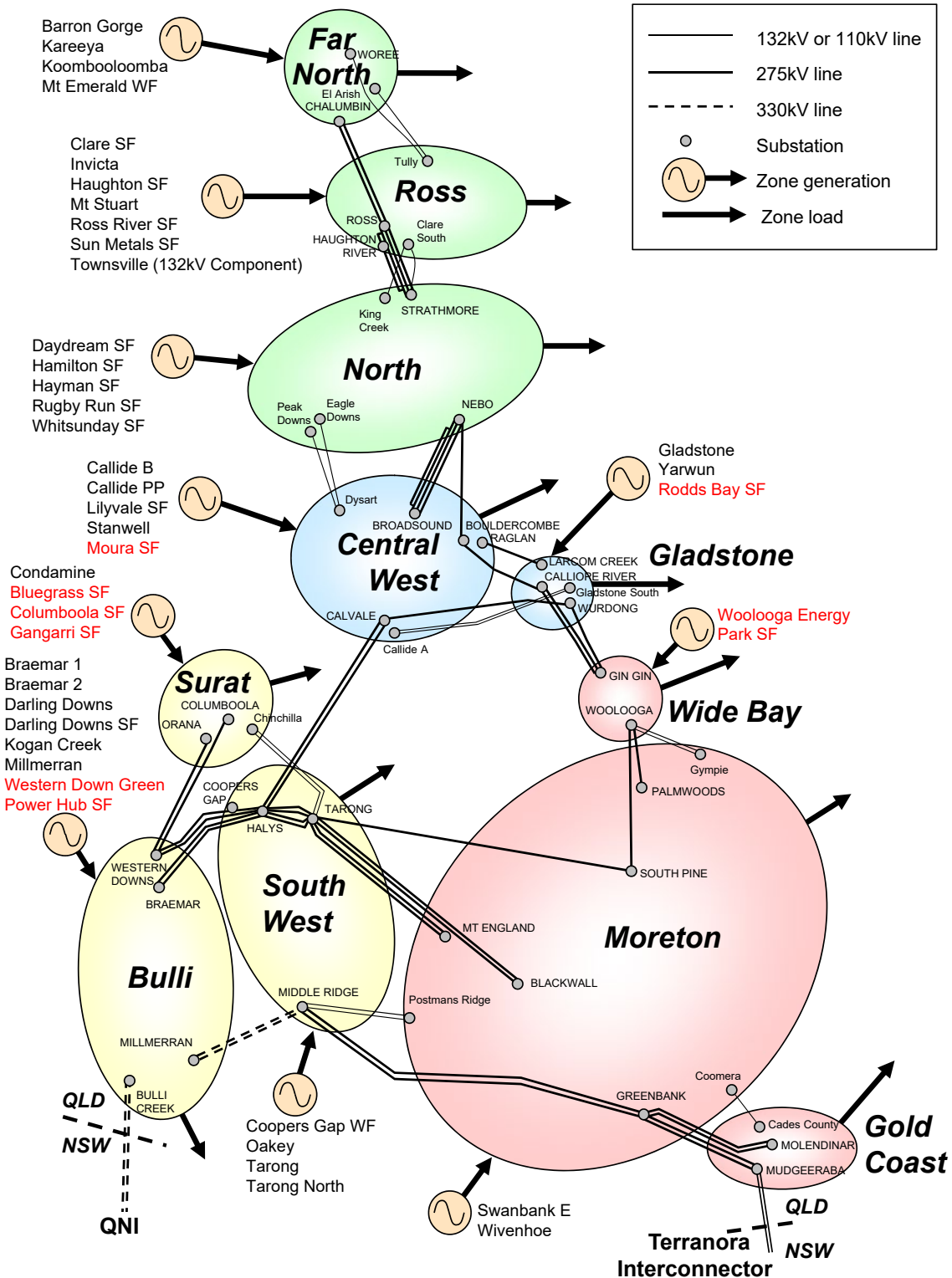
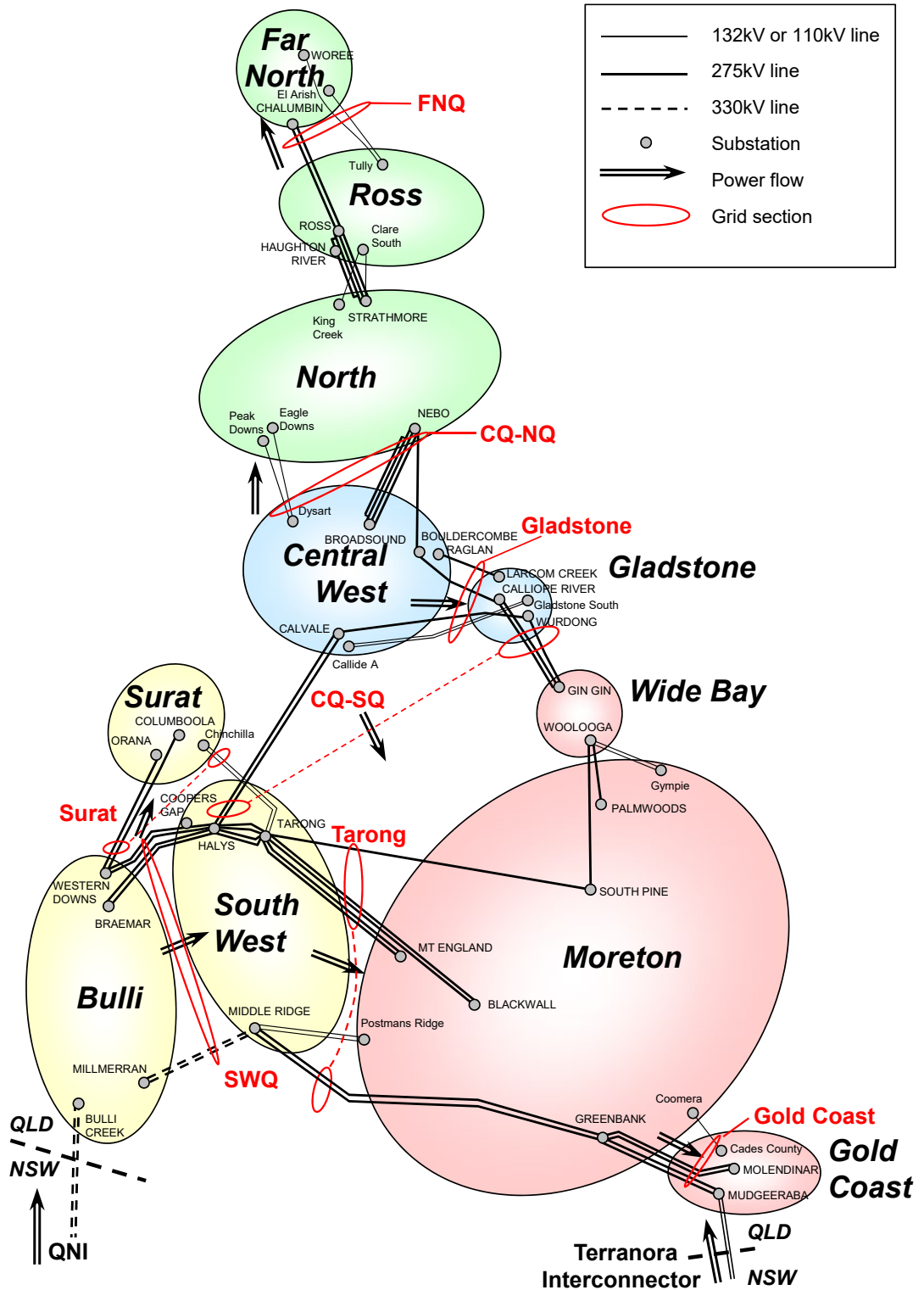

Figure C.2 Grid section legend



## Appendix D Limit equations

This appendix lists the Queensland intra-regional limit equations, derived by Powerlink, valid at the time of publication. The AEMO defines other limit equations for the Queensland Region in its market dispatch systems. It should be noted that these equations are continually under review to take into account changing market and network conditions.

Please contact Powerlink to confirm the latest form of the relevant limit equation if required.

**Table D.1** Far North Queensland (FNQ) grid section voltage stability equation

Measured variable	Coefficient
Constant term (intercept)	-19.00
FNQ demand percentage (1) (2)	17.00
Total MW generation at Barron Gorge, Kareeya and Koombooloomba	-0.46
Total MW generation at Mt Stuart and Townsville	0.13
Total MW generation at Mt Emerald	-1.00
AEMO Constraint ID	Q^NIL_FNQ

Notes:

- (1) FNQ demand percentage =  $\frac{\text{Far North zone demand}}{\text{North Queensland area demand}} \times 100$
- Far North zone demand (MW) = FNQ grid section transfer + (Barron Gorge + Kareeya + Mt Emerald Wind Farm) generation
- NQ area demand (MW) = CQ-NQ grid section transfer + (Barron Gorge + Kareeya + Koombooloomba + Mt Emerald Wind Farm + Townsville + Ross River Solar Farm + Haughton Solar Farm + Pioneer Mill + Mt Stuart + Sun Metals Solar Farm + Kidston Solar Farm + Kennedy Energy Park + Invicta Mill + Clare Solar Farm + Collinsville Solar Farm + Whitsunday Solar Farm + Hamilton Solar Farm + Hayman Solar Farm + Daydream Solar Farm + Mackay + Racecourse Mill + Moranbah + Moranbah North + Rugby Run Solar Farm) generation

(2) The FNQ demand percentage is bound between 22 and 31.

**Table D.2** Central to NQ grid section voltage stability equations

Measured variable	Coefficient	
	Equation 1 Feeder contingency	Equation 2 Townsville contingency (I)
Constant term (intercept)	1,500	1,650
Total MW generation at Barron Gorge, Kareeya and Koombooloomba	0.321	–
Total MW generation at Townsville	0.172	-1.000
Total MW generation at Mt Stuart	-0.092	-0.136
Number of Mt Stuart units on line [0 to 3]	22.447	14.513
Total MW generation at Mackay	-0.700	-0.478
Total MW northern VRE (2)	-1.00	-1.00
Total nominal MVAR shunt capacitors on line within nominated Ross area locations (3)	0.453	0.440
Total nominal MVAR shunt reactors on line within nominated Ross area locations (4)	-0.453	-0.440
Total nominal MVAR shunt capacitors on line within nominated Strathmore area locations (5)	0.388	0.431
Total nominal MVAR shunt reactors on line within nominated Strathmore area locations (6)	-0.388	-0.431
Total nominal MVAR shunt capacitors on line within nominated Nebo area locations (7)	0.296	0.470
Total nominal MVAR shunt reactors on line within nominated Nebo area locations (8)	-0.296	-0.470
Total nominal MVAR shunt capacitors available to the Nebo Q optimiser (9)	0.296	0.470
Total nominal MVAR shunt capacitors on line not available to the Nebo Q optimiser (9)	0.296	0.470
AEMO Constraint ID	Q^NIL_CN_ FDR	Q^NIL_CN_ GT

# Appendices

## Notes:

- (1) This limit is applicable only if Townsville Power Station is generating.
- (2) Northern VRE include:
  - Mt Emerald Wind Farm
  - Ross River Solar Farm
  - Sun Metals Solar Farm
  - Haughton Solar Farm
  - Clare Solar Farm
  - Kidston Solar Farm
  - Kennedy Energy Park
  - Collinsville Solar Farm
  - Whitsunday Solar Farm
  - Hamilton Solar Farm
  - Hayman Solar Farm
  - Daydream Solar Farm
  - Rugby Run Solar Farm
- (3) The shunt capacitor bank locations, nominal sizes and quantities for the Ross area comprise the following:

Ross 132kV	1 × 50MVA <sub>r</sub>
Townsville South 132kV	2 × 50MVA <sub>r</sub>
Dan Gleeson 66kV	2 × 24MVA <sub>r</sub>
Garbutt 66kV	2 × 15MVA <sub>r</sub>
- (4) The shunt reactor bank locations, nominal sizes and quantities for the Ross area comprise the following:

Ross 275kV	2 × 84MVA <sub>r</sub> ; 2 × 29.4MVA <sub>r</sub>
------------	---
- (5) The shunt capacitor bank locations, nominal sizes and quantities for the Strathmore area comprise the following:

Newlands 132kV	1 × 25MVA <sub>r</sub>
Clare South 132kV	1 × 20MVA <sub>r</sub>
Collinsville North 132kV	1 × 20MVA <sub>r</sub>
- (6) The shunt reactor bank locations, nominal sizes and quantities for the Strathmore area comprise the following:

Strathmore 275kV	1 × 84MVA <sub>r</sub>
------------------	------------------------
- (7) The shunt capacitor bank locations, nominal sizes and quantities for the Nebo area comprise the following:

Moranbah 132kV	1 × 52MVA <sub>r</sub>
Pioneer Valley 132kV	1 × 30MVA <sub>r</sub>
Kemmis 132kV	1 × 30MVA <sub>r</sub>
Dysart 132kV	2 × 25MVA <sub>r</sub>
Alligator Creek 132kV	1 × 20MVA <sub>r</sub>
Mackay 33kV	2 × 15MVA <sub>r</sub>
- (8) The shunt reactor bank locations, nominal sizes and quantities for the Nebo area comprise the following:

Nebo 275kV	1 × 84MVA <sub>r</sub> ; 1 × 30MVA <sub>r</sub> ; 1 × 20.2MVA <sub>r</sub>
------------	--
- (9) The shunt capacitor banks nominal sizes and quantities for which may be available to the Nebo Q optimiser comprise the following:

Nebo 275kV	2 × 120MVA <sub>r</sub>
------------	-------------------------

Table D.3 describes three separate limit equations for the Mt Emerald Wind Farm, Sun Metals Solar Farm and Haughton Solar Farm. The Boolean AND operation is applied to the system conditions across a row, if the expression yields a True value then the maximum capacity quoted for the farm in question becomes an argument to a MAX function, if False then zero (0) becomes the argument to the MAX function. The maximum capacity is the result of the MAX function.

**Table D.3** NQ system strength equations

Time of day (Day or Night) (1)	System Conditions							Maximum Capacity (MW)					
	Number of Gladstone units online	Number of Stanwell units online	Number of Callide B units online	Number of Callide C units online	Number of Callide units online (2)	Number of CQ units online (3)	Number of Kareeya units online	Number of Barron units online	NQ Load	Ross + FNQ Load	Mt Emerald WF	Sun Metals SF	Haughton SF
D	≥ 3	≥ 3			≥ 2	≥ 10	≥ 2	≥ 1	> 550	> 250	36	21.4	20
D	≥ 3	≥ 3			≥ 2	≥ 10	≥ 2	≥ 1	> 640	> 340	72	42.8	40
D	≥ 3	≥ 3			≥ 2	≥ 10	≥ 2	≥ 1	> 740	> 440	126	74.9	70
D	≥ 3	≥ 3	≥ 1	≥ 1	≥ 2	≥ 10	≥ 2	≥ 1	> 740	> 440	90	85.6	100
D	≥ 3	≥ 3			≥ 2	≥ 10	4	0	> 550	> 250	36	21.4	20
D	≥ 3	≥ 3			≥ 2	≥ 10	4	0	> 640	> 340	72	42.8	40
D	≥ 3	≥ 3			≥ 2	≥ 10	4	0	> 740	> 440	126	74.9	70
D/N	≥ 3	≥ 3			≥ 2	≥ 10	4	1	> 550	> 250	72	42.8	40
D/N	≥ 3	≥ 3			≥ 2	≥ 10	4	1	> 640	> 340	117	53.5	50
D/N	≥ 3	≥ 3			≥ 2	≥ 10	4	1	> 740	> 440	144	85.6	80
D/N	≥ 3	≥ 3			≥ 2	≥ 10	4	2	> 550	> 250	117	69.6	65
D/N	≥ 3	≥ 3			≥ 2	≥ 10	4	2	> 640	> 340	117	69.6	65
D/N	≥ 3	≥ 3			≥ 2	≥ 10	4	2	> 740	> 440	180	107	100
N	≥ 3	≥ 3			≥ 2	≥ 10	≥ 10	≥ 2	> 550	> 250	72	n/a	n/a
N	≥ 3	≥ 3			≥ 2	≥ 10	≥ 10	≥ 2	> 640	> 340	72	n/a	n/a
N	≥ 3	≥ 3			≥ 2	≥ 10	≥ 10	≥ 2	> 740	> 440	126	n/a	n/a
D	≥ 3	≥ 3	≥ 1	≥ 1	≥ 2	≥ 10	≥ 10	≥ 1	> 450	> 250	0	0	0
D	≥ 3	≥ 3	≥ 1	≥ 1	≥ 2	≥ 10	≥ 10	≥ 1	> 650	> 350	45	26.7	25
D/N	≥ 3	≥ 3			≥ 2	≥ 9	4	0	> 550	> 250	36	21.4	20



**Table D.3** NQ system strength equations (continued)

Time of day (Day or Night) (1)	System Conditions						Maximum Capacity (MW)						
	Number of Gladstone units online	Number of Stanwell units online	Number of Callide B units online	Number of Callide C units online	Number of Callide units online (2)	Number of CQ units online (3)	Number of Kareeya units online	Number of Barron units online	NQ Load	Ross + FNQ Load	Mt Emerald WF	Sun Metals SF	Haughton SF
D/N	≥ 3	≥ 3	≥ 2	≥ 2	≥ 2	≥ 9	4	0	> 640	> 340	72	42.8	40
D/N	≥ 3	≥ 3	≥ 2	≥ 2	≥ 2	≥ 9	4	0	> 740	> 440	117	53.5	50
D/N	≥ 3	≥ 3	≥ 1	≥ 1	≥ 1	≥ 9	≥ 3		> 450	> 250	36	21.4	20
D/N	≥ 3	≥ 3	≥ 1	≥ 1	≥ 1	≥ 9	≥ 3		> 650	> 230	72	42.8	40
N	≥ 3	≥ 3	≥ 1	≥ 1	≥ 1	≥ 9			> 550	> 350	0	n/a	n/a
N	≥ 3	≥ 3	≥ 1	≥ 1	≥ 1	≥ 9			> 650	> 350	72	n/a	n/a
D/N	≥ 3	≥ 2	≥ 1	≥ 1	≥ 1	≥ 8	≥ 3		> 450	> 250	36	21.4	20
D/N	≥ 3	≥ 2	≥ 1	≥ 1	≥ 1	≥ 8	≥ 3	≥ 1	> 450	> 250	72	42.8	40
N	≥ 3	≥ 2	≥ 1	≥ 1	≥ 1	≥ 8	≥ 3		> 450	> 250	36	21.4	20
N	≥ 3	≥ 2	≥ 1	≥ 1	≥ 1	≥ 8	≥ 3	≥ 1	> 450	> 250	72	42.8	40
D/N	≥ 3	≥ 2	≥ 1	≥ 1	≥ 1	≥ 7 and < 10	≥ 2				0	0	0
D/N	≥ 3	≥ 2	≥ 1	≥ 1	≥ 1	≥ 7 and < 10			> 450	> 250	0	0	0
D/N	≥ 3	≥ 2	≥ 1	≥ 1	≥ 1	≥ 8			> 450	> 250	0	0	0
AEMO Constraint ID											Q_NIL_STRGTH_MEWF	Q_NIL_STRGTH_SMSF	Q_NIL_STRGTH_HAUSF

Notes:

- (1) 'Night' conditions refer to the total solar horizontal irradiance at Sun Metals, Haughton, Clare and Ross River < 4 and there are no inverters online at Sun Metals and Haughton.
- (2) Refers to the total number of Callide B and Callide C units online.
- (3) Refers to the number of Gladstone, Stanwell and Callide units online.

System normal equations are implemented for all other north Queensland semi-scheduled generators (Ross River Solar Farm, Kidston Solar Farm, Clare Solar Farm, Whitsunday Solar Farm, Hamilton Solar Farm, Daydream Solar Farm, Hayman Solar Farm, Collinsville Solar Farm and Rugby Run Solar Farm) to ensure system security is maintained during abnormally low synchronous generator dispatches. These equations allow unconstrained operation for all but the last two conditions of Table D.3 where operation is constrained to 80%. Conditions resulting in lower synchronous unit capacity are constrained to 0.

**Table D.4** Central to South Queensland grid section voltage stability equations

Measured variable	Coefficient
Constant term (intercept)	1,015
Total MW generation at Gladstone 275kV and 132kV	0.1407
Number of Gladstone 275kV units on line [2 to 4]	57.5992
Number of Gladstone 132kV units on line [1 to 2]	89.2898
Total MW generation at Callide B and Callide C	0.0901
Number of Callide B units on line [0 to 2]	29.8537
Number of Callide C units on line [0 to 2]	63.4098
Total MW generation in southern Queensland (1)	-0.0650
Number of 90MVAR capacitor banks available at Boyne Island [0 to 2]	51.1534
Number of 50MVAR capacitor banks available at Boyne Island [0 to 1]	25.5767
Number of 120MVAR capacitor banks available at Wurdong [0 to 3]	52.2609
Number of 50MVAR capacitor banks available at Gin Gin [0 to 1]	31.5525
Number of 120MVAR capacitor banks available at Woolooga [0 to 1]	47.7050
Number of 50MVAR capacitor banks available at Woolooga [0 to 2]	22.9875
Number of 120MVAR capacitor banks available at Palmwoods [0 to 1]	30.7759
Number of 50MVAR capacitor banks available at Palmwoods [0 to 4]	14.2253
Number of 120MVAR capacitor banks available at South Pine [0 to 4]	9.0315
Number of 50MVAR capacitor banks available at South Pine [0 to 4]	3.2522
Equation lower limit	1,550
Equation upper limit	2,100 (2)
AEMO Constraint ID	Q^^NIL_CS, Q::NIL_CS

Notes:

- (1) Southern Queensland generation term refers to summated active power generation at Swanbank E, Wivenhoe, Tarong, Tarong North, Condamine, Roma, Kogan Creek, Braemar 1, Braemar 2, Darling Downs, Darling Downs Solar Farm, Oakey, Oakey 1 Solar Farm, Oakey 2 Solar Farm, Yarranlea Solar Farm, Maryrorough Solar Farm, Warwick Solar Farm, Coopers Gap Wind Farm, Millmerran, Susan River Solar Farm, Childers Solar Farm and Terranora Interconnector and Queensland New South Wales Interconnector (QNI) transfers (positive transfer denotes northerly flow).
- (2) The upper limit is due to a transient stability limitation between central and southern Queensland areas.

**Table D.5** Tarong grid section voltage stability equations

Measured variable	Coefficient	
	Equation 1	Equation 2
	Calvale-Halys contingency	Tarong-Blackwall contingency
Constant term (intercept) (1)	740	1,124
Total MW generation at Callide B and Callide C	0.0346	0.0797
Total MW generation at Gladstone 275kV and 132kV	0.0134	–
Total MW in Surat, Bulli and South West and QNI transfer (2)	0.8625	0.7945
Surat/Braemar demand	-0.8625	-0.7945
Total MW generation at Wivenhoe and Swanbank E	-0.0517	-0.0687
Active power transfer (MW) across Terranora Interconnector (2)	-0.0808	-0.1287
Number of 200MVA capacitor banks available (3)	7.6683	16.7396
Number of 120MVA capacitor banks available (4)	4.6010	10.0438
Number of 50MVA capacitor banks available (5)	1.9171	4.1849
Reactive to active demand percentage (6) (7)	-2.9964	-5.7927
Equation lower limit	3,200	3,200
AEMO Constraint ID	Q <sup>^</sup> NIL_TR_CLHA	Q <sup>^</sup> NIL_TR_TRBK

Notes:

- (1) Equations 1 and 2 are offset by -100MW and -150MW respectively when the Middle Ridge to Abermain 110kV loop is run closed.
- (2) Surat, Bulli and South West generation term refers to summated active power generation at generation at Tarong, Tarong North, Roma, Condamine, Kogan Creek, Braemar 1, Braemar 2, Darling Downs, Darling Downs Solar Farm, Coopers Gap Wind Farm, Oakey, Oakey 1 Solar Farm, Oakey 2 Solar Farm, Yarranlea Solar Farm, Maryrorough Solar Farm, Warwick Solar Farm, Millmerran and QNI transfers (positive transfer denotes northerly flow).
- (3) There are currently 4 capacitor banks of nominal size 200MVA which may be available within this area.
- (4) There are currently 18 capacitor banks of nominal size 120MVA which may be available within this area.
- (5) There are currently 38 capacitor banks of nominal size 50MVA which may be available within this area.
- (6) Reactive to active demand percentage =  $\frac{\text{Zone reactive demand}}{\text{Zone active demand}} \times 100$   
 Zone reactive demand (MVA) = Reactive power transfers into the 110kV measured at the 132/110kV transformers at Palmwoods and 275/110kV transformers inclusive of south of South Pine and east of Abermain + reactive power generation from 50MVA shunt capacitor banks within this zone + reactive power transfer across Terranora Interconnector.  
 Zone active demand (MW) = Active power transfers into the 110kV measured at the 132/110kV transformers at Palmwoods and the 275/110kV transformers inclusive of south of South Pine and east of Abermain + active power transfer on Terranora Interconnector.
- (7) The reactive to active demand percentage is bounded between 10 and 35.

**Table D.6** Gold Coast grid section voltage stability equation

Measured variable	Coefficient
Constant term (intercept)	1,351
Moreton to Gold Coast demand ratio (1) (2)	-137.50
Number of Wivenhoe units on line [0 to 2]	17.7695
Number of Swanbank E units on line [0 to 1]	-20.0000
Active power transfer (MW) across Terranora Interconnector (3)	-0.9029
Reactive power transfer (MVA <sub>r</sub> ) across Terranora Interconnector (3)	0.1126
Number of 200MVA <sub>r</sub> capacitor banks available (4)	14.3339
Number of 120MVA <sub>r</sub> capacitor banks available (5)	10.3989
Number of 50MVA <sub>r</sub> capacitor banks available (6)	4.9412
AEMO Constraint ID	Q^NIL_GC

Notes:

- (1) Moreton to Gold Coast demand ratio =  $\frac{\text{Moreton zone active demand}}{\text{Gold Coast zone active demand}} \times 100$
- (2) The Moreton to Gold Coast demand ratio is bounded between 4.7 and 6.0.
- (3) Positive transfer denotes northerly flow.
- (4) There are currently 4 capacitor banks of nominal size 200MVA<sub>r</sub> which may be available within this area.
- (5) There are currently 16 capacitor banks of nominal size 120MVA<sub>r</sub> which may be available within this area.
- (6) There are currently 34 capacitor banks of nominal size 50MVA<sub>r</sub> which may be available within this area.

## Appendix E Indicative short circuit currents

Tables E.1 to E.3 show indicative maximum and minimum short circuit currents at Powerlink Queensland's substations.

### Indicative maximum short circuit currents

Tables E.1 to E.3 show indicative maximum symmetrical three phase and single phase to ground short circuit currents in Powerlink's transmission network for summer 2020/21, 2021/22 and 2022/23.

These results include the short circuit contribution of some of the more significant embedded non-scheduled generators, however smaller embedded non-scheduled generators may have been excluded. As a result, short circuit currents may be higher than shown at some locations. Therefore, this information should be considered as an indicative guide to short circuit currents at each location and interested parties should consult Powerlink and/or the relevant Distribution Network Service Provider (DNSP) for more detailed information.

The maximum short circuit currents were calculated:

- using a system model, in which generators were represented as a voltage source of 110% of nominal voltage behind sub-transient reactance
- with all model shunt elements removed.

The short circuit currents shown in tables E.1 to E.3 are based on generation shown in tables 6.1 and 6.2 (together with any of the more significant embedded non-scheduled generators) and on the committed network development as at the end of each calendar year. The tables also show the rating of the lowest rated Powerlink owned plant at each location. No assessment has been made of the short circuit currents within networks owned by DNSPs or directly connected customers, nor has an assessment been made of the ability of their plant to withstand and/or interrupt the short circuit current.

The maximum short circuit currents presented in this appendix are based on all generating units online and an 'intact' network, that is, all network elements are assumed to be in-service. This assumption can result in short circuit currents appearing to be above plant rating at some locations. Where this is found, detailed assessments are made to determine if the contribution to the total short circuit current that flows through the plant exceeds its rating. If so, the network may be split to create 'normally-open' point as an operational measure to ensure that short circuit currents remain within the plant rating, until longer term solutions can be justified.

### Indicative minimum short circuit currents

Minimum short circuit currents are used to inform the capacity of the system to accommodate fluctuating loads and power electronic connected systems (including non-synchronous generators and Static VAr Compensators (SVCs)). Minimum short circuit currents are also important in ensuring power system quality and stability and for ensuring the proper operation of protection systems.

Tables E.1 to E.3 show indicative minimum system normal and post-contingent symmetrical three phase short circuit currents at Powerlink's substations. These were calculated by analysing half hourly system normal snapshots over the period 1 July 2019 and 30 June 2020. The minimum of subtransient, transient and synchronous short circuit currents over the year were compiled for each substation, both for system normal and with the individual outage of each significant network element.

These minimum short circuit currents are indicative only, and as they are based on history are distinct from the minimum fault level published in the [System Strength Requirements Methodology](#), [System Strength Requirements and Fault Level Shortfalls](#) published by AEMO in July 2018.

**Table E.1** Indicative short circuit currents – northern Queensland – 2020/21 to 2022/23

Substation	Voltage (kV)	Plant Rating (lowest kA)	Indicative minimum system normal fault level (kA)	Indicative minimum post-contingent fault level (kA)	Indicative maximum short circuit currents					
					2020/21		2021/22		2022/23	
					3 phase (kA)	L – G (kA)	3 phase (kA)	L – G (kA)	3 phase (kA)	L – G (kA)
Alan Sherriff	132	40.0	4.3	3.9	13.5	13.8	13.7	13.9	13.7	13.9
Alligator Creek	132	25.0	3.0	1.6	4.6	6.1	4.6	6.1	4.6	6.1
Bolingbroke	132	40.0	1.9	1.8	2.5	1.9	2.5	1.9	2.5	1.9
Bowen North	132	40.0	3.1	1.9	2.8	3.0	2.8	3.1	2.9	3.2
Cairns (2T)	132	25.0	2.8	0.7	5.9	7.8	5.9	7.8	5.9	7.8
Cairns (3T)	132	25.0	2.8	0.7	5.9	7.8	5.9	7.8	5.9	7.8
Cairns (4T)	132	25.0	2.8	0.7	5.9	7.8	5.9	7.9	-	-
Cardwell	132	19.3	1.9	0.9	3.1	3.3	3.1	3.3	3.1	3.3
Chalumbin	275	31.5	1.7	1.3	4.2	4.4	4.2	4.4	4.2	4.4
Chalumbin	132	31.5	3.1	2.4	6.5	7.5	6.6	7.6	6.6	7.6
Clare South	132	40.0	3.5	3.0	7.9	8.0	8.0	8.1	8.1	8.2
Collinsville North	132	31.5	4.6	2.3	8.7	9.6	8.8	9.7	11.3	12.2
Coppabella	132	31.5	2.0	1.3	3.1	3.4	3.1	3.4	3.1	3.4
Crush Creek	275	40.0	3.2	2.8	9.5	10.7	9.8	11.0	10.0	11.3
Dan Gleeson (IT)	132	31.5	4.3	3.7	12.8	13.2	13.0	13.3	13.0	13.3
Dan Gleeson (2T)	132	40.0	4.3	3.7	12.8	13.3	13.0	13.4	13.0	13.4
Edmonton	132	40.0	1.3	0.4	5.3	6.6	5.4	6.6	5.4	6.6
Eagle Downs	132	40.0	2.7	1.4	4.6	4.4	4.6	4.5	4.6	4.5
El Arish	132	40.0	2.0	0.9	3.3	4.0	3.3	4.0	3.3	4.0
Garbutt	132	40.0	4.0	1.8	11.1	11.0	11.2	11.0	11.2	11.0
Goonyella Riverside	132	40.0	3.2	2.8	5.9	5.4	5.9	5.4	6.0	5.5
Haughton River	275	40.0	2.6	2.1	7.2	7.2	7.7	8.0	7.8	8.0
Ingham South	132	31.5	1.9	0.9	3.3	3.4	3.3	3.4	3.3	3.4
Innisfail	132	40.0	1.9	1.2	3.0	3.6	3.0	3.6	3.0	3.6
Invicta	132	19.3	2.6	1.6	5.3	4.7	5.3	4.8	5.3	4.8
Kamerunga	132	15.3	2.3	0.5	4.5	5.4	4.5	5.4	4.5	5.4
Kareeya	132	40.0	2.7	2.2	5.6	6.3	5.6	6.3	5.6	6.3
Kemmis	132	31.5	3.8	1.5	6.1	6.6	6.1	6.7	6.1	6.7
King Creek	132	40.0	2.8	1.4	4.7	4.0	4.7	4.0	5.3	4.3
Lake Ross	132	31.5	4.9	4.4	17.7	19.7	18.0	20.0	18.0	20.0
Mackay	132	10.9	2.8	0.9	5.8	6.8	5.8	6.8	5.8	6.8

**Table E.1** Indicative short circuit currents – northern Queensland – 2020/21 to 2022/23 (continued)

Substation	Voltage (kV)	Plant Rating (lowest kA)	Indicative minimum system normal fault level (kA)	Indicative minimum post-contingent fault level (kA)	Indicative maximum short circuit currents					
					2020/21		2021/22		2022/23	
					3 phase (kA)	L – G (kA)	3 phase (kA)	L – G (kA)	3 phase (kA)	L – G (kA)
Mackay Ports	132	40.0	2.4	1.5	3.5	4.2	3.5	4.2	3.5	4.2
Mindi	132	40.0	3.1	2.9	4.9	3.7	4.9	3.7	4.9	3.7
Moranbah	132	10.9	3.7	2.9	7.9	9.3	7.9	9.3	8.0	9.3
Moranbah Plains	132	40.0	2.1	1.8	4.4	4.0	4.4	4.0	4.4	4.0
Moranbah South	132	31.5	3.0	2.5	5.7	5.2	5.7	5.2	5.7	5.2
Mt McLaren	132	31.5	1.5	1.3	2.1	2.3	2.1	2.3	2.1	2.3
Nebo	275	31.5	3.8	3.3	10.7	10.9	10.9	11.1	10.9	11.1
Nebo	132	25.0	6.4	5.6	13.9	15.9	14.1	16.0	14.1	16.0
Newlands	132	25.0	2.3	1.2	3.5	3.9	3.5	3.9	3.6	4.0
North Goonyella	132	20.0	2.7	0.9	4.4	3.7	4.5	3.7	4.5	3.7
Oonooie	132	31.5	2.2	1.3	3.2	3.7	3.2	3.7	3.2	3.7
Peak Downs	132	31.5	2.5	1.4	4.2	3.7	4.2	3.7	4.2	3.7
Pioneer Valley	132	31.5	4.0	3.4	7.2	8.0	7.2	8.0	7.2	8.0
Proserpine	132	40.0	2.2	1.5	3.2	3.8	3.3	3.8	3.5	4.1
Ross	275	31.5	2.7	2.4	8.6	9.6	9.0	10.0	9.0	10.0
Ross	132	31.5	4.9	4.4	18.2	20.5	18.6	20.9	18.6	20.9
Springlands	132	40.0	4.9	2.4	9.6	10.7	9.7	10.8	11.5	12.8
Stony Creek	132	40.0	2.4	1.1	3.6	3.5	3.6	3.6	3.8	3.7
Strathmore	275	31.5	3.2	2.8	9.6	10.8	9.9	11.1	10.1	11.5
Strathmore (IT)	132	40.0	5.0	2.4	9.8	11.2	9.9	11.3	11.8	13.5
Townsville East	132	40.0	4.1	1.6	13.1	12.6	13.2	12.7	13.2	12.7
Townsville South	132	21.9	4.5	4.1	17.8	21.4	18.1	21.6	18.1	21.6
Townsville GT PS	132	31.5	3.7	2.4	10.7	11.2	10.8	11.3	10.8	11.3
Tully	132	31.5	2.4	1.9	4.0	4.2	4.1	4.2	4.1	4.2
Turkinje	132	20.0	1.7	1.1	2.7	3.1	2.7	3.1	2.7	3.1
Walkamin	275	40.0	1.5	0.9	3.2	3.7	3.2	3.7	3.2	3.7
Wandoo	132	31.5	3.1	2.9	4.5	3.3	4.6	3.3	4.6	3.3
Woree (IT)	275	40.0	1.4	0.9	2.8	3.2	2.8	3.3	2.8	3.3
Woree (2T)	275	40.0	1.4	0.9	2.8	3.3	2.9	3.4	2.9	3.4
Woree	132	40.0	2.9	2.4	6.1	8.4	6.1	8.4	6.1	8.4
Wotonga	132	40.0	3.3	1.4	6.2	7.2	6.2	7.2	6.2	7.2
Yabulu South	132	40.0	4.2	3.8	12.8	12.1	13.0	12.2	13.0	12.2

**Table E.2** Indicative short circuit currents – CQ – 2020/21 to 2022/23

Substation	Voltage (kV)	Plant Rating (lowest kA)	Indicative minimum system normal fault level (kA)	Indicative minimum post-contingent fault level (kA)	Indicative maximum short circuit currents					
					2020/21		2021/22		2022/23	
					3 phase (kA)	L – G (kA)	3 phase (kA)	L – G (kA)	3 phase (kA)	L – G (kA)
Baralaba	132	15.3	3.4	2.4	4.2	3.6	4.4	3.7	4.4	3.7
Biloela	132	20.0	3.8	1.0	7.8	8.1	8.1	8.3	8.1	8.3
Blackwater	132	10.9	3.9	3.4	5.9	7.1	5.9	7.1	5.9	7.0
Bluff	132	40.0	2.5	2.3	3.5	4.3	3.5	4.3	3.5	4.3
Bouldercombe	275	31.5	6.4	5.8	20.3	19.6	20.5	19.8	20.5	19.8
Bouldercombe	132	21.8	7.7	4.3	11.5	13.6	14.4	16.8	14.4	16.8
Broadsound	275	31.5	4.8	4.1	12.3	9.3	12.5	9.4	12.5	9.4
Bundoorra	132	31.5	2.5	0.8	9.2	8.9	9.3	9.1	9.3	9.0
Callemondah	132	31.5	9.6	5.3	22.1	24.7	22.4	24.9	22.4	24.9
Calliope River	275	40.0	6.5	5.9	20.9	23.7	21.5	24.4	21.5	24.5
Calliope River	132	40.0	10.1	8.5	24.7	29.8	25.1	30.2	25.1	30.2
Calvale	275	31.5	7.1	6.1	23.5	26.0	23.8	26.2	23.8	26.2
Calvale (1T)	132	31.5	7.5	4.5	8.7	9.6	8.9	9.8	8.9	9.8
Calvale (2T)	132	40.0	7.4	4.5	8.4	9.3	8.6	9.4	8.6	9.4
Duaranga	132	40.0	1.7	0.9	2.3	2.9	2.3	2.9	2.3	2.9
Dysart	132	10.9	2.8	1.6	4.8	5.4	4.8	5.4	4.8	5.4
Egans Hill	132	25.0	5.3	1.4	7.2	7.4	8.3	8.2	8.3	8.2
Gladstone PS	275	40.0	6.3	5.7	19.4	21.6	20.0	22.2	20.0	22.2
Gladstone PS	132	40.0	9.2	7.9	21.8	25.0	22.0	25.2	22.0	25.2
Gladstone South	132	40.0	8.1	6.8	16.2	17.2	16.4	17.3	16.4	17.3
Grantleigh	132	31.5	2.1	1.7	2.6	2.7	2.7	2.8	2.7	2.8
Gregory	132	31.5	5.4	4.4	10.2	11.3	10.3	11.6	10.3	11.5
Larcom Creek	275	40.0	5.8	3.0	15.5	15.3	15.7	15.5	15.7	15.5
Larcom Creek	132	40.0	6.4	3.7	12.3	13.8	12.4	13.8	12.4	13.8
Lilyvale	275	31.5	3.2	2.5	6.3	6.0	6.3	6.2	6.3	6.1
Lilyvale	132	25.0	5.6	4.6	10.8	12.3	10.9	12.8	10.8	12.6
Moura	132	40.0	2.9	1.6	3.9	4.2	4.4	4.6	4.4	4.6
Norwich Park	132	31.5	2.3	1.0	3.7	2.7	3.7	2.7	3.7	2.7
Pandoin	132	40.0	4.6	1.1	6.2	5.5	6.9	6.0	6.9	6.0
Raglan	275	40.0	5.4	3.7	12.0	10.4	12.1	10.5	12.1	10.5
Rockhampton (1T)	132	40.0	4.4	1.6	5.8	5.9	6.4	6.3	6.4	6.3
Rockhampton (5T)	132	40.0	4.3	1.6	5.6	5.7	6.2	6.1	6.2	6.1



**Table E.2** Indicative short circuit currents – CQ – 2020/21 to 2022/23 (continued)

Substation	Voltage (kV)	Plant Rating (lowest kA)	Indicative minimum system normal fault level (kA)	Indicative minimum post-contingent fault level (kA)	Indicative maximum short circuit currents					
					2020/21		2021/22		2022/23	
					3 phase (kA)	L – G (kA)	3 phase (kA)	L – G (kA)	3 phase (kA)	L – G (kA)
Rocklands	132	31.5	5.0	3.3	6.8	6.1	7.7	6.6	7.7	6.6
Stanwell	275	31.5	6.6	5.9	23.1	24.5	23.3	24.8	23.3	24.8
Stanwell	132	31.5	4.1	2.8	5.4	6.0	5.9	6.4	5.9	6.4
Wurdong	275	31.5	6.1	5.0	16.7	16.6	17.4	17.6	17.4	17.6
Wycarbah	132	40.0	3.2	2.4	4.2	5.1	4.5	5.4	4.5	5.4
Yarwun	132	40.0	6.3	4.1	12.9	14.9	12.9	14.9	12.9	14.9

**Table E.3** Indicative short circuit currents – southern Queensland – 2020/21 to 2022/23

Substation	Voltage (kV)	Plant Rating (lowest kA)	Indicative minimum system normal fault level (kA)	Indicative minimum post-contingent fault level (kA)	Indicative maximum short circuit currents					
					2020/21		2021/22		2022/23	
					3 phase (kA)	L – G (kA)	3 phase (kA)	L – G (kA)	3 phase (kA)	L – G (kA)
Abermain	275	40.0	6.3	5.3	18.2	18.7	18.3	18.8	18.3	18.8
Abermain	110	31.5	11.6	9.6	21.5	24.5	21.5	24.5	21.5	24.5
Algerger	110	40.0	11.7	10.6	21.0	20.8	21.1	20.9	21.1	20.9
Ashgrove West	110	26.3	11.0	8.8	19.1	20.1	19.2	20.1	19.2	20.1
Belmont	275	31.5	6.2	5.6	16.9	17.8	17.1	17.9	17.1	17.9
Belmont	110	37.4	13.9	12.8	27.7	34.4	27.9	34.5	27.9	34.5
Blackstone	275	40.0	6.5	5.9	21.2	23.3	21.4	23.4	21.4	23.4
Blackstone	110	40.0	12.7	11.7	25.4	27.9	25.5	28.0	25.5	28.0
Blackwall	275	37.0	6.7	6.0	22.4	24.1	22.7	24.3	22.7	24.3
Blythdale	132	40.0	3.2	2.2	4.2	5.2	4.2	5.2	4.2	5.2
Braemar	330	50.0	5.6	5.1	23.7	25.7	24.2	26.2	24.2	26.2
Braemar (East)	275	40.0	6.5	4.5	27.0	31.3	27.4	31.7	27.4	31.7
Braemar (West)	275	40.0	6.4	4.4	27.6	30.4	28.5	31.3	28.5	31.3
Bulli Creek	330	50.0	5.8	3.2	18.5	14.5	18.6	14.6	18.6	14.6
Bulli Creek	132	40.0	2.8	2.5	3.8	4.3	3.8	4.3	3.8	4.3
Bundamba	110	40.0	10.2	7.4	17.2	16.6	17.3	16.6	17.3	16.6
Chinchilla	132	25.0	4.9	3.9	8.2	7.9	8.7	8.4	8.7	8.4
Clifford Creek	132	40.0	4.1	3.4	5.7	5.2	5.8	5.2	5.8	5.2
Columboola	275	40.0	5.1	4.1	13.1	12.3	13.7	12.8	13.7	12.8
Columboola	132	25.0	7.4	5.0	17.4	20.3	18.3	21.2	18.3	21.2
Condabri North	132	40.0	6.5	5.0	13.9	12.9	14.5	13.2	14.5	13.2
Condabri Central	132	40.0	5.1	4.0	9.2	6.8	9.5	6.9	9.5	6.9
Condabri South	132	40.0	4.0	3.3	6.7	4.5	6.8	4.5	6.8	4.5
Coopers Gap	275	40.0	6.2	3.1	17.6	17.5	17.8	17.6	17.8	17.6
Dinoun South	132	40.0	4.6	3.7	6.5	6.8	6.7	6.9	6.7	6.9
Eurombah (1T)	275	40.0	2.8	1.1	4.4	4.6	4.5	4.7	4.5	4.7
Eurombah (2T)	275	40.0	2.8	1.1	4.3	4.6	4.3	4.6	4.3	4.6
Eurombah	132	40.0	4.7	3.5	6.9	8.5	7.1	8.6	7.1	8.6
Fairview	132	40.0	3.0	2.4	4.0	5.0	4.0	5.1	4.0	5.1
Fairview South	132	40.0	3.8	2.9	5.2	6.6	5.3	6.7	5.3	6.7
Gin Gin	275	14.5	5.4	4.9	9.2	8.6	9.5	8.8	9.5	8.8
Gin Gin	132	20.0	7.5	5.6	12.0	13.0	12.3	13.2	12.3	13.2

**Table E.3** Indicative short circuit currents – southern Queensland – 2020/21 to 2022/23 (continued)

Substation	Voltage (kV)	Plant Rating (lowest kA)	Indicative minimum system normal fault level (kA)	Indicative minimum post-contingent fault level (kA)	Indicative maximum short circuit currents					
					2020/21		2021/22		2022/23	
					3 phase (kA)	L – G (kA)	3 phase (kA)	L – G (kA)	3 phase (kA)	L – G (kA)
Goodna	275	40.0	6.1	4.9	16.2	16.0	16.4	16.1	16.4	16.1
Goodna	110	40.0	12.7	11.5	25.4	27.5	25.5	27.6	25.5	27.6
Greenbank	275	40.0	6.5	5.8	20.5	22.5	20.6	22.6	20.6	22.6
Halys	275	50.0	7.5	6.7	32.6	28.2	33.1	28.5	33.1	28.5
Kumbarilla Park (1T)	275	40.0	5.7	1.6	16.8	16.2	16.8	16.2	16.8	16.2
Kumbarilla Park (2T)	275	40.0	5.7	1.6	16.7	16.1	16.9	16.2	16.9	16.2
Kumbarilla Park	132	40.0	7.7	5.2	13.2	15.2	13.2	15.2	13.2	15.2
Loganlea	275	40.0	5.9	5.2	15.0	15.4	15.0	15.4	15.0	15.4
Loganlea	110	31.5	12.5	11.4	22.7	27.3	22.8	27.3	22.8	27.3
Middle Ridge (4T)	330	50.0	5.1	3.1	12.8	12.3	12.8	12.4	12.8	12.4
Middle Ridge (5T)	330	50.0	5.0	3.1	13.1	12.8	13.2	12.8	13.2	12.8
Middle Ridge	275	31.5	6.4	5.7	18.3	18.4	18.4	18.5	18.4	18.5
Middle Ridge	110	18.3	9.6	8.1	21.7	25.6	21.7	25.6	21.7	25.6
Millmerran	330	40.0	5.6	4.9	18.6	19.8	18.7	19.9	18.7	19.9
Molendinar (1T)	275	40.0	4.5	2.0	8.3	8.1	8.3	8.1	8.3	8.1
Molendinar (2T)	275	40.0	4.5	2.0	8.3	8.1	8.3	8.1	8.3	8.1
Molendinar	110	40.0	11.3	10.1	20.1	25.3	20.1	25.4	20.1	25.4
Mt England	275	31.5	6.6	6.1	22.7	22.9	23.0	23.1	23.0	23.1
Mudgeeraba	275	31.5	4.9	4.1	9.5	9.4	9.5	9.4	9.5	9.4
Mudgeeraba	110	25.0	10.8	10.0	18.7	22.9	18.8	22.9	18.8	22.9
Murarrie (1T)	275	40.0	5.7	2.4	13.2	13.2	13.3	13.2	13.3	13.2
Murarrie (2T)	275	40.0	5.7	2.4	13.2	13.3	13.2	13.3	13.2	13.3
Murarrie	110	40.0	12.7	11.5	23.8	28.7	23.8	28.8	23.8	28.8
Oakey Gt	110	31.5	4.7	1.1	11.4	12.5	11.4	12.5	11.4	12.5
Oakey	110	40.0	4.5	1.1	10.2	10.1	10.2	10.1	10.2	10.1
Orana	275	40.0	5.4	3.2	15.3	14.0	15.9	14.6	15.9	14.6
Palmwoods	275	31.5	4.9	3.2	8.5	9.0	8.8	9.2	8.8	9.2
Palmwoods	132	21.9	6.6	5.3	13.1	15.8	13.5	16.2	13.5	16.2
Palmwoods (7T)	110	40.0	5.5	2.6	7.3	7.6	7.3	7.6	7.3	7.6
Palmwoods (8T)	110	40.0	5.5	2.6	7.3	7.6	7.3	7.6	7.3	7.6

**Table E.3** Indicative short circuit currents – southern Queensland – 2020/21 to 2022/23 (continued)

Substation	Voltage (kV)	Plant Rating (lowest kA)	Indicative minimum system normal fault level (kA)	Indicative minimum post-contingent fault level (kA)	Indicative maximum short circuit currents					
					2020/21		2021/22		2022/23	
					3 phase (kA)	L – G (kA)	3 phase (kA)	L – G (kA)	3 phase (kA)	L – G (kA)
Redbank Plains	110	31.5	11.5	8.9	21.3	20.6	21.4	20.7	21.4	20.7
Richlands	110	40.0	11.8	10.2	21.8	22.6	21.9	22.6	21.9	22.6
Rocklea (1T)	275	31.5	5.7	2.3	13.2	12.3	13.3	12.3	13.3	12.3
Rocklea (2T)	275	31.5	4.8	2.3	8.8	8.4	8.8	8.5	8.8	8.5
Rocklea	110	31.5	12.8	11.6	24.9	28.7	25.1	28.8	25.1	28.8
Runcorn	110	40.0	11.0	8.2	18.8	19.2	18.8	19.2	18.8	19.2
South Pine	275	31.5	6.5	5.9	18.8	21.3	19.2	21.6	19.2	21.6
South Pine (West)	110	40.0	11.2	9.5	20.5	23.5	20.6	23.6	20.6	23.6
South Pine (East)	110	40.0	11.6	10.2	21.6	27.6	21.8	27.9	21.8	27.9
Sumner	110	40.0	11.4	8.6	20.6	20.2	20.7	20.3	20.7	20.3
Swanbank E	275	40.0	6.5	5.8	20.8	22.7	21.0	22.8	21.0	22.8
Tangkam	110	31.5	5.5	3.5	13.5	12.5	13.5	12.5	13.5	12.5
Tarong	275	31.5	7.5	6.7	34.0	35.8	34.5	36.2	34.5	36.2
Tarong (1T)	132	25.0	4.4	1.0	5.8	6.0	5.8	6.0	5.8	6.0
Tarong (4T)	132	31.5	4.5	1.0	5.8	6.1	5.8	6.1	5.8	6.1
Tarong	66	40.0	10.4	5.9	15.0	16.2	15.0	16.2	15.0	16.2
Teebar Creek	275	40.0	4.4	2.8	7.3	7.0	7.7	7.4	7.7	7.4
Teebar Creek	132	40.0	6.4	4.7	10.8	11.6	11.1	11.9	11.1	11.9
Tennyson	110	40.0	9.7	1.5	16.2	16.4	16.3	16.4	16.3	16.4
Upper Kedron	110	40.0	11.7	10.4	21.2	18.7	21.3	18.8	21.3	18.8
Wandoan South	275	40.0	3.9	3.1	7.4	8.2	7.8	8.5	7.8	8.5
Wandoan South	132	40.0	5.8	4.4	9.2	12.0	9.9	12.7	9.9	12.7
West Darra	110	40.0	12.6	11.5	24.9	23.8	25.0	23.9	25.0	23.9
Western Downs	275	40.0	6.3	4.8	25.9	25.2	27.4	28.6	27.4	28.6
Woolooga	275	31.5	5.2	4.5	10.0	11.2	10.8	12.2	10.8	12.2
Woolooga	132	25.0	8.4	6.9	13.4	15.7	15.2	18.4	15.2	18.4
Yuleba North	275	40.0	3.4	2.8	6.0	6.6	6.2	6.7	6.2	6.7
Yuleba North	132	40.0	5.2	4.1	7.8	9.5	8.0	9.7	8.0	9.7

## Appendix F Compendium of potential non-network solution opportunities within the next five years

**Table F.1** Potential non-network solution opportunities within the next five years

Potential project	Indicative cost (most likely network option)	Zone	Indicative non-network requirement	Possible commissioning date	TAPR Reference
Transmission lines					
Woree to Kamerunga 132kV transmission line replacement	\$40m	Far North	Up to 70MW at peak and up to 1,200MWh per day on a continuous basis to provide supply to the 22kV network	December 2026	<a href="#">Section 5.7.1</a>
Line refit works on the 275kV transmission lines between Chalumbin and Woree substations	\$30 to \$40m	Far North	Over 275MW at peak and up to 4,000MWh per day to provide supply to the Cairns area, facilitating the provision of system strength and voltage control	December 2024	<a href="#">Section 5.7.1</a>
Line refit works on the 275kV transmission lines between Ross and Chalumbin substations	\$85 to \$165m	Far North	Over 400MW at peak and up to 7,000MWh to provide supply to the Far North area, facilitating the provision of system strength and voltage control	December 2026	<a href="#">Section 5.7.1</a>
Line refit works on the 275kV transmission line between Calliope River and Larcom Creek	\$10m	Gladstone	Up to 160MW at peak and up to 3,200MWh per day on a continuous basis to provide supply to the 66kV and 132kV loads at Yarwun and Raglan	June 2024	<a href="#">Section 5.7.5</a>
Line refit works on the 275kV transmission line between Wurdong and Boyne	\$7m	Gladstone	Up to 400MW at peak and up to 10,000MWh per day on a continuous basis to supply the 275kV network at Boyne Island	December 2024	<a href="#">Section 5.7.5</a>
Line refit works on the 132kV transmission line between Callemondah and Gladstone South substations	\$17m	Gladstone	Up to 160MW and up to 1,820MWh per day	December 2023	<a href="#">Section 5.7.5</a>
Rebuild of two of the three transmission lines between Calliope River and Wurdong tee as a double circuit	\$27m	Wide Bay	Powerlink would consider proposals from non-network providers that can significantly contribute to reducing the load requirement in this region. However, this would result in material intra-regional impacts and other impacts.	June 2024	<a href="#">Section 5.7.6</a>
Line refit works on the remaining single circuit 275kV transmission line between Calliope River Substation and Wurdong Tee	\$6m	Wide Bay	Powerlink would consider proposals from non-network providers that can significantly contribute to reducing the load requirement in this region. However, this would result in material intra-regional impacts and other impacts.	June 2026	<a href="#">Section 5.7.6</a>

**Table F.1** Potential non-network solution opportunities within the next five years (*continued*)

Potential project	Indicative cost (most likely network option)	Zone	Indicative non-network requirement	Possible commissioning date	TAPR Reference
Line refit works on the 275kV transmission line between Woolooga and South Pine substations	\$20m to \$30m	Wide Bay	Powerlink would consider proposals from non-network providers that can significantly contribute to reducing the load requirement in this region. However, this would result in material intra-regional other impacts.	June 2026	<a href="#">Section 5.7.6</a>
Replacement of the 110kV underground cable between Upper Kedron and Ashgrove West substations	\$13m	Moreton	Up to 220MW at peak to Brisbane's inner north-west suburb (potentially coupled with network reconfiguration)	June 2026	<a href="#">Section 5.7.10</a>
Line refit works on sections of the 275kV transmission line between Greenbank and Mudgeeraba substations	\$30m to \$50m	Gold Coast	Proposals which may significantly contribute to reducing the requirements in the transmission into the southern Gold Coast and northern NSW area	December 2028	<a href="#">Section 5.7.11</a>
<b>Substations - primary plant and secondary systems (excluding transformers)</b>					
Innisfail 132kV secondary systems replacement	\$11m	Far North	Up to 30MW at peak and 560MWh per day on a continuous basis to provide supply to the 22kV network at Innisfail	December 2024	<a href="#">Section 5.7.1</a>
Chalumbin 132kV secondary systems replacement	\$5m	Far North	Up to 400MW at peak and up to 7,000MWh per day on a continuous basis to supply the 275kV network	December 2025	<a href="#">Section 5.7.1</a>
Edmonton 132kV secondary systems replacement	\$6m	Far North	Up to 55MW at peak and up to 770MWh per day on a continuous basis to provide supply to the 22kV network at Edmonton	June 2026	<a href="#">Section 5.7.1</a>
Ingham South 132kV secondary systems replacement	\$6m	Ross	Up to 20MW at peak and up to 280MWh per day on a continuous basis to provide supply to the 66kV network at Ingham South	June 2025	<a href="#">Section 5.7.2</a>
Alan Sherriff 132kV secondary systems replacement	\$11m	Ross	Up to 25MW at peak and up to 450MWh per day to provide supply to the 11kV network in north-east Townsville	June 2025	<a href="#">Section 5.7.2</a>
Strathmore SVC secondary systems replacement	\$6m	Ross	Up to 150MVAr capacitive and 80MVAr inductive dynamic voltage support at Strathmore	June 2026	<a href="#">Section 5.7.2</a>

**Table F.1** Potential non-network solution opportunities within the next five years (*continued*)

Potential project	Indicative cost (most likely network option)	Zone	Indicative non-network requirement	Possible commissioning date	TAPR Reference
Broadsound 150MVAr 300kV bus reactor	\$9m	Central West	Equivalent to the proposed reactor at or near Nebo or Broadsound, being 126MVAr at the 275kV bus on a continuous basis and not coupled to generation output.	June 2023	<a href="#">Section 5.7.4</a>
Callemondah Substation primary plant and secondary systems replacement	\$7m	Central West	Up to 180MW at peak and up to 2,500MWh per day on a continuous basis to provide supply to the 132kV network at Gladstone South and/or Aurizon load at Callemondah	June 2024	<a href="#">Section 5.7.4</a>
Network reconfiguration by replacement of the two 275/66kV transformers at Tarong Substation	\$16m	South West	Up to 50MW and up to 850MWh per day on a continuous basis	June 2024	<a href="#">Section 5.7.7</a>
Transformer ending Chinchilla substation from Columboola substation	\$8m	South West	Up to 25MW at peak and up to 400MWh per day on a continuous basis	June 2024	<a href="#">Section 5.7.7</a>
Chinchilla 132kV primary plant and secondary systems replacement	\$8m	South West	Up to 25MW at peak and up to 400MWh per day on a continuous basis	June 2024	<a href="#">Section 5.7.7</a>
One bus reactor each at Woolooga, Blackstone and Greenbank substations	\$27m	Moreton	Additional voltage control equivalent to the proposed reactors at various locations in south east Queensland on a continuous basis	December 2023	<a href="#">Section 5.7.10</a>
Murarrie 110kV secondary systems replacement	\$21m	Moreton	Proposals which may significantly contribute to reducing the requirements in the transmission network into the CBD and south-eastern suburbs of Brisbane of over 300MW	June 2025	<a href="#">Section 5.7.10</a>
Ashgrove West 110kV secondary systems replacement	\$6m	Moreton	Up to 220MW at peak to Brisbane's inner north-west suburb (potentially coupled with network reconfiguration)	June 2025	<a href="#">Section 5.7.10</a>
Mudgeeraba 110kV secondary systems replacement	\$11m	Gold Coast	Proposals which may significantly contribute to reducing the requirements in the transmission into the southern Gold Coast and northern NSW area	December 2025	<a href="#">Section 5.7.11</a>
Mudgeeraba 275 and 110kV primary plant replacement	\$20m	Gold Coast	Proposals which may significantly contribute to reducing the requirements in the transmission into the southern Gold Coast and northern NSW area	December 2025	<a href="#">Section 5.7.11</a>

**Table F.1** Potential non-network solution opportunities within the next five years (*continued*)

Potential project	Indicative cost (most likely network option)	Zone	Indicative non-network requirement	Possible commissioning date	TAPR Reference
Substations - transformers					
Tully 132/22kV transformer replacement	\$5m	Far North	Up to 15MW at peak and up to 270MWh per day to provide supply to the 22kV network at Tully	June 2024	<a href="#">Section 5.7.1</a>
Tarong 275/66kV transformers replacement	\$16m	South West	Full network support – up to 50MW at peak and up to 850MWh per day on a continuous basis as well as auxiliary supply of up to 38MVA to Tarong Power Station	June 2024	<a href="#">Section 5.7.7</a>
			Partial network support – replace the functionality of one of the existing transformers on a continuous basis		
Redbank Plains 110kV primary plant and 110/11kV transformers replacement	\$8m	Moreton	Provide support to the 11kV network of up to 25MW and up to 400MWh per day	June 2024	<a href="#">Section 5.7.10</a>

Notes:

- (1) Operational works, such as asset retirements, do not form part of Powerlink's capital expenditure budget. However material operational costs, which are required to meet the scope of a network option, are included in the overall cost of that network option as part of the RIT-T cost-benefit analysis. Therefore, in the RIT-T analysis, the total cost of the proposed option will include an additional \$10 million to account for operational works for the retirement of the transmission line.
- (2) More generally, TAPR template data associated with emerging constraints which may require future capital expenditure, including potential projects which fall below the RIT-T cost threshold, is available on Powerlink's website (refer to Appendix B, in particular transmission connection points and transmission line segments data templates).



## Appendix G Glossary

ABS	Australian Bureau of Statistics	GPS	Generator Performance Standards
AEMC	Australian Energy Market Commission	GSP	Gross State Product
AEMO	Australian Energy Market Operator	GWh	Gigawatt hour
AER	Australian Energy Regulator	HV	High Voltage
ARENA	Australian Renewable Energy Agency	ISP	Integrated System Plan
BSL	Boyne Smelters Limited	IUSA	Identified User Shared Assets
CAA	Connection and Access Agreement	JPB	Jurisdictional Planning Body
CBD	Central Business District	kA	Kiloampere
COVID-19	Coronavirus disease 2019	kV	Kilovoltage
CPI	Consumer Price Index	LTTW	Lightning Trip Time Window
CQ	Central Queensland	MLF	Marginal Loss Factor
CQ-SQ	Central Queensland to South Queensland	MVA	Megavolt Ampere
CQ-NQ	Central Queensland to North Queensland	MVA <sub>r</sub>	Megavolt Ampere reactive
CSG	Coal seam gas	MW	Megawatt
DCA	Dedicated Connection Assets	MWh	Megawatt hour
DER	Disributed Energy Resources	NEM	National Electricity Market
DNRME	Department of Natural Resources, Mines and Energy	NEMDE	National Electricity Market Dispatch Engine
DNSP	Distribution Network Service Provider	NER	National Electricity Rules
DSM	Demand side management	NNESR	Non-network Engagement Stakeholder Register
EFCS	Emergency Frequency Control Schemes	NIEIR	National Institute of Economic and Industry Research
EII	Energy Infrastructure Investments	NSP	Network Service Provider
ENA	Energy Networks Australia	NSCAS	Network Support and Control Ancillary Service
EMT-type	Eletromagnetic Transient-type	NTNDP	National Transmission Network Development Plan
EOI	Expresession of interest	NSW	New South Wales
ESOO	Electricity Statement of Opportunity	NQ	North Queensland
EV	Electric vehicles	OFGS	Over Frequency Generation Shedding
FIA	Full Impact Assessment	PACR	Project Assessment Conclusion Report
FIT	Feed-in tariff	PADR	Project Assessment Draft Report
FNQ	Far North Queensland	PIA	Preliminary impact assessment
GCG	Generation Capacity Guide	PoE	Probability of Exceedance
GFI	Grid forming inverter		

Appendix G - Glossary (*continued*)

PS	Power Station
PSFRR	Power System Frequency Risk Review
PV	Photovoltaic
PVNSG	Photovoltaic non-scheduled generation
QAL	Queensland Alumina Limited
QER	Queensland Energy Regulator
QHES	Queensland Household Energy Survey
QNI	Queensland/New South Wales Interconnector
QRET	Queensland Renewable Energy Target
REZ	Renewable Energy Zone
RIT-D	Regulatory Investment Test for Distribution
RIT-T	Regulatory Investment Test for Transmission
SCR	Short Circuit Ratio
SDA	State Development Area
SEQ	South East Queensland
SPS	Special Protection Scheme
STATCOM	Static Synchronous Compensator
SVC	Static VAr Compensator
SWQ	South West Queensland
SynCon	Synchronous Condenser
TAPR	Transmission Annual Planning Report
TGCP	TAPR Guideline Connection Point
TGTL	TAPR Guideline Transmission Line
TNSP	Transmission Network Service Provider
UFLS	Under Frequency Load Shed
UVLS	Under Voltage Load Shed
VCR	Value of Customer Reliability
VRE	Variable renewable energy
VTL	Virtual transmission line
WAMPAC	Wide area monitoring and control

# Contact us

Registered office 33 Harold St Virginia  
Queensland 4014 Australia  
ABN 82 078 849 233

Postal address PO Box 1193 Virginia  
Queensland 4014 Australia

Telephone +61 7 3860 2111  
(during business hours)

Email [pqenquiries@powerlink.com.au](mailto:pqenquiries@powerlink.com.au)

Website [www.powerlink.com.au](http://www.powerlink.com.au)

Social media    

