

Appendix 11.1: Transmission pricing methodology 2019-24

Regulatory proposal for the ACT electricity distribution network 2019-24
January 2018

Table of contents

List of figures	v
List of tables	v
Overview	vii
1 Introduction	1
1.1 Revisions to the <i>pricing methodology</i>	1
1.2 Interpretation	1
1.3 <i>Prescribed transmission services</i>	1
1.4 Rules requirements	2
2 Transmission Pricing Methodology Guideline requirements	3
2.1 <i>Co-ordinating Network Service Provider</i>	3
2.2 Summary of this Proposal	3
3 Proposed <i>transmission pricing methodology</i>	4
3.1 Arrangements applicable to Evoenergy for the 2019-24 regulatory control period	4
3.2 Calculating the Aggregate Annual Revenue Requirement	5
3.3 Categorising exit, entry, shared and common service assets	5
3.4 Calculation of the <i>Annual service revenue requirement</i> for each category of service	6
3.5 Allocation of the <i>ASRR</i> to specific assets and <i>transmission network connection points</i>	8
3.6 Provision for relaxation of TUoS locational side constraints	12
3.7 <i>Transmission</i> prices and charges	12
3.8 Contract demand charge	12
3.9 Setting of TUoS locational prices between annual price publications	12
4 Billing arrangements	13
4.1 Billing for <i>prescribed transmission services</i>	13
4.2 Payments between <i>Transmission Network Service Provider s</i>	13
5 <i>Prudential requirements</i>	13
5.1 <i>Prudential requirements</i> for <i>prescribed transmission services</i>	13
5.2 Capital contribution or prepayment for a specific asset	14

6	Prudent discounts	14
7	Monitoring and compliance	14
8	Additional information requirements	15
9	Confidential elements of <i>pricing methodology</i>	15
	Appendix 1: Details of cost allocation process	16

List of figures

Figure 1	Illustration of network branches	21
Figure 2	Example 1 substation layout	21
Figure 3	Example 1 stand-alone <i>prescribed TUoS services</i>	22
Figure 4	Example 1 stand-alone prescribed common services	22
Figure 5	Example 2 substation layout	23
Figure 6	Example 2 stand-alone <i>prescribed TUoS services</i>	24
Figure 7	Example 2 stand-alone prescribed common services	24
Figure 8	Example 3 substation layout	25
Figure 9	Example 3 stand-alone <i>prescribed TUoS services</i>	26

List of tables

Figure 1	Illustration of network branches	21
Figure 2	Example 1 substation layout	21
Figure 3	Example 1 stand-alone <i>prescribed TUoS services</i>	22
Figure 4	Example 1 stand-alone prescribed common services	22
Figure 5	Example 2 substation layout	23
Figure 6	Example 2 stand-alone <i>prescribed TUoS services</i>	24
Figure 7	Example 2 stand-alone prescribed common services	24
Figure 8	Example 3 substation layout	25
Figure 9	Example 3 stand-alone <i>prescribed TUoS services</i>	26

Overview

This document sets out Evoenergy's approach to the pricing of its dual-function assets - that is, those that perform a *transmission* function in the National Electricity Market (NEM).¹

To cater for increasing demand for electricity in the ACT and the south-eastern *region* of NSW, the high voltage *transmission system* that services these areas has been augmented. TransGrid established a 330/132 kV substation at Williamsdale in February 2012, providing a second high-capacity supply to the south-eastern extremity of the ACT, to supplement the existing Canberra 330/132 kV substation to the north of the ACT.

The resulting supply arrangement makes use of the capability of both TransGrid's and Evoenergy's networks, in order to minimise overall costs. Significant portions of Evoenergy's 132 kV network in the ACT perform a *transmission* function, by operating in parallel with and providing support to TransGrid's 330 kV network. These Evoenergy assets are termed *dual function assets* and constitute a material proportion of Evoenergy's asset base.

As a consequence of this supply arrangement, the Australian Energy Regulator (AER) determined that *transmission* pricing arrangements are to continue to apply to Evoenergy's *dual function assets* throughout the 2019-24 *regulatory control period*.

This document sets out the methodology that Evoenergy has developed for its *transmission* pricing and is a requirement of the National Electricity Rules (the Rules).

¹ Evoenergy was formerly known as ActewAGL *Distribution*.

1 Introduction

Evoenergy provides the following network services:

- *distribution services* within the ACT; and
- *transmission services* to the south-eastern *region* of NSW.

The pricing of *distribution services* is described in the *pricing proposal* that Evoenergy must submit to the AER under Chapter 6.18 of the Rules.

This document outlines Evoenergy's proposed *transmission pricing methodology*.

This *pricing methodology* directly reflects the *pricing principles* for *prescribed transmission services* set out in clause 6A.23 of the National Electricity Rules.² The standardised approach described in this document has been developed to conform with the steps and sequence set out in the Rules.

This *pricing methodology* is proposed to apply from 1 July 2019 to 30 June 2024.

1.1 Revisions to the *pricing methodology*

TransGrid is the *Co-ordinating Network Service Provider* for the NSW *region*. The AER is currently in the process of determining TransGrid's revenues for the 2018-23 *regulatory control period* and will make its final *determination* on 30 April 2018. As part of its *regulatory proposal* in January 2017, TransGrid submitted a proposed *pricing methodology*.³

The AER made its draft determination for TransGrid in September 2017 and approved TransGrid's proposed *pricing methodology*.⁴ This Evoenergy *pricing methodology* includes aspects of TransGrid's and has been updated to ensure consistency with it.

1.2 Interpretation

In this proposed *transmission pricing methodology*, italicised terms have the meaning given to them in the Australian Energy Regulator's (AER's) *transmission pricing methodology guidelines* or in the Rules.⁵

1.3 *Prescribed transmission services*

Evoenergy's proposed *transmission pricing methodology* relates to the provision of *prescribed transmission services*. These services are provided by *dual function assets*, which operate in parallel, and provide support to, TransGrid's higher voltage *transmission network*. The services provided by these Evoenergy assets include:

² AEMC, *National Electricity Rules Version 103*, 1 December 2017.

³ TransGrid, *Pricing methodology 2018/19 – 2022/23*, October 2016.

⁴ AER, *Draft Decision - TransGrid transmission determination 2018 to 2023 - Attachment 12 - Pricing methodology*, September 2017, p. 12-6.

⁵ AER, *Final - Electricity Transmission Network Service Providers Pricing methodology guidelines*, July 2014.

- Shared *transmission services* provided to *Network Service Providers* (*prescribed TUoS services*);
- Connection services provided to connect Evoenergy's *distribution network* to the *transmission network* (*prescribed exit services*); and
- Services required under the Rules or in accordance with jurisdictional electricity legislation that are necessary to ensure the integrity of the *transmission network*, including through the maintenance of power system security and assisting in the planning of the power system (*prescribed common transmission services*).

This proposed *transmission pricing methodology* does not relate to the provision of *negotiated transmission services* (deemed to be *negotiated distribution services* under clause 6.24.2(c) of the Rules) that may be provided by Evoenergy.

1.4 Rules requirements

Clause 6A.24.1(b) of the Rules states that:

- (b) A *pricing methodology* is a methodology, formula, process or approach that, when applied by a *Transmission Network Service Provider* (or a *Co-ordinating Network Service Provider* on behalf of *Transmission Network Service Providers* within a region);
- (1) allocates the *aggregate annual revenue requirement* for *prescribed transmission services* provided by the *Transmission Network Service Provider* to each category of *prescribed transmission services*;
 - (2) provides for the manner and sequence of adjustments to the *annual service revenue requirement*;
 - (3) allocates the *annual service revenue requirement* to *transmission network connection points* (other than *connection points* of any *Market Network Service Provider*); and
 - (4) determines the structure and recovery of prices for each *category of prescribed transmission services* under 6A.23.4(a).

The Rules also require that the *transmission pricing methodology* satisfy principles and guidelines established by the Rules. In particular, clause 6A.10.1(e) of the Rules requires that the proposed *transmission pricing methodology* must:

- (1) give effect to and be consistent with the *Pricing principles* for *prescribed transmission services* (that is to say, the principles set out in rule 6A.23); and
- (2) comply with the requirements of, and contain or be accompanied by such information as is required by, the *transmission pricing methodology guidelines* made for that purpose under rule 6A.25.

In July 2014, the AER issued amended *Pricing methodology guidelines*, pursuant to clause 6A.25 of the Rules.

2 Transmission Pricing Methodology Guideline requirements

2.1 *Co-ordinating Network Service Provider*

In accordance with clause 6A.29.1 of the Rules, TransGrid is the *Co-ordinating Network Service Provider* for NSW. As at June 2019, for the purposes of *transmission pricing* there are expected to be five TNSPs covering NSW and the ACT *region* of the National Electricity Market. Evoenergy is required to annually provide TransGrid with a revised model of Evoenergy's *transmission network*, with the approved AARR for its *transmission system* already allocated in accordance with this *transmission pricing proposal*. Evoenergy is also required to provide any other information reasonably required by TransGrid to ensure the proper calculation of *transmission prices* in New South Wales. The calculation of the *postage stamp* rates which form part of *transmission prices* referred to in the AER Guidelines at 2.1(h) are calculated by the *Co-ordinating TNSP*, TransGrid.

Note that there are currently no prudent discounts to Evoenergy customers referred to in the AER Guidelines at 2.1(k).

2.2 Summary of this Proposal

The AER's *transmission pricing methodology guidelines* are issued pursuant to the Rules. They specify:

- The information that is to accompany a proposed *transmission pricing methodology*,
- Permitted pricing structures for the recovery of the locational component of *prescribed TUoS services*;
- Permitted *postage stamp* pricing structures for *prescribed common transmission services* and the recovery of the adjusted non-locational component of *prescribed TUoS services*;
- The types of *transmission system* assets that are directly attributable to each category of *prescribed transmission services*; and
- Those parts of a proposed *transmission pricing methodology*, or the information accompanying it that will not be publicly disclosed without the consent of the TNSP.

Evoenergy is an *appointing provider* of *transmission services* in NSW. As a consequence, the scope of this *transmission pricing methodology* is limited to:

- Calculation of the Annual Aggregate Revenue Requirement for each regulatory year of the regulatory control period (section 3.2);
- Proposing a methodology to determine whether assets fall in to the categories of exit, entry, shared or common service (section 3.3 and Appendix 1);
- Detail of how the priority ordering approach of clause 6A.23.2(d) of the Rules has been implemented, including three worked examples (Appendix 1);
- Allocating the AARR to exit, entry, shared and common service asset classes using an attributable cost share method, to determine an Annual Service Revenue Requirement (ASRR) for each asset class (section 3.4);

- Allocating the ASRR of each asset class to the specific assets within that asset class (section 3.5);
- Describing how asset costs which are associated with prescribed entry services and prescribed exit services at a connection point, which may be attributable to multiple Transmission Network Users, will be allocated (section 3.5.4);
- Billing arrangements for direct connected Transmission Customers (section 4);
- Management of prudential requirements and prudent discounts for new or existing connections to the Evoenergy transmission network (section 6); and
- Detail of how Evoenergy intends to monitor and develop records of its compliance with its approved transmission pricing methodology, the pricing principles for prescribed transmission services (clause 6A.23) and part J of the Rules (section 7).

Elements of the *pricing methodology* required by the AER guidelines and National Electricity Rules that are carried out by TransGrid on behalf of Evoenergy are:

- Any adjustments required to be made to the locational component of the *ASRR* as required by the Rules.⁶
- Any adjustments required to be made to the pre-adjusted non-locational component of the *ASRR* as required in the Rules.⁷
- Allocation of the locational component of *prescribed TUoS services* to *transmission connection points*.
- Establishing the structure and price for common service, general, and locational charges at each of Evoenergy's *transmission connection points*.⁸

3 Proposed *transmission pricing methodology*

3.1 Arrangements applicable to Evoenergy for the 2019-24 regulatory control period

The AER has commenced the process of making a determination on Evoenergy's revenues for the *regulatory control period* from 1 July 2019 to 30 June 2024.

In July 2017, the AER determined under clause 6.25(b) of the Rules that Evoenergy's *dual function assets* will remain subject to the Rules provisions on *transmission pricing* during the 2019-24 *regulatory control period*.⁹

Clause 6.26 of the Rules establishes that the *transmission pricing* arrangements in Part J of Chapter 6A apply to Evoenergy's *dual function assets*. Clause 6A.24.2 requires Evoenergy to publish a *pricing methodology* for its *dual function assets*.

⁶ Rules, clause 6A.23(c)(1).

⁷ Rules, clause 6A.23(c)(2).

⁸ That is, Evoenergy transmission connection points that supply Evoenergy's distribution network, rather than the TransGrid connection points that supply Evoenergy's transmission and distribution networks.

⁹ AER, *Framework and approach - ActewAGL - Regulatory control period commencing 1 July 2019*, July 2017, p.72.

3.2 Calculating the Aggregate Annual Revenue Requirement

Evoenergy owns both *distribution* assets and *dual function* assets, the latter providing *transmission standard control services*.

The portion of the *aggregate annual revenue requirement* relevant to *transmission standard control services* is established by the AER under clause 6.26(b)(1). To arrive at the AARR for *transmission standard control services* for the purposes of Part J of Chapter 6A, the *maximum allowed revenue* is adjusted in accordance with:

- (1) Rules clause 6.6 (relating to adjustments after the making of a *building block determination*);
- (2) Rules clause 6.13 (relating to revocation of a determination); and
- (3) Subtracting the operating and maintenance costs expected to be incurred in the provision of *prescribed common transmission services*, in accordance with clause 6A.22.1.

For the purposes of determining the AARR for *transmission* pricing, Evoenergy has complied with these requirements. Evoenergy has derived the costs referred to in (3) above from budget projections, including:

- Network switching and operations;
- Administration and management of the business;
- Network planning and development; and
- General overheads.

3.3 Categorising exit, entry, shared and common service assets

Evoenergy's AARR for *prescribed transmission services* is recovered from *transmission* charges for the following categories of *transmission service*:

- *Prescribed exit services*, which include assets that are fully dedicated to serving a *Transmission Customer* or group of *Transmission Customers* at a single *connection point* and: (a) are deemed prescribed by virtue of the operation of clause 11.6.11 of the Rules; or (b) are provided to *Network Service Provider* at the boundary of the prescribed *transmission network*;
- *Prescribed transmission use of system (TUoS) services* which include assets that are shared to a greater or lesser extent by all users across the *transmission system* and are not *prescribed common transmission services*, *prescribed entry services* or *prescribed exit services*; and
- *Prescribed common transmission services*, which are services that benefit all *Transmission Customers* and cannot be reasonably allocated on a locational basis.

At this time, Evoenergy does not have any assets providing *prescribed entry services* to a *transmission* connected generator. However, this proposal outlines Evoenergy's proposed methodology with respect to the allocation of these services in anticipation that such a service may be required. *Prescribed entry services* include those assets that are fully dedicated to serving a Generator or group of Generators at a single *connection point*.

The first step in calculating prescribed *transmission service* prices is to classify each asset utilised in the provision of *prescribed transmission services* into one of the above

categories of service. The delineation between the assets that provide *prescribed entry services, prescribed exit services, prescribed TUoS services and prescribed common transmission services* is set out in clause 2.4 of the AER's *transmission pricing methodology guidelines*.

The cost allocation process assigns the optimised replacement cost (ORC)¹⁰ of all prescribed assets to either *prescribed common transmission services* (assets that benefit all *Transmission Customers*) or individual network branches (*transmission* lines and transformers). Each branch is then defined as entry, exit or shared network. This process of cost allocation is explained in more detail in Appendix 1.

3.4 Calculation of the *Annual service revenue requirement* for each category of service

The second step in calculating prescribed *transmission service* prices is calculation of the attributable cost share for each category of service, in accordance with clause 6A.22.3 of the Rules. The attributable cost share is the ratio of:

- The costs of the *transmission system* assets directly attributable to the provision of that category of *prescribed transmission services* (as determined in 3.3); to
- The total costs of all the TNSP's *transmission system* assets directly attributable to the provision of *prescribed transmission services* (as determined in 3.3).

For example, assume the ORCs of prescribed services assets have been allocated to the applicable categories of *prescribed transmission services* as shown in Table 1.

Table 1 Costs allocated to categories of *prescribed transmission services* (indicative 2018/19)

Category	ORC \$'000
Exit service	221,000
Entry service	0
TUoS service	147,000
Common Service	5,000
Total	373,000

The attributable cost shares are calculated as:

$$\begin{aligned}
 \text{Attributable Cost Share EXIT} &= \text{ORC EXIT} / \text{ORC TOTAL} \\
 &= \$347,000 / \$636,000 \\
 &= 0.55
 \end{aligned}$$

¹⁰ Consistent with clause 6A.22.3(b) of the Rules

The attributable cost shares of the other categories are calculated in the same manner, as shown in Table 2.

Table 2 Attributable Cost Shares (indicative 2018/19)

Category	ORC \$'000	Attributable Cost Share
Exit service	221,000	59%
Entry service	0	-
TUoS service	147,000	39%
Common Service	5,000	1%
Total	373,000	100%

The third step in calculating prescribed *transmission service* prices is to allocate the *AARR* to each category of prescribed *transmission service* in accordance with the attributable cost share for each such category of services.

This allocation results in the *annual service revenue requirement (ASRR)* for that category of services.

Assuming an *AARR* of \$23.8 M and applying the attributable cost shares determined above the *ASRR* for each category of prescribed services is calculated as:

$$\begin{aligned}
 ASRR_{\text{EXIT}} &= AARR \times \text{Attributable Cost Share}_{\text{EXIT}} \\
 &= \$23,800,000 \times 59\% \\
 &= \$14,600,000
 \end{aligned}$$

The *ASRRs* of the other categories are calculated in the same manner, as shown in Table 3.

Table 3 Attributable Cost Shares (indicative 2018/19)

Category	Attributable Cost Share	Annual Service Revenue Requirement (<i>ASRR</i>) \$'000
Exit service	59%	14,600
Entry service	-	-
TUoS service	39%	8,800
Common Service	1%	300
Total	100%	23,800

3.5 Allocation of the ASRR to specific assets and *transmission network connection points*

The fourth step in calculating prescribed *transmission service* prices is to allocate the ASRR for *prescribed entry services*, *prescribed exit services* and *prescribed TUoS services* to each *transmission network connection point* in accordance with the principles of clause 6A.23.3 of the Rules.

3.5.1 Prescribed entry services

Evoenergy does not currently have any *prescribed entry services*. This hypothetical example indicates how the cost allocation for these services would be treated. The whole of the ASRR for *prescribed entry services* is allocated to *transmission network connection points* in accordance with the attributable *connection point* cost share for *prescribed entry services* that are provided at that *connection point*.

The attributable *connection point* cost share for *prescribed entry services* is the ratio of the costs of the *transmission system* assets directly attributable to the provision of *prescribed entry services* at that *transmission network connection point* to the total costs of all the TNSP's *transmission system* assets directly attributable to the provision of *prescribed entry services*.

For example, consider two hypothetical generators, Gen 1 and Gen 2, that receive *prescribed entry services* and the cost allocation methodology had allocated the ORCs of assets (in \$'000) directly attributable to entry services to them as follows:

$$\begin{aligned}
 \text{Attributable Connection Point Cost Share}_{\text{GEN AI}} &= \text{ORC}_{\text{GEN AI}} / \text{ORC}_{\text{ENTRY}} \\
 &= \$1,000 / \$3,000 \\
 &= 0.333
 \end{aligned}$$

The ORC shares are shown in Table 4.

Table 4 Prescribed entry services ORCs (hypothetical example)

Entry	ORC \$'000
Gen 1	1,000
Gen 2	2,000
Total ORC of prescribed entry assets	3,000

The attributable *connection point* cost shares of the generators are calculated as shown in Table 5.

Table 5 Attributable *connection point* cost shares (hypothetical example)

Entry	ORC \$'000	Attributable connection point cost share
Gen 1	1,000	0.333
Gen 2	2,000	0.667
Total	3,000	1.000

The *ASRR* of \$100,000 allocated to the Gen AI *transmission network connection point* is calculated as follows:

$$\begin{aligned}
 ASRR_{\text{GEN AI}} &= ASRR_{\text{ENTRY}} \times \text{Attributable connection point cost share}_{\text{GEN AI}} \\
 &= \$100,000 \times 0.333 \\
 &= \$33,333
 \end{aligned}$$

The *ASRR* of the generator *connection points* is shown in Table 6.

Table 6 *Connection point ASRRs* (Entry) (hypothetical example)

Entry	ORC \$'000	Attributable connection point cost share	Connection point <i>ASRR</i>
Gen 1	1,000	0.333	33,333
Gen 2	2,000	0.667	66,667
Total	3,000	1.000	100,000

The *ASRR* related to the entry assets for each generator is recovered via a daily fixed charge. For example, Gen AI will be charged a daily rate of:

$$\begin{aligned}
 \text{Gen 1 Fixed Charge} &= \$33,333/365 \text{ days} \\
 &= \$91.32/\text{day for the relevant financial year}
 \end{aligned}$$

No other charges will be applied to generators, as the Rules specify that the *transmission network* is allocated to loads, rather than generation. Common services and TUoS services are therefore allocated to loads.

3.5.2 Prescribed exit services

The whole of the ASRR for *prescribed exit services* is allocated to *transmission network connection points* in accordance with the attributable *connection point* cost share for *prescribed exit services* that are provided by the TNSP at that *connection point*.

The attributable *connection point* cost share for *prescribed exit services* is the ratio of the costs of the *transmission system* assets directly attributable to the provision of *prescribed exit services* at that *transmission network connection point* to the total costs of all the *transmission system* assets directly attributable to the provision of *prescribed exit services*.

The ASRRs of the prescribed exit *connection points* are calculated in the same manner as for the entry *connection points*, with a total ASRR of \$9.0 M.

Table 7 Connection point ASRRs (Exit) (hypothetical example)

Exit	ORC \$'000	Attributable connection point cost share	Connection point ASRR \$'000
Load A	10,000	0.333	3,000
Load B	15,000	0.500	4,500
Load C	5,000	0.167	1,500
Total	30,000	1.000	9,000

The ASRR related to the exit assets for each load is recovered via a daily fixed charge. For example, Load A will be charged a daily rate of:

$$\begin{aligned} \text{Load A Fixed Charge} &= \$3,000,000/365 \text{ days}^{11} \\ &= \$818.18 \text{ per day for the relevant financial year.} \end{aligned}$$

Locational charges, TUoS general charges and common service charges will also apply to Load A, and are calculated by TransGrid as the Co-ordinating TNSP appointed by Evoenergy.

3.5.3 Prescribed Transmission Use of System (TUoS) services

The prescribed TUoS (shared network) services ASRR is recovered from:

- *Prescribed TUoS services* (locational component); and
- *Prescribed TUoS services* (the pre-adjusted non-locational component).

Clause 6A.23.3(c)(2) of the Rules requires that the pre-adjusted non-locational component be adjusted as follows, by:

adding or subtracting any amount for settlements residue (not being any auction amount referred to in subparagraph (b)(1), but including any amount of settlements residue due to intra - regional loss factors)

¹¹ 366 days is used for this calculation in a leap year.

estimated to be receivable by or payable to the Transmission Network Service Provider in accordance with clause 3.6.5(a)(3)

In NSW, TransGrid as the co-ordinating TNSP and ensures compliance with this requirement, since Evoenergy is not a direct recipient of auction amounts. TransGrid makes relevant adjustments to account for auction amounts in its *pricing methodology*, consistent with clause 6A.23.3(c)(2). Please refer to TransGrid's *transmission pricing methodology* with respect to compliance with this clause.

Allocation of the locational component of *prescribed TUoS services* is carried out by TransGrid using the methodology approved by the AER, which assigns a proportion of shared network costs to individual customer *connection points*. Details of this calculation can be found in TransGrid's *transmission pricing proposal*.

This allocation of the locational component of *prescribed TUoS services* by TransGrid requires data for Evoenergy's *transmission network*, its costs and utilisation.

The remainder of the *ASRR* (the pre-adjusted non-locational component) is to be adjusted:

- By subtracting the amount (if any) referred to in clause 6A.23.3(e) of the Rules;
- By subtracting or adding any remaining settlements residue (not being settlements residue referred to in the determination of the locational component but including the portion of settlements residue due to intra-*regional* loss factors) which is expected to be distributed or recovered (as the case may be) to or from the TNSP in accordance with clause 3.6.5(a) of the Rules;
- For any over-recovery amount or under-recovery amount from previous years;
- For any amount arising as a result of the application of clause 6A.23.4(h) and (i) of the Rules; and
- For any amount arising as a result of the application of prudent discounts in accordance with clause 6A.26.1(d)-(g) of the Rules.

These adjustments are carried out by TransGrid as the Co-ordinating TNSP in NSW. Evoenergy provides advice to TransGrid of any expected under-recovery or over-recovery amount from previous years to be used by TransGrid in setting prices each year.

3.5.4 Costs that could be allocated to more than one category of service

Evoenergy allocates substation costs that are directly attributable to entry, exit, common and TUoS services and then allocates the residual costs, known as substation local costs, to entry, exit and TUoS services on the basis of the number of pricing branches (*transmission* lines and transformers) connected to that substation.

Clause 6A.23.2(d) of the Rules has a priority ordering concept for the allocation of those costs which could be attributable to more than one category of *prescribed transmission services*.

The substation local costs are allocated to the various prescribed services in accordance with the provisions of clause 6A.23.2(d) of the Rules having regard to the stand-alone costs associated with the provision of *prescribed TUoS services* and *prescribed common transmission services* with the remainder being allocated to prescribed entry and *prescribed exit services*.

Details of Evoenergy's application of priority ordering can be found in Appendix 1.

3.6 Provision for relaxation of TUoS locational side constraints

The implementation of clause 6A.23.4(g) of the Rules allows for the relaxation of the 2% side constraint for material changes in *connection point* load or renegotiation of connection agreements, subject to AER approval.

In the event that a *Transmission Customer* requests a material increase in demand at an existing *connection point*, Evoenergy, together with TransGrid, as the Co-ordinating TNSP in NSW, will seek approval from the AER to set the prescribed TUoS - locational price as intended by clause 6A.23.4(g) of the Rules.

3.7 Transmission prices and charges

Calculation of prices for all *prescribed transmission services* in NSW is carried out by TransGrid as the Co-ordinating TNSP in NSW. Please refer to TransGrid's *pricing methodology* for the calculation of prices for Evoenergy's *transmission network*. TransGrid receives Evoenergy's *transmission* models with all assets allocated to the relevant asset classes and a portion of the *AARR* allocated to give the *ASRR* for each class. Assets within each asset class have already been allocated a portion of the *ASRR* for that class in accordance with this *pricing methodology*.

3.8 Contract demand charge

To the extent that it is permitted by TransGrid's *Pricing methodology*, Evoenergy is able to nominate locations on its *transmission network* where an excess demand charge is to apply. Evoenergy would nominate to TransGrid the particular locations of Evoenergy's *transmission connection points* (a *connection point* direct to TransGrid or one that connects Evoenergy's *distribution network* to its *transmission network*) where excess demand charging is to apply. Evoenergy would propose an agreed maximum demand for this *connection point*, and if Evoenergy's maximum demand exceeded the contract agreed maximum demand level at any time during the financial year then an Excess Demand Charge determined by TransGrid would apply.

Evoenergy has not to date nominated any locations on the *transmission network* where an excess demand charge would apply but may do so during the 2019-24 *regulatory control period*.

3.9 Setting of TUoS locational prices between annual price publications

In the event that Evoenergy requires a TUoS locational price at a new *connection point* or at a connection where the load has changed significantly after prescribed TUoS service locational prices have been determined and published, an interim price, not subject to the side constraints of clause 6A.23.4(f) of the Rules, will be determined by TransGrid as the co-ordinating TNSP in NSW. This will be calculated using the prevailing pricing models with demands estimated in a manner consistent with clause 2.2(f) of the *transmission pricing methodology guidelines*.

A price subject to the side constraints of clause 6A.23.4(f) of the Rules will be determined and published by TransGrid, as the *Co-ordinating Network Service Provider* in NSW and the ACT, at the following annual price determination.

4 Billing arrangements

4.1 Billing for *prescribed transmission services*

Consistent with the clause 6A.27.1 of the Rules, Evoenergy will calculate the *transmission service* charges payable by Transmission Network Users connected to the Evoenergy *transmission network*, in accordance with the *transmission service* prices published under clause 6A.24.2 as calculated by TransGrid. The prices calculated by TransGrid that are relevant to the Evoenergy *transmission network* are published on the Evoenergy website.

Where charges are determined for *prescribed transmission services* from metering data, these charges will be based on kW or kWh obtained from the metering data managed by AEMO.

Evoenergy will issue bills to Transmission Network Users for *prescribed transmission services* which satisfy or exceed the minimum information requirements specified in clause 27.2 of the Rules on a monthly basis or as agreed between the parties.

Consistent with clause 6A.27.3 of the Rules, a Transmission Network User must pay charges for *prescribed transmission services* properly charged to it and billed in accordance with the *transmission pricing methodology* of the relevant *Transmission Network Service Provider* by the date specified on the bill.

4.2 Payments between *Transmission Network Service Provider s*

Consistent with clause 6A.27.4 of the Rules, TransGrid is the *Co-ordinating Network Service Provider* in NSW and the ACT under 6A.29.1 of the Rules and will pay to each other relevant *Transmission Network Service Provider* the revenue which is estimated to be collected during the following year by the first provider as charges for *prescribed transmission services* for the use of *transmission systems* owned by those other *Transmission Network Service Provider*.

Such payments will be determined by TransGrid, as the *Co-ordinating Network Service Provider* for the region.

Financial transfers payable under clause 6A.27.4 of the Rules will be paid in equal monthly instalments or as documented in revenue collection agreements *negotiated* between the parties.

5 Prudential requirements

5.1 Prudential requirements for *prescribed transmission services*

Consistent with clause 6A.28.1 of the Rules, Evoenergy may require a Transmission Network User to establish *prudential requirements* for *either transmission connection services* or *transmission use of system services* or both. These *prudential requirements* may take the form of, but need not be limited to, capital contributions, pre-payments or financial guarantees.

The requirements for such *prudential requirements* will be *negotiated* between the parties and specified in the applicable connection agreement.

5.2 Capital contribution or prepayment for a specific asset

Consistent with clause 6A.28.2 of the Rules, where Evoenergy is required to construct or acquire specific assets to provide prescribed connection services or *prescribed TUoS services* to a Transmission Network User, Evoenergy may require that user to make a capital contribution or prepayment for all or part of the cost of the new assets installed.

In the event that a capital contribution is required, any contribution made will be taken into account in the determination of prescribed *transmission service* prices applicable to that user by way of a proportionate reduction in the ORC of the asset(s) used for the allocation of prescribed charges or as *negotiated* between the parties.

In the event that a prepayment is required any prepayment made will be taken into account in the determination of prescribed *transmission service* prices applicable to that user in a manner to be *negotiated* between the parties.

The treatment of such a capital contribution or prepayment for the purposes of a revenue determination will be in accordance with the relevant provisions of the Rules.

Evoenergy may require a bank guarantee from a *Transmission Customer*, to cover the financial year of a *transmission* investment made by Evoenergy for the customer. Bank guarantees will only be relevant in cases where such investments relate to the construction of prescribed *transmission* assets. Such guarantees will be made in agreement with the customer and hold funds as security for Evoenergy in the event that the customer does not provide a satisfactory income stream through payment for TUoS charges over an agreed period of time.

6 Prudent discounts

Evoenergy is required to provide information to TransGrid in relation to prudent discounts relating to Evoenergy's *Transmission Customers*. TransGrid would adjust, in accordance with rule 6A.26.1(d)-(g), the non-locational component of the *ASRR* for *prescribed TUoS services* for the amount of any anticipated under-recovery arising from prudent discounts applied.

Evoenergy currently has no prudent discount arrangements with any *Transmission Customers*.

7 Monitoring and compliance

As a regulated business Evoenergy is required to maintain compliance monitoring and reporting systems to demonstrate compliance with its Distribution Licence, Revenue Determination, the National Electricity Rules and other statutory obligations.

In order to monitor and maintain records of its compliance with its approved *transmission pricing methodology*, the *pricing principles* for *prescribed transmission services*, and part J of the Rules Evoenergy proposes to:

- Maintain the specific obligations arising from part J of the Rules in its compliance management system;
- Maintain electronic records of the annual calculation of prescribed *transmission* prices and supporting information; and

- Periodically subject its *transmission* pricing models and processes to functional audit by suitably qualified persons.

8 Additional information requirements

Evoenergy does not consider transitional arrangements necessary as a result of the implementation of this proposed *transmission pricing methodology*. Evoenergy does not have any relevant derogations in accordance with chapter 9 of the Rules, nor are there any applicable transitional arrangements arising from chapter 11 of the Rules relevant to this proposed *transmission pricing methodology*.

9 Confidential elements of *pricing methodology*

This *pricing methodology* is not considered confidential by Evoenergy.

Appendix 1: Details of cost allocation process

A detailed cost allocation process is used to assign the optimised replacement cost (ORC) of all prescribed service assets to either common service (assets that benefit all *Transmission Customers*), network branches (*transmission* lines or transformers) and prescribed entry or *prescribed exit services* in a manner consistent with Section 2.4 of the AER's *transmission pricing methodology guidelines*.

The cost allocation process is summarised as follows.

Step 1: Initial Asset Cost Allocation

Assets and their ORCs are assigned to one of the following primary asset categories:

- Transmission lines;
- Transformers;
- Circuit breakers;
- Common service assets (communications, reactive support, office buildings etc.); and substation local assets (ancillary equipment, civil work, and establishment).

The following plant items are not separately identified in ORC values and are incorporated into the ORC of the associated primary items above:

- Bus work;
- Secondary systems including protection and instrument transformers.

Step 2: Allocation to Classes of Service

Assets are allocated to the classes of prescribed service in accordance with the provisions of Section 2.4 of the *transmission pricing methodology guidelines*. In the case of a circuit breaker, each has its replacement cost divided evenly between the branches to which it is directly attributable. Any circuit breaker that is not directly attributable to any branch together with substation local costs identified in Step 1 become subject to the priority ordering process.

In the case of a connection asset attributable to multiple network users, such as a transformer, serving multiple *Transmission Customers* at a *connection point* (which may provide prescribed entry and/or *prescribed exit services*) the cost of the shared connection asset will be allocated between the network users in accordance with a demand related allocation or as *negotiated* between the connected parties.

Step 3: Priority Ordering

In the case of those costs which would be attributable to more than one category of *prescribed transmission services*, specifically the substation local assets identified in Step 1 and those circuit breakers identified as substation local costs in Step 2, costs will be allocated in accordance with the provisions of clause 6A.23.2(d) of the Rules having regard to the stand alone costs associated with the provision of *prescribed TUoS services* and *prescribed common transmission services* with the remainder being allocated to prescribed entry and *prescribed exit services*. The implementation of the priority ordering process is detailed below.

Priority Ordering Methodology

Rules Requirement:

Clause 6A.23.2(d) of the Rules requires that:

Where, as a result of the application of the attributable cost share, a portion of the AARR would be attributable to more than one category of *prescribed transmission services*, that attributable cost share is to be adjusted and applied such that any costs of a *transmission system* asset that would otherwise be attributed to the provision of more than one category of *prescribed transmission services*, is allocated as follows:

- (1) to the provision of *prescribed TUoS services*, but only to the extent of the *stand-alone amount* for that category of *prescribed transmission services*;
- (2) if any portion of the costs of a *transmission system* asset is not allocated to *prescribed TUoS services*, under subparagraph (1), that portion is to be allocated to *prescribed common transmission services*, but only to the extent of the *stand-alone amount* for that category of *prescribed transmission services*;
- (3) if any portion of the costs of a *transmission system* asset is not attributed to *prescribed transmission services* under subparagraphs (1) and (2), that portion is to be attributed to *prescribed entry services* and *prescribed exit services*.

Stand-alone amount is defined as:

For a category of *prescribed transmission services*, the costs of a *transmission system* asset that would have been incurred had that *transmission system* asset been developed, exclusively to provide that category of *prescribed transmission services*.

AEMC Rule determination

In its rule determination, the AEMC provided the following guidance on the application of the priority ordering approach for the allocation of costs which can be attributed to more than one type of service ¹²:

“The Commission has maintained a priority ordering approach for the allocation of expenses or costs which can be attributed to more than one type of service. The cascading principle adopted by the Commission is based on the premise that users are seen to be the ‘cause’ of *transmission* investment. Therefore, costs should be first allocated to *prescribed transmission* use of system services on a stand-alone basis and then to *prescribed common transmission services*. Where a service/cost cannot justifiably be attributed to TUoS or common services it should be allocated to entry and exit services.”

In developing this methodology, Evoenergy has had regard for the following example in the rule determination ¹³:

Consider a substation costing \$22 M that was developed:

- partly in order to provide *Prescribed TUoS services*;

¹² Rule Determination for National Electricity Amendment (Pricing of *Prescribed transmission services*) Rule 2006, p5.

¹³ Ibid p. 37.

- partly in order to provide *Prescribed common transmission services*; and
- partly in order to provide *prescribed exit services*.

Then assume that had the substation been developed solely to provide *prescribed TUoS services*, it could have been much smaller and would have cost only \$10 M. Had the substation been developed solely in order to provide *prescribed common transmission services*, it would have cost \$5 M. Finally, had the substation been developed solely in order to provide *prescribed exit services*, it would have cost \$15 M.

The application of the principle would then lead to the \$30 M cost of the substation being attributed to *Prescribed Transmission service* categories as follows:

- \$10 M to the *prescribed TUoS services ASRR*;
- \$5 M to the *prescribed common services ASRR*; and
- The remaining \$7 M to the *prescribed exit service ASRR*.

Objective and General Approach

The proposed allocation methodology relies on the assumption that substation infrastructure and establishment costs are proportionate to the number of high voltage circuit breakers in the substation.

Based on this assumption, the appropriate allocator for substation infrastructure and establishment costs for a stand-alone arrangement is the ratio of the number of high voltage circuit breakers in the stand-alone arrangement to the number of high voltage circuit breakers in the whole substation.

Step 1: Branch Identification

Identify the branches, being the lines, transformers, major reactive devices and exits/entries in the substation which provide *prescribed TUoS*, *prescribed common transmission services* and exit or entry services, in the substation.

Step 2: Allocation of Circuit Breakers to Branches

For each high voltage circuit breaker in the substation identify the branches directly connected to it. Any circuit breaker that does not directly connect to a branch is excluded from allocation and all costs associated with it are added to the substation infrastructure and establishment cost.

Count the total number of circuit breakers directly connected to branches.

As a general rule, *Distribution network Service Provide (DNSPs)* are classified as a *prescribed exit service* while *Generators* are classified as a *prescribed entry service*. *Negotiated services* are not part of the regulated asset base and fall outside the priority ordering process detailed in clause 6A.23.2(d) of the Rules.

Step 3.1: Stand-alone arrangements for Prescribed TUoS

With reference to the number of lines providing *prescribed TUoS services* determine the number of circuit breakers required to provide *TUoS services* of an equivalent standard on a stand-alone basis. The stand-alone configuration is the simplest substation configuration (in the absence of development) had it been developed to provide a *prescribed TUoS service*. This may be done by way of a look up of typical stand-alone configurations.

Step 3.2: Stand-alone arrangements for Prescribed common transmission services

With reference to the number of lines providing *prescribed TUoS services* and the devices providing prescribed common service determine the number of circuit breakers required to provide *prescribed common transmission services* of an equivalent standard on a stand-alone basis. The stand-alone configuration is the simplest substation configuration (in the absence of development) had it been developed to provide a prescribed common service. This may be done by way of a look up of typical stand-alone configurations.

Step 4: Allocation of substation infrastructure and establishment costs

Step 4.1: Allocation of Prescribed TUoS

Allocate a portion of substation infrastructure and establishment costs to prescribed TUoS according to the ratio of the high voltage circuit breakers identified in Step 3.1 to the total number of high voltage circuit breakers connected to branches in the substation identified in Step 2.

Step 4.2 Calculate the Unallocated Substation Infrastructure Costs after TUoS Allocation

Calculate the Unallocated substation infrastructure cost by subtracting the amount calculated in Step 4.1 from the total substation infrastructure amount.

Step 4.3 Allocation of Prescribed Common Service

Allocate a portion of the substation infrastructure and establishment costs to prescribed common service based on to the ratio of the high voltage circuit breakers providing *prescribed common transmission services* identified in Step 3.2 to the total number of high voltage circuit breakers connected to branches in the substation. If the common service portion of substation infrastructure is greater than the *Unallocated costs*, then the *Unallocated portion* only is attributed to prescribed common service. In this instance, nothing will be attributed to prescribed entry and *prescribed exit services*.

Step 4.4 Calculate the Unallocated Substation Infrastructure Costs after Common Service Allocation

Calculate the Unallocated substation infrastructure cost by subtracting the amount calculated in Step 4.3 from the amount calculated in Step 4.2.

Step 4.5 Allocation of Prescribed Entry and Exit Service

Allocate the remaining substation infrastructure and establishment costs (calculated in Step 4.4) to each branch providing prescribed exit or entry services based on the ratio of the high voltage circuit breakers providing the entry or exit service to the branch to the total number of high voltage circuit breakers providing entry or exit services or in accordance with the TNSP's cost allocation methodology as appropriate.

Step 4.6 Allocation of Assets that provide both Entry and Exit Services

Clause 2.1(d)(3) of the AER guidelines states that a TNSP must provide:

Details of how the AARR will be allocated to derive the ASRR for each category of prescribed *transmission service*, including:

- (3) how asset costs which may be attributable to both *prescribed entry services* and *prescribed exit services* will be allocated.

There is currently no such arrangement within the Evoenergy network. However, Evoenergy proposes that where assets can be defined as both entry and exit services, that the allocation of the remainder of costs (after completing allocation to TUoS and

common service) to be allocated on a simple proportion of circuit breakers that immediately connect those customers, for each service against the total number of circuit breakers of entry and exit services combined.

Consider the worked example in Appendix 1. Suppose that next to the *negotiated* service, a generator is connected to the busbar via a single circuit breaker and next to that yet another DNSP exit load connected via a single circuit breaker. In that case, there are now two circuit breakers for DNSP exit loads, and one circuit breaker for generator entry service. In that case, two thirds of the remaining entry/exit service cost will be charged to the exit service and one third to the entry service.

This cost allocation will apply unless *negotiated* service arrangements apply between the parties, in which case the cost allocation in the particular circumstances will be *negotiated* between the parties

Step 4.7 Allocation of Exit Assets a Connection point with Multiple Transmission Customers

Clause 2.1(e)(1)C of the guidelines states that a TNSP must provide:

Details of how the *ASRR* for each category of prescribed *transmission service* will be allocated to each *transmission connection point*, including:

- (1) how the attributable *connection point* cost share for both *prescribed entry services* and *prescribed exit services* will be calculated in accordance with clause 6A.22.4 of the National Electricity Rules, including:
 - c) how asset costs allocated to *prescribed entry services* and *prescribed exit services* at a *connection point*, which may be attributable to multiple Transmission Network User s, will be allocated;

Where exit or entry assets are shared between several customers, whether load and/or generation, that the allocation of the remainder of costs (after completing allocation to TUoS and common service) to be allocated on a simple proportion of the circuit breakers that immediately connect that customer to the exit/entry point against the total number of the same circuit breakers. This is the same method as that outlined above at Step 4.6.

Notes

- Costs are only allocated in Step 4 until fully allocated.
- Consistent with clause 6A.23(d)(3) of the Rules it is possible that no costs will be attributed to entry and exit services.
- New and existing *negotiated* service assets are excluded from the analysis as any incremental establishment costs associated with them are taken to be included in the *negotiated* services charges on a causation basis.
- The assessment of standalone arrangements only needs to be conducted once per substation except where changes to the configuration of the substation occur.

Definition - Branches

As illustrated in Figure 1 a “Branch” is a collection of assets (e.g. lines, circuit breakers, capacitors, buses and transformers) that provide a *transmission service*.

Figure 1 Illustration of network branches

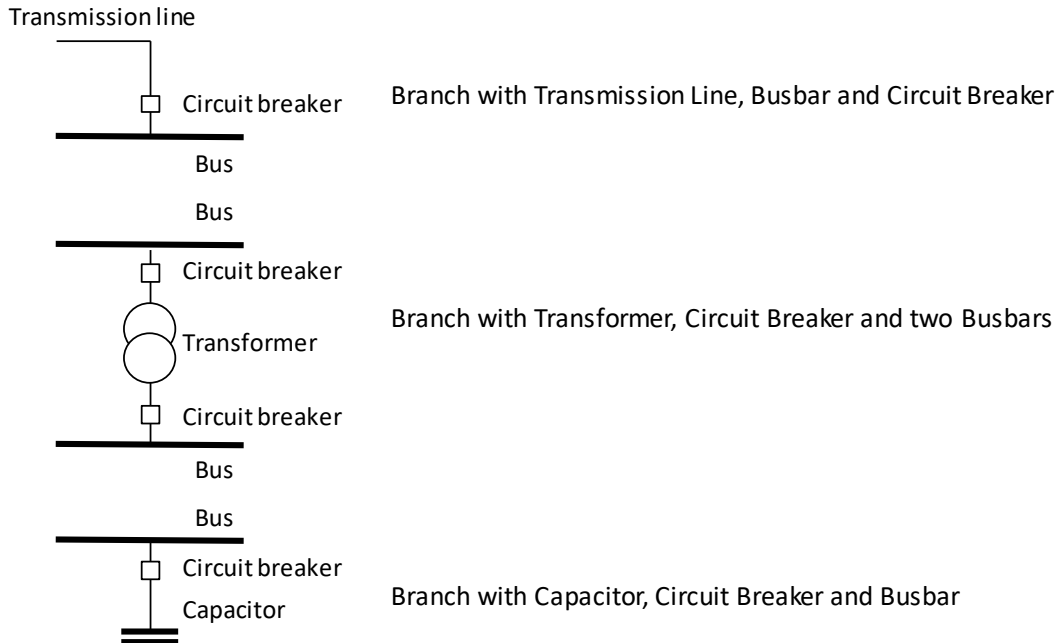

Worked Example 1: Substation costs priority ordering

Consider the substation in Figure 2 with an ORC value of, say, \$12 M. Of this, \$3 M is for the existing *negotiated* service, which does not form part of the regulated asset base and is not governed by 6A.23.2(d). Therefore, the *negotiated* service does not exist for the purposes of priority ordering, and the total infrastructure cost is \$9 M for allocation purposes.

Figure 2 Example 1 substation layout

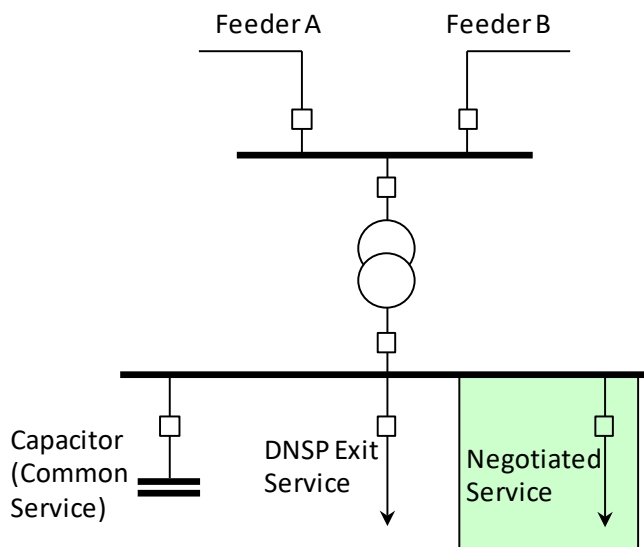

- Step 1:** The branches are Feeder A, Feeder B, DNSP Exit, Tie Transformer and Capacitor, the *negotiated* service branch is not considered as discussed above.
- Step 2:** The total number of circuit breakers directly connected to branches is 6 (again excluding the *negotiated* service).
- Step 3.1:** The stand-alone arrangement for the provision of *prescribed TUoS services* to an equivalent standard is shown in Figure 3 and consists of 2 circuit breakers.

Figure 3 Example 1 stand-alone *prescribed TUoS services*

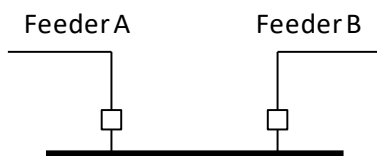

- Step 3.2:** The stand-alone arrangement for the provision of *prescribed common transmission services* to an equivalent standard is shown in Figure 4 and consists of 3 circuit breakers.

Figure 4 Example 1 stand-alone *prescribed common services*

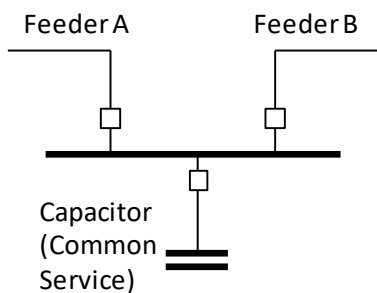

- Step 4:** Total infrastructure cost is \$9 M, excluding the *negotiated* service as discussed.
- Costs are allocated to prescribed TUoS in the ratio of the circuit breakers in the stand-alone arrangement to the total circuit breakers.
- Infrastructure Cost Allocated to TUoS = $(2/6) \times \$9m = \$3m$ Unallocated = $\$9m - \$3m = \$6m$
- Costs are allocated to prescribed common service in the ratio of the circuit breakers in the stand-alone arrangement to the total circuit breakers.
- Infrastructure Cost allocated to Common Service: $(3/6) \times \$9m = \$4.5m$ Unallocated = $\$6m - \$4.5m = \$1.5m$
- Remainder of Unallocated (calculated above) to be allocated to prescribed entry and *prescribed exit services*.
- Infrastructure Cost allocated to Exit = \$1.5m

This example is shown in Table 8.

Table 8 Priority ordering for Example 1

Asset Class	Breakers	Allocation	Unallocated
Substation Infrastructure Costs		\$9 M	\$9 M
Total Breakers	6		
TUoS Stand Alone Breakers	2		
1. Share to TUoS	=2/6	= 2/6 x \$9 M = \$3 M	\$6 M
Common Service Stand Alone Breakers	3		
2. Share to Common Service	=3/6	= 3/6 x \$9 M = \$4.5 M	\$1.5 M
3. Share to Entry and Exit Services		= \$1.5 M	0

Worked Example 2: Subtransmission substation cost priority ordering

Consider the substation in Figure 5, where the secondary voltage is 66 kV (and therefore capable of providing support to the higher voltage *transmission network*).

Figure 5 Example 2 substation layout

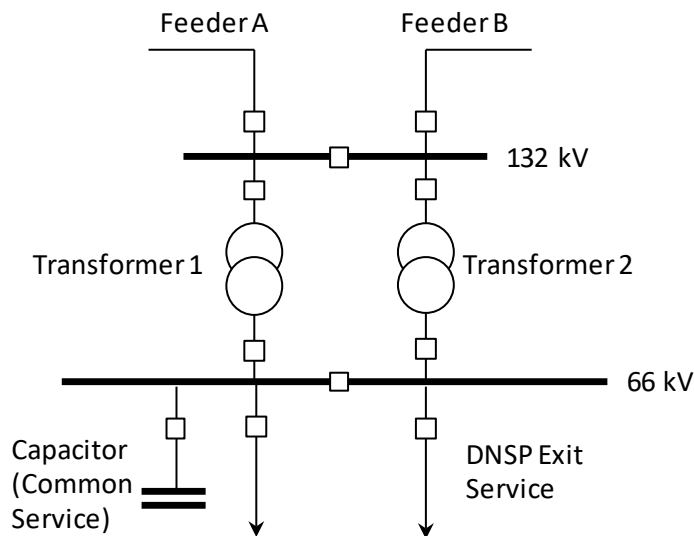

Step 1: The branches are Feeder A, Feeder B, DNSP Exit (2), Transformer 1, Transformer 2 and Capacitor.

Step 2: The total number of circuit breakers directly connected to branches is 9. The bus section breakers are not directly connected to any of the branches and are therefore ignored for the purposes of priority ordering.

Step 3.1: The stand-alone arrangement for the provision of *prescribed TUoS services* to an equivalent standard is shown in Figure 6 and consists of 2 circuit breakers. Note the bus section breaker is ignored since it is not connected to any of the branches.

Figure 6 Example 2 stand-alone *prescribed TUoS services*

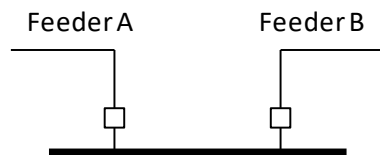

Step 3.2: The stand-alone arrangement for the provision of *prescribed common transmission services* to an equivalent standard is shown in Figure 7 and consists of 3 circuit breakers.

Figure 7 Example 2 stand-alone *prescribed common services*

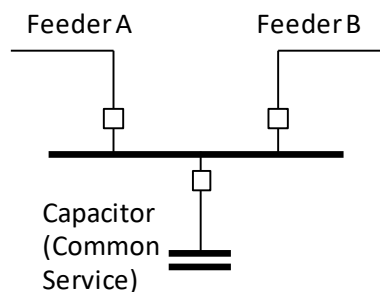

Step 4: Assume the total infrastructure cost is \$20 M.

Costs are allocated to prescribed TUoS in the ratio of the circuit breakers in the stand-alone arrangement to the total circuit breakers.

Infrastructure Cost Allocated to TUoS = $(2/9) \times \$20 \text{ M} = \4.44 M
 Unallocated = $\$20 \text{ M} - \$4.44 \text{ M} = \$15.55 \text{ M}$

Costs are allocated to prescribed common service in the ratio of the circuit breakers in the stand-alone arrangement to the total circuit breakers.

Infrastructure Cost allocated to Common Service: $(3/9) \times \$20 \text{ M} = \6.67 M
 Unallocated = $\$15.55 \text{ M} - \$6.67 \text{ M} = \$8.89 \text{ M}$

Remainder of Unallocated (calculated above) to be allocated to prescribed entry and *prescribed exit services*.

Infrastructure Cost allocated to Exit = \$8.89 M

This allocation is shown in Table 9.

Table 9 Priority ordering for Example 2

Asset Class	Breakers	Allocation	Unallocated
Substation Infrastructure Costs		\$20 M	\$20 M
Total Breakers	9		
TUoS Stand Alone Breakers	2		
1. Share to TUoS	=2/9	= 2/9 x \$20 M = \$4.44 M	\$15.55 M
Common Service Stand Alone Breakers	3		
2. Share to Common Service	=3/9	= 3/9 x \$20 M = \$6.67 M	\$8.89 M
3. Share to Entry and Exit Services		= \$8.89 M	0

Worked Example 3: Zone substation cost priority ordering

Consider the zone substation in Figure 8, where the secondary voltage is 11 kV (and therefore not capable of providing support to the higher voltage *transmission network*). The substation is considered to comprise two sections:

- The 132-kV section, which provides *transmission* support; and
- the transformers and 11 kV busbar, which supply the *distribution* system and provide a transmission exit services.

Figure 8 Example 3 substation layout

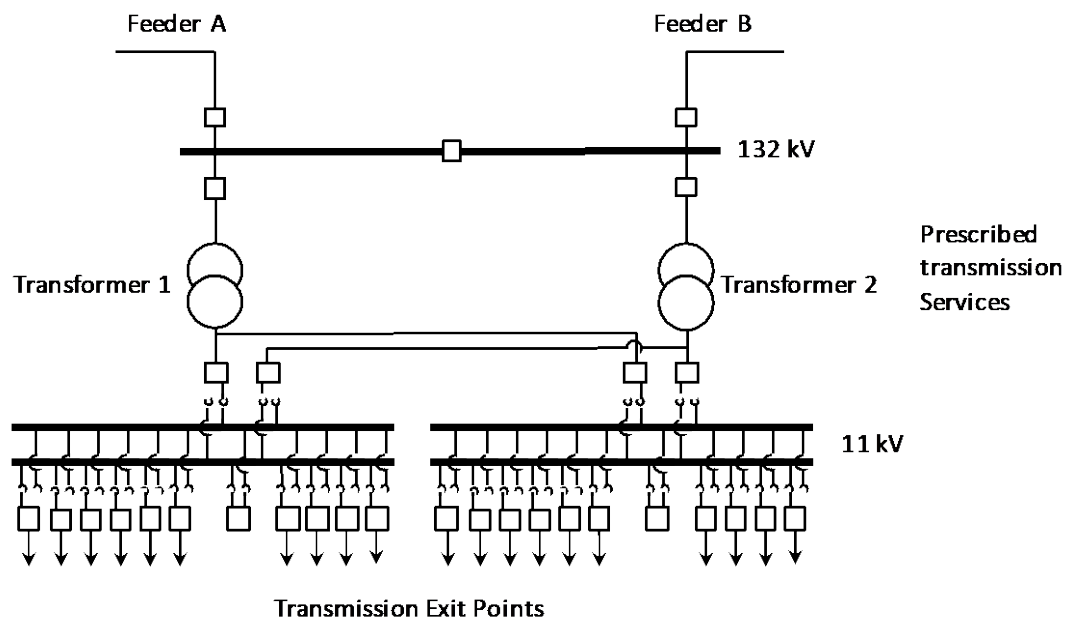

- Step 1:** The branches are Feeder A, Feeder B and DNSP Exit (Transformer 1 and Transformer 2).
- Step 2:** The total number of circuit breakers directly connected to branches is 4. The 132-kV bus section breaker is not directly connected to any of the branches and is therefore ignored for the purposes of priority ordering.
- Step 3.1:** The stand-alone arrangement for the provision of *prescribed TUoS services* to an equivalent standard is shown below and consists of 2 circuit breakers. Note the bus section breaker is ignored since it is not connected to any of the branches.

Figure 9 Example 3 stand-alone *prescribed TUoS services*

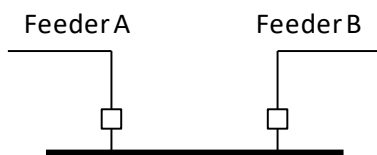

- Step 3.2:** There is no equipment providing common service at this location.
- Step 4:** Assume the total infrastructure cost is \$22 M, of which \$6 M is associated with the assets that provide *transmission services* and \$16 M associated with the *distribution* exit services (the 132/11 kV transformers and 11KV equipment).
- Costs are allocated to prescribed TUoS in the ratio of the circuit breakers in the stand-alone arrangement to the total circuit breakers.
- Infrastructure Cost Allocated to TUoS = $(2/4) \times \$6 \text{ M} = \3.0 M Unallocated = $\$6 \text{ M} - \$3 \text{ M} = \$3 \text{ M}$.
- There are no costs allocated to prescribed common service.
- Remainder of Unallocated (calculated above) to be allocated to prescribed entry and *prescribed exit services*.
- Infrastructure Cost allocated to Exit = $\$3 \text{ M} + \16 M (see above) = $\$19 \text{ M}$.

This allocation is shown in Table 10.

Table 10 Priority ordering for Example 3

Asset Class	Breakers	Allocation	Unallocated
Substation Infrastructure Costs		\$6 M	\$16 M
Total Breakers	4		
TUoS Stand Alone Breakers	2		
1. Share to TUoS	=2/4	= 2/4 x \$6 M = \$3 M	\$19 M
Common Service Stand Alone Breakers	0		
2. Share to Common Service	0	0	\$19 M
3. Share to Entry and Exit Services		= \$19 M	0