



Revised Proposed Pricing Methodology

1 July 2023 to 30 June 2028

Version 4.1

2 December 2022

ElectraNet Pty Ltd (**ElectraNet**) is the principal electricity *Transmission Network Service Provider (TNSP)* in South Australia.

As the owner and operator of South Australia's electricity transmission network, we play a vital role in powering the homes, businesses and communities of South Australia.

Our customers are at the heart of our decision making and we are trusted to deliver reliable and affordable energy solutions.

We remain committed to ongoing and genuine engagement with our customers and wider stakeholders in the interests of maximising the value of transmission services, recognising that transmission is playing an increasing role in a rapidly transforming power system.

For information about ElectraNet visit www.electranet.com.au.

Contact

For enquiries about this proposed *pricing methodology* please contact:

Bill Jackson
Pricing Manager
ElectraNet
52-55 East Terrace
Adelaide SA 5000

Copyright and Disclaimer

Copyright in the material in this document is owned by or licensed to ElectraNet. ElectraNet reserves all rights in relation to this material. Permission to publish, modify, alter, or use this material in any way must be sought in writing directly from ElectraNet.

This proposed pricing methodology for the period from 1 July 2023 to 30 June 2028 is submitted to the Australian Energy Regulator in accordance with the requirements of Chapter 6A of the National Electricity Rules. ElectraNet, its directors, its officers and shareholders disclaim any responsibility for the use of this document for a different purpose or in a different context.

Reasonable endeavours have been used to ensure that the information contained in this document is accurate at the time of writing. However, ElectraNet, its directors, officers and Shareholders give no warranty and accept no liability for any loss or damage incurred in reliance on this information. Forecasts, projections, and forward-looking statements included in this document are subject to change and amongst other things, reflect information, data, methodologies, legislation, judicial and tribunal decisions, regulatory guidance, assumptions, prevailing market estimates, assessments, standards, and factors current at the time of publication.

Revision Record					
Date	Version	Description	Author	Checked By	Approved By
May 07	1.0	Initial Version	Bill Jackson		Rainer Korte
May 12	2.0	Amended Version	Bill Jackson Pricing Manager	Simon Appleby Senior Manager Regulatory Affairs	Rainer Korte Executive Manager Network Strategy & Regulatory Affairs
2 Feb 15	2.1	Amended for IR Charging for informal review	Bill Jackson Pricing Manager	Simon Appleby Senior Manager Regulation and Land Development	Rainer Korte Executive Manager Asset Management
19 Feb 15	2.2	Amended for IR Charging	Bill Jackson Pricing Manager	Simon Appleby Senior Manager Regulation and Land Development	Rainer Korte Executive Manager Asset Management
3 Mar 15	2.2	Removal of draft and watermarks	Bill Jackson Pricing Manager	Simon Appleby Senior Manager Regulation and Land Development	Simon Appleby Senior Manager Regulation and Land Development
15 Mar 2017	3.0	Amended Version	Bill Jackson Pricing Manager	Simon Appleby Senior Manager Regulation and Land Management	Joanne McDonald Executive Manager Corporate Governance
31 Jan 2022	4.0	Amended version	Bill Jackson Pricing Manager	Simon Appleby Manager Regulation and Investment Planning	Rainer Korte Group Executive Asset Management
2 Dec 2022	4.1	Revised proposed version including system strength	Bill Jackson Pricing Manager	Jeremy Tustin Manager Regulation	Ashley Manna Executive Corporate Development

Contents

1.	Introduction	6
2.	Interpretation	6
3.	Prescribed Transmission Services	6
4.	Rules Requirements.....	7
5.	Pricing Methodology Guidelines Requirements	8
6.	Timetable for the provision of data	9
7.	Proposed Pricing Methodology	10
7.1	Background.....	10
7.2	Coordinating Network Service Provider.....	11
7.3	Aggregate Annual Revenue Requirement.....	12
7.4	Categories of transmission services.....	12
7.5	The pricing process	13
7.6	Cost allocation	13
7.7	Calculation of the attributable cost share for each category of service	14
7.8	Calculation of the Annual Service Revenue Requirement (ASRR)	15
7.9	Allocation of the ASRR to connection points	16
7.10	Modified Cost Reflective Network Pricing Methodology.....	19
7.11	Transmission prices and charges	21
7.12	System Strength Charges.....	26
7.13	Standby service arrangements	28
7.14	Excess demand charge	29
7.15	Setting of prescribed TUOS services locational prices between annual price publications	30
8.	Billing Arrangements	30
8.1	Billing for prescribed transmission services.....	30
8.2	Payments between Transmission Network Service Providers	31
9.	Prudential Requirements	31
9.1	Prudential requirements for prescribed transmission services.....	31
9.2	Capital contribution or prepayment for a specific asset.....	31
10.	Prudent Discounts	32
11.	Monitoring and Compliance	32
12.	Differences between Current and Proposed Pricing Methodologies	33

13.	Additional Information Requirements.....	33
14.	Conclusion	33
	Appendices	34
Appendix A	Structure of Transmission Pricing under Part J of Chapter 6A of Rules.....	35
Appendix B	Details of Cost Allocation Process.....	36
Appendix C	Cost Reflective Network Pricing Methodology	38
Appendix D	Ratings Adjustment for Calculating Utilisation Factors.....	40
Appendix E	Priority Ordering Methodology.....	41
Appendix F	Inter-regional Transmission Charging.....	53
Appendix G	- System Strength Charges	60

Tables

Table 1:	Summary of our changes in the <i>proposed pricing methodology</i> of January 2022	10
Table 2:	Hypothetical costs allocated to categories of prescribed transmission services.....	15
Table 3:	Hypothetical attributable cost shares.....	15
Table 4:	Hypothetical Annual Service Revenue Requirements	15
Table 5:	Hypothetical prescribed entry services ORCs	16
Table 6:	Hypothetical attributable connection point cost shares	16
Table 7:	Hypothetical connection point ASRRs (entry).....	17
Table 8:	Hypothetical connection point ASRRs (exit)	17
Table 9:	Derivation of AARR to be allocated to the four services	57
Table 10:	Asset allocations to categories of prescribed transmission services	58
Table 11:	Calculation of ASRR	58
Table 12:	Standard CRNP methodology allocation and I/C cost share.....	59
Table 13:	Modified load export charge	59

1. Introduction

ElectraNet Pty Ltd (**ElectraNet**) is the principal electricity *Transmission Network Service Provider (TNSP)* and *System Strength Service Provider* in South Australia.

This revised proposed *pricing methodology* will apply for the regulatory control period from 1 July 2023 to 30 June 2028¹ and amends the proposed *pricing methodology* submitted in January 2022 to address the changes required by the introduction of System Strength Charging in accordance with the AEMC's Rule determination, Efficient Management of System Strength on the Power System Rule 2021, October 2021.

This pricing methodology complies with the requirements of Chapter 6A of the National Electricity Rules (the **Rules**) and the AER's *pricing methodology guidelines* dated 25 August 2022.

2. Interpretation

All terms in this proposed *pricing methodology* that are italicised have the meaning given to them in Chapter 10 of the Rules. All other terms which are defined in the *pricing methodology guidelines* or, where no definition is provided in that document, in the Rules will have the same meaning when used in this proposed *pricing methodology*.

A reference to the Rules is taken to be a reference to the current version of the National Electricity Rules, version 188, which commenced operation on 29 September 2022 as that version of the Rules is amended from time to time.

3. Prescribed Transmission Services

ElectraNet's proposed *pricing methodology* relates to the provision of *prescribed transmission services* in the South Australian *region* by ElectraNet and Murraylink Transmission Company Pty Ltd (**MTC**) and any other TNSP who provides *prescribed transmission services* within the South Australian *region*. These services include:

- Shared transmission services provided to Transmission Customers directly connected to the transmission network (*prescribed TUOS services*);
- Connection services provided to connect the SA Power Networks distribution network to the transmission network (*prescribed exit services*);
- Grandfathered *connection services* provided to *Generators* and *Transmission Customers* directly *connected* to the *transmission network* for *connections* that were in place or committed to be in place on 9 February 2006 (*prescribed entry services* and *prescribed exit services*); and
- Services required under the Rules or in accordance with *jurisdictional electricity legislation* that are necessary to ensure the integrity of the *transmission network*, including the maintenance of *power system security* and assisting in the planning of the *power system* (*prescribed common transmission services*, other than *system strength transmission services*); and

1 Subject to clauses 6A.24.3 and 6A.24.4 of the Rules which set down the basis for setting prices pending approval of the pricing methodology and pending the approval of maximum allowed revenue respectively.

- *System strength transmission services*, which is the provision of facilities or services to meet the standard in clause S5.1.14 at system strength nodes. *System strength transmission services* are classified as *prescribed common transmission services*.

For the avoidance of doubt the proposed *pricing methodology* does not relate to the provision of *negotiated transmission services* or other *transmission services* provided by ElectraNet (*non-regulated transmission services*) that are not subject to economic regulation under Chapter 6A of the Rules.

4. Rules Requirements

Clause 6A.24.1(b) of the Rules states that a *pricing methodology* is a methodology, formula, process, or approach that, when applied by a TNSP (or a *Co-ordinating Network Service Provider* on behalf of TNSPs within a *region*):

1. allocates the aggregate annual revenue requirement for prescribed transmission services provided by the TNSP to each category of prescribed transmission services;
2. provides for the manner and sequence of adjustments to the *annual service revenue requirement*;
3. allocates the annual service revenue requirement to connection points (other than connection points of any Market Network Service Provider); and
4. determines the structure and recovery of prices for each *category of prescribed transmission services* under 6A.23.4(a).

Clause 6A.24.1(b1) of the Rules further states that in addition to complying with any other requirements under Chapter 6A, the *pricing methodology* of a TNSP that is the *Co-ordinating Network Service Provider* for a *region* must provide for:

1. the allocation of the *AARR* for *prescribed transmission services* provided by TNSPs within that *region*, including any allocation of the *AARR* as agreed between TNSPs in accordance with clause 6A.29.3;
2. the calculation of *modified load export charges* consistent with clause 6A.29A.2;
3. the allocation and billing of *modified load export charges*:
 - (i) receivable by other *Co-ordinating Network Service Providers* in *interconnected regions*; and
 - (ii) payable to other *Co-ordinating Network Service Providers* in *interconnected regions*;

to each TNSP within its *region* under clause 6A.29A.5; and

4. the allocation of proceeds from *auctions* or a portion of *settlements residue* receivable by or payable to the TNSP in its *region* as referred to in clause 6A.23.3(b)(1).

The Rules also require that the *pricing methodology* satisfy principles and guidelines established by the Rules. In particular, clause 6A.10.1(e)² of the Rules requires that a proposed *pricing methodology* must:

1. give effect to and be consistent with the *Pricing Principles for Prescribed Transmission Services* (i.e. the principles set out in Rule 6A.23 of the Rules); and

² Also clause 6A.24.1(c)

2. comply with the requirements of, and contain or be accompanied by such information as is required by, the *pricing methodology guidelines* made for that purpose under Rule 6A.25 of the Rules.

Further, under clause 6A.24.1(d)³ of the Rules a TNSP must comply with:

- the *pricing methodology* approved by the AER as part of a *transmission determination* that applies to that TNSP, and
- any other applicable requirements in the Rules,

when the TNSP is setting the prices that may be charged for the provision of *prescribed transmission services*.

5. Pricing Methodology Guidelines Requirements

The *pricing methodology guidelines* supplement and elaborate on the *Pricing Principles for Prescribed Transmission Services* contained in Chapter 6A of the Rules in so far as they specify or clarify:

- the information that is to accompany a *proposed pricing methodology*;
- permitted pricing structures for the recovery of the locational component of prescribed TUOS services;
- permissible postage stamping structures for the recovery of the *adjusted non-locational component of prescribed TUOS services* and *prescribed common transmission services*;
- the types of transmission system assets that are directly attributable to each *category of prescribed transmission services*;
- the permitted methodologies for determining the *system strength unit price* component of the *system strength charge*;
- principles for determining forecast *annual system strength revenue* and estimated actual *annual system strength revenue*; and
- the parts of a proposed pricing methodology, or the information accompanying it that will not be publicly disclosed without the consent of the TNSP.

All key elements of ElectraNet's *proposed pricing methodology* are permissible under the *pricing methodology guidelines*. These elements include:

- calculation of the locational component of *prescribed TUOS services* costs using the *modified cost reflective network pricing methodology*;
- the locational prescribed TUOS services price being based on contract agreed maximum demand;
- the *postage-stamp basis* of pricing structures for the non-locational component of *prescribed TUOS services* and *prescribed common transmission services* being based on contract agreed maximum demand or historical energy;

³ The formatting of the actual words used in clause 6A.24.1(d) of the Rules has been changed (by separating out the two dot points) to emphasise the fact that ElectraNet must comply with both its pricing methodology and the other applicable requirements of the Rules.

- the methodology for setting the *system strength unit price* based on long run average costs, covering a 10 year period, at each *system strength node* and the basis for applying an annual indexation to the *system strength unit price*;
- the methodology for forecasting or estimating *annual system strength revenues*;
- the methodology for implementation of priority ordering (being the priority ordering approach under clause 6A.23.2(d) of the Rules);
- a description of how asset costs which may be attributable to both *prescribed entry services* and *prescribed exit services* will be allocated at a *connection point*;
- a description of billing arrangements under clause 6A.27 of the Rules;
- a description of prudential requirements as outlined in clause 6A.28 of the Rules;
- the inclusion of hypothetical worked examples;
- a description of any differences between the *pricing methodology* applied during the current *regulatory control period* and that proposed for the next *regulatory control period*; and
- a description of how ElectraNet intends to monitor and develop records of its compliance with its approved *pricing methodology*, the *Pricing Principles for Prescribed Transmission Services* (clause 6A.23 of the Rules) and Part J of Chapter 6A of the Rules in general.

6. Timetable for the provision of data

As required by clause 6A.29A.4(e), each TNSP located in the *region* is required to provide the CNSP with all information reasonably required for the calculation of the MLEC estimate.

To facilitate this information transfer, Section 2.6 of the *pricing methodology guidelines* requires a CNSP to specify a timetable for the provision of all necessary data for the calculation of the *inter-regional* and *intra-regional transmission charges*.

The following timetable for the provision of data will facilitate the calculation of the MLEC to apply in the *region* by 15 February each year. It should be noted that customers must provide notification of annual demand adjustments by 1 February each year, even if the customer’s Transmission Connection Agreement specifies a later date. This notification requirement arises from the Distribution Network Pricing Arrangements Rule (27 November 2014), which brought forward the dates of publication of inter-regional and intra-regional transmission prices.

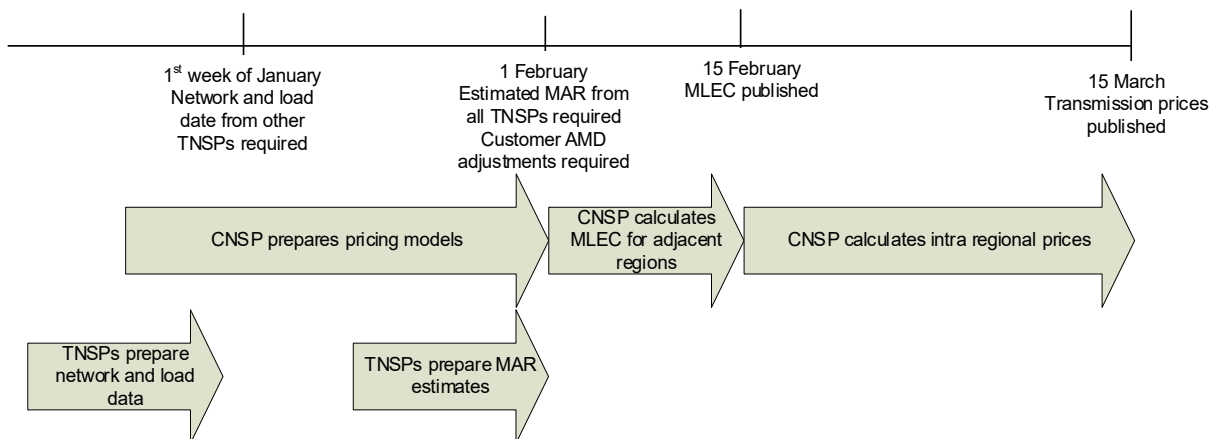

7. Proposed Pricing Methodology

7.1 Background

ElectraNet’s first published *transmission pricing methodology*, applicable from 1 January 2003 to 30 June 2008, was developed in accordance with Part C of Chapter 6 of the applicable Rules at that time, and was approved by the ACCC. From 1 July 2008 onwards, ElectraNet’s *pricing methodology* has been prepared in accordance with the *Pricing Principles for Prescribed Transmission Services*, Part J of the Chapter 6A of the Rules and the AER’s *pricing methodology guidelines*.

In our current revenue determination, the AER approved relatively minor changes to our previous pricing methodology to:

- improve the clarity and use of defined terms; and
- provide clarity regarding the provisions for the grandfathering of existing or 'legacy' aggregated contracts.

Our proposed pricing methodology for the 2023-24 to 2027-28 regulatory period submitted in January 2022 introduced further minor amendments limited to those necessary to give effect to rule changes and provide additional clarity to customers. The table below summarises the changes which were accepted by the AER in their draft decision of September 2022.

Table 1: Summary of our changes in the proposed pricing methodology of January 2022

Proposed change	Rationale for the change
Clarify the timing requirements for information provision and the obligation on our customers to provide information by the due date.	The purpose of these amendments is to remove any uncertainty regarding the timeframes for preparing transmission prices. In particular, the proposed drafting clarifies that customers must provide notification of annual demand adjustments by 1 February each year, even if the customer’s Transmission Connection Agreement specifies a later date. We have also moved this material so that it appears earlier in the pricing methodology (now Section 6), to give this issue greater prominence.
Clarify that considering the increasing prevalence of reverse flows at connection points, that load is energy being taken from the transmission network	This proposed change is considered helpful in clarifying that load connection points which have material generation must be split into load generator pairs to ensure costs are correctly allocated to load connection points. The drafting also clarifies that the load component (offtake) will also be used for energy-based charging.
Provide for the non-locational component of prescribed TUOS to be adjusted for National Transmission Planning (NTP) function fees advised by AEMO.	This is a change to the methodology that reflects a recent Rule change, which introduced clause 6A.23.3(e)(6) to enable TNSPs to recover NTP function fees. Previously, AEMO did not recover these charges from TNSPs and therefore it did not feature in the pricing methodology.
Confirm that the optimised replacement cost of non-prescribed transmission system assets that are designated network assets or identified user shared assets is zero.	This change reflects the requirements of new clause S6A.3.2(1), which was introduced by the National Electricity Amendment (Connection to dedicated connection assets) Rule 2021 No. 7.

Clarify the billing arrangements for dedicated connection assets.	This change is a helpful clarification regarding the arrangements for dedicated connection assets which have been subject to recent change, following the National Electricity Amendment (Connection to dedicated connection assets) Rule 2021 No. 7.
Clarify ElectraNet's approach to prudent discounts.	The purpose of this change is to provide additional information for the benefit of our customers on the matters we will consider in negotiating a prudent discount. The proposed drafting reflects the requirements of clause 6A.26.1(f) of the Rules. In addition, we explain that ElectraNet will apply to the AER to recover any discount in accordance with clause 6A.26.2 of the Rules.

This amended *pricing methodology*, which will be applicable from 1 July 2023 to 30 June 2028, includes amendments to the proposed *pricing methodology* approved by the AER in September 2022 to:

- include a methodology for determining the *system strength unit price* component of the *system strength charge*; and
- include a methodology for determining forecast *annual system strength revenue* and estimated *actual annual system strength revenue*.

7.2 Coordinating Network Service Provider

In accordance with clause 6A.29.1 of the Rules, ElectraNet is the *Co-ordinating Network Service Provider* for the South Australian *region* and collects both ElectraNet's and MTC's regulated revenue entitlements via ElectraNet's *prescribed transmission service* prices.

These prices incorporate the full impact of the *modified load export charges* and no payments or liabilities arise between ElectraNet and MTC under clause 6A.29A.5(a) of the Rules⁴.

As the *Co-ordinating Network Service Provider*, ElectraNet is responsible for:

1. the allocation of all relevant *AARR* within the South Australian *region*, including any allocation of the *AARR* as agreed between TNSPs in accordance with clause 6A.29.3 of the Rules;
2. the calculation of modified load export charges and any adjustments to the modified load export charges in accordance with the Rules payable by Co-ordinating Network Service Providers in interconnected regions; and
3. the allocation and billing of *modified load export charges* and any adjustments to the *modified load export charges* in accordance with the Rules payable or receivable to or from *Co-ordinating Network Service Providers* in *interconnected regions* to each TNSP within the South Australian *region*.

MTC is required to advise ElectraNet annually of the *AARR* for its *transmission system* assets which are used to provide *prescribed transmission services* within the South Australian *region*. It is also required to provide any other information reasonably required by ElectraNet to ensure the proper calculation of *prescribed transmission service* prices in South Australia⁵.

⁴ Notwithstanding this, bills will be issued to satisfy the requirements of clause 6A.29A.5(b) of the Rules.

⁵ This obligation will also apply to any additional appointing providers requiring the services of the Co-ordinating Network Service Provider during the currency of this pricing methodology.

Additional requirements with respect to the provision of information for the calculation of the *modified load export charges* are specified in Appendix F.

7.3 Aggregate Annual Revenue Requirement

The revenue that a TNSP may earn in any regulatory year of a regulatory control period from the provision of prescribed transmission services is known as the maximum allowed revenue⁶.

The AARR is calculated in accordance with clause 6A.22.1 of the Rules as:

“...the *maximum allowed revenue* referred to in clause 6A.3.1 adjusted:

1. in accordance with clause 6A.3.2,
2. by subtracting the operating and maintenance costs expected to be incurred in the provision of *prescribed common transmission services* and expected *system strength service payments*; and
3. by any allocation as agreed between *Transmission Network Service Providers* in accordance with clause 6A.29.3.”

The adjustments referred in item 1 above could relate to a number of factors including:

- reopening of the *revenue determination* for capital expenditure (not being a *pass through event* or a *contingent project*) under clause 6A.7.1 of the Rules;
- *network support pass through* under clause 6A.7.2 of the Rules;
- *cost pass through* under clause 6A.7.3 of the Rules;
- *service target performance incentive scheme* outcomes under clause 6A.7.4 of the Rules;
- *contingent projects* under Rule 6A.8 of the Rules; or
- revocation of *revenue determination* for wrong information or error under clause 6A.15 of the Rules.

The costs referred in item 2 above are derived from budget projections and include:

- *network* switching and operations;
- administration and management of ElectraNet's business;
- *network* planning and development; and
- general overheads.

7.4 Categories of transmission services

ElectraNet's and MTC's AARRs are recovered from charges for the following *categories of prescribed transmission services*:

- *Prescribed entry services* which include *entry services* provided by assets that are directly attributable to serving a *Generator* or group of *Generators* at a single *connection point* and are deemed to provide a *prescribed transmission service* by virtue of the operation of clause 11.6.11 of the Rules;

⁶ Clause 6A.3.1 of the Rules.

- *Prescribed exit services*, which include *exit services* provided by assets that are directly attributable to serving a *Transmission Customer* or group of *Transmission Customers* at a single *connection point* and:
 - (a) are deemed to provide a *prescribed transmission service* by virtue of the operation of clause 11.6.11 of the Rules; or
 - (b) are *exit services* provided to a *Distribution Network Service Provider (DNSP)*;
- *Prescribed common transmission services*, which are services that provide equivalent benefits to all *Transmission Customers* without any differentiation based on their location, and therefore cannot be reasonably allocated on a locational basis. These services include *system strength transmission services*, which are the provision of facilities or services to meet the standard in clause S5.1.14 at *system strength nodes*; and
- *Prescribed transmission use of system services*, which include services that provide benefits to *Transmission Customers* depending on their location within the *transmission system*, that are shared to a greater or lesser extent by all users across the *transmission system* and are not *prescribed common transmission services*, *prescribed entry services* or *prescribed exit services*.

7.5 The pricing process

The determination of *prescribed transmission service* prices involves four steps:

1. Allocation of the costs of *transmission system* assets to the *categories of prescribed transmission service*, to the extent to which assets are directly attributable to the provision of a *category of prescribed transmission services* (Section 7.6);
2. Calculation of the *attributable cost shares* (Section 7.7);
3. Calculation of the *Annual Service Revenue Requirement (ASRR)* by the allocation of the *AARR* to each *category of prescribed transmission services* in accordance with the *attributable cost share* for that *category of prescribed transmission services* (Section 7.8); and
4. Allocation of the *ASRR* for *prescribed entry services*, *prescribed exit services* and *prescribed TUOS services* to each *connection point* in accordance with the principles set out in clause 6A.23.3 of the Rules (Section 7.9).

Each step is described in further detail below.

7.6 Cost allocation

The **first step** in calculating *prescribed transmission service* prices is to allocate the costs of *transmission system* assets to the *categories of prescribed transmission services* listed in Section 7.4 above, to the extent to which assets are directly attributable to the provision of a *category of prescribed transmission services*.

The delineation between the assets that provide *prescribed entry services*, *prescribed exit services*, *prescribed TUOS services* and *prescribed common transmission services* is set out in clause 2.4 of the *pricing methodology guidelines*.

The ElectraNet cost allocation process assigns the optimised replacement cost (**ORC**)⁷ of all *prescribed transmission services* assets to either *prescribed common transmission services* (assets that benefit all *Transmission Customers*) or individual *network* pricing branches (*transmission lines* and *transformers*). Each *network* pricing branch is then defined as entry, exit or shared network. The pricing branches are used to determine the costs of the *transmission system* assets directly attributable to each *category of prescribed transmission services*, as required under Chapter 6A of the Rules. This cost allocation process is explained in more detail in Appendix B.

7.6.1 Assets attributable to prescribed entry services and prescribed exit services

In the case of a shared *connection asset* (such as a *transformer*) serving multiple *connection points*, which may provide both *prescribed entry services* and *prescribed exit services*, the cost of the shared *connection asset* will be allocated to the appropriate category or categories of *prescribed transmission services* using an appropriate causal cost allocator⁸. For example:

- *generation or reactive plant* nameplate rating capacity or contract agreed maximum demand supplied by the specified *category of prescribed transmission services* as a percentage of the total capacity and demand of all categories of *prescribed transmission services* at that location: - Costs are attributable based on the capacity and/or contract agreed maximum demand agreed with the *Transmission Network User(s)*;
- unit of plant method: - Costs are allocated based on the number of units of plant installed (typically circuit breakers) where these units of plant can be attributed to a particular *category of prescribed transmission service*; or
- as negotiated between the TNSP and the *Transmission Network User*.

This process would also be adopted to allocate shared costs to individual *connection points*.

7.7 Calculation of the attributable cost share for each category of service

The **second step** in calculating *prescribed transmission service* prices is the calculation of the *attributable cost shares*. The *attributable cost share* for each *category of prescribed transmission services* is calculated in accordance with clause 6A.22.3 of the Rules as the ratio of:

1. The costs of the *transmission system* assets directly attributable to the provision of that *category of prescribed transmission services*; to
2. The total costs of all the TNSP's *transmission system* assets directly attributable to the provision of *prescribed transmission services*,

where these amounts are determined as detailed in Section 7.6 above.

For example, if the ORC's of *prescribed transmission services* assets have been allocated to the applicable *categories of prescribed transmission services* as shown in Table 2 below then the *attributable costs shares* are calculated as shown in the hypothetical example below:

$$\begin{aligned} \text{Attributable cost share}_{\text{EXIT}} &= \text{ORC}_{\text{EXIT}} / \text{ORC}_{\text{TOTAL}} \\ &= \$4,083,333 / \$43,050,000 \\ &= 0.095 \end{aligned}$$

7 Consistent with clause 6A.22.3(b) of the Rules.

8 This is consistent with ElectraNet's cost allocation methodology which is used to allocate costs between prescribed transmission services, negotiated transmission services and non-regulated transmission services.

with the *attributable cost shares* of the other *categories of prescribed transmission services* calculated in the same manner, as shown in Table 3 below.

Table 2: Hypothetical costs allocated to categories of prescribed transmission services

Category	ORC
Exit service	4,083,333
Entry service	716,667
TUOS service	37,500,000
Common Service	750,000
Total	43,050,000

Table 3: Hypothetical attributable cost shares

Category	ORC	Attributable cost share
Exit service	4,083,333	0.095
Entry service	716,667	0.017
TUOS service	37,500,000	0.871
Common Service	750,000	0.017
Total	43,050,000	1.000

7.8 Calculation of the Annual Service Revenue Requirement (ASRR)

The **third step** in calculating *prescribed transmission service* prices is to allocate the AARR to each *category of prescribed transmission services* in accordance with the *attributable cost share* for that *category of prescribed transmission services*.

This allocation results in the *ASRR* for each *category of prescribed transmission services*.

Assuming an AARR of \$2,504,434 and applying the *attributable cost shares* determined above, the *ASRR* for each *category of prescribed transmission services* is calculated as:

$$\begin{aligned}
 ASRR_{\text{EXIT}} &= AARR \times \text{Attributable cost share}_{\text{EXIT}} \\
 &= \$2,504,434 \times 0.095 \\
 &= \$237,548
 \end{aligned}$$

with the *ASRRs* of the other *categories of prescribed transmission services* calculated in the same manner.

Table 4: Hypothetical Annual Service Revenue Requirements

Category	Attributable cost share	ASRR
Exit service	0.095	237,548
Entry service	0.017	41,692
TUOS service	0.871	2,181,563
Common Service	0.017	43,631
Total	1.000	2,504,434

7.9 Allocation of the ASRR to connection points

The **fourth step** in calculating *prescribed transmission service* prices is to allocate the ASRR for *prescribed entry services*, *prescribed exit services* and *prescribed TUOS services* to each *connection point* in accordance with the principles of clause 6A.23.3 of the Rules.

7.9.1 Prescribed entry services

The whole of the ASRR for *prescribed entry services* is allocated to each *connection point* in accordance with the *attributable connection point cost share* for *prescribed entry services* that are provided by the TNSP at that *connection point*.

The *attributable connection point cost share* for *prescribed entry services* is the ratio of the costs of the *transmission system* assets directly attributable to the provision of *prescribed entry services* at that *connection point* to the total costs of all the TNSP's *transmission system* assets directly attributable to the provision of *prescribed entry services*.

For example, if two *Generators*, Gen A1 and Gen A2, receive *prescribed entry services* and the cost allocation process has allocated the ORCs of assets *directly attributable* to *prescribed entry services* to them as shown in Table 5.

$$\begin{aligned} \text{Attributable connection point cost share}_{\text{GEN A1}} &= \text{ORC}_{\text{GEN A1}} / \text{ORC}_{\text{ENTRY}} \\ &= \$250,000 / \$716,667 \\ &= 0.349 \end{aligned}$$

with the *attributable connection point cost share* of the other *Generator* being calculated in the same manner as shown in Table 6.

Table 5: Hypothetical prescribed entry services ORCs

Entry	ORC
Gen A1	250,000
Gen A2	466,667
Total ORC of prescribed entry assets	716,667

Table 6: Hypothetical attributable connection point cost shares

Entry	ORC	Attributable connection point cost share
Gen A1	250,000	0.349
Gen A2	466,667	0.651
Total	716,667	1.000

The ASRR allocated to the Gen A1 *connection point* is calculated as follows:

$$\begin{aligned} \text{ASRR}_{\text{GEN A1}} &= \text{ASRR}_{\text{ENTRY}} \times \text{Attributable connection point cost share}_{\text{GEN A1}} \\ &= \$41,692 \times 0.349 \\ &= \$14,544 \end{aligned}$$

with the ASRR for the Gen A2 *connection point* being calculated in the same manner.

Table 7: Hypothetical connection point ASRRs (entry)

Entry	ORC	Attributable connection point cost share	Connection point ASRR
Gen A1	250,000	0.349	14,544
Gen A2	466,667	0.651	27,148
Total	716,667	1.000	41,692

7.9.2 Prescribed exit services

The whole of the *ASRR* for *prescribed exit services* is allocated to each *connection point* in accordance with the *attributable connection point cost share* for *prescribed exit services* that are provided by the TNSP at that *connection point*.

The *attributable connection point cost share* for *prescribed exit services* is the ratio of the costs of the *transmission system* assets directly attributable to the provision of *prescribed exit services* at that *connection point* to the total costs of all the *transmission system* assets directly attributable to the provision of *prescribed exit services*.

The *ASRRs* of the *prescribed exit services connection points* are calculated in the same manner as for the *prescribed entry services connection points*.

Table 8: Hypothetical connection point ASRRs (exit)

Exit	ORC	Attributable connection point cost share	Connection point ASRR
Load A1	1,050,000	0.257	61,084
Load A2	883,333	0.216	51,388
Load B1	1,550,000	0.380	90,171
Load C1	600,000	0.147	34,905
Total	4,083,333	1.000	237,548

7.9.3 Prescribed Transmission Use of System (or TUOS) services

The *prescribed TUOS services ASRR* is recovered from:

- *Prescribed TUOS services* (locational component); and
- *Prescribed TUOS services* (the adjusted non-locational component).

Clause 6A.23.3(a) of the Rules requires that:

“The *annual service revenue requirement* for *prescribed TUOS services* is to be allocated between a locational component (*pre-adjusted locational component*) and a non-locational component (*pre-adjusted non-locational component*) either:

1. as to 50% to each component; or
2. an alternative allocation to each component, that is based on a reasonable estimate of future *network* utilisation and the likely need for future *transmission* investment, and that has the objective of providing more efficient locational signals to *Market Participants*, *Intending Participants* and end users.”

The locational component of the *prescribed TUOS services ASRR* is to be adjusted in accordance with clause 6A.23.3(b)-(d) of the Rules including by:

- subtracting estimated inter-regional settlements residue auction proceeds or any portion of settlements residue allocated to the directional interconnector which is not subject to a settlement residue distribution agreement or SRD agreement (This adjustment is calculated in accordance with 6A.23.3(f)⁹ of the Rules). The estimated proceeds are converted to an equivalent asset replacement cost, which is offset against the asset replacement cost of the relevant interconnector network assets. If the equivalent asset replacement cost is greater than the interconnector network asset costs, then the interconnector network asset costs are set to zero and the outstanding portion of the estimated proceeds is offset against the non-locational prescribed TUOS service component. The reduced network costs are used as an input to the modified cost reflective network pricing methodology (or modified CRNP methodology)¹⁰;
- adding or subtracting the estimated *modified load export charge* determined in accordance with clause 6A.29A of the Rules. This adjustment is calculated in accordance with 6A.23.3(f) of the Rules; and
- If the *adjusted locational component* is a positive amount, then it is to be allocated to *transmission network connection points* of *Transmission Customers* using the *modified CRNP methodology* in accordance with clause 6A.23.3(c) of the Rules. If the *adjusted locational component* is a negative amount, then the *adjusted locational component* is deemed to be zero and the non-locational component adjusted to recover this amount in accordance with clause 6A.23.3(d) of the Rules.

The adjusted share of the *ASRR* is allocated between *transmission network connection points* based on the estimated proportionate use of the relevant *transmission system* assets by each *Transmission Customer* using the *modified CRNP methodology*.

The *CRNP methodology* allocates a proportion of shared *network* costs to individual *Transmission Customer connection points*. ElectraNet applies the *CRNP methodology* using the TPRICE cost reflective *network* pricing software approved by the AER for use by TNSPs in the *NEM*.

The *CRNP methodology* requires three sets of input data:

- an electrical (loadflow) model of the *network*;
- a cost model of the *network* (the results of the cost allocation process described in Appendix B); and
- an appropriate set of *load/generation* patterns.

Appendix C describes the *CRNP methodology* in more detail.

The remainder of the *ASRR* (the *pre-adjusted non-locational component*) is to be adjusted in accordance with clause 6A.23.3(e) of the Rules by:

- subtracting the absolute value of any negative adjusted locational component (referred to above);

9 The difference between budget estimates and actual amounts in the settlement residue auction proceeds (Clause 6A.23.3(b)(1)), the modified load export charge (MLEC) (Clause 6A.23.3(b)(2)), and the under and over recovery amounts (Clause 6A.23.3(e)(5)) are to be adjusted in accordance Clause 6A.23.3(f) of the Rules.

10 In this way estimated settlements residue auction proceeds recover a portion of the AARR allocated to shared network costs on a locational basis.

- by subtracting or adding any remaining *settlements residue* (not being *settlements residue* referred to in the determination of the locational component but including the portion of *settlements residue* due to *intra-regional loss factors*) which is expected to be distributed or recovered (as the case may be) to or from the TNSP in accordance with clause 3.6.5(a) of the Rules;
- for any *over-recovery amount* or *under-recovery amount* from previous years including an adjustment in accordance with 6A.23.3(f);¹¹
- for any shortfall or surplus that arises from limiting the change in locational prices at a *connection point* (Clauses 6A.23.4(c) & (d) of the Rules); and
- for any amount arising as a result of the application of prudent discounts in accordance with Clause 6A.26.1(d) to (g) of the Rules; and
- adding the amount of NTP function fees advised in accordance with clauses 6A.23.3(e)(6) and 2.11.3(ba) of the Rules.

7.10 Modified Cost Reflective Network Pricing Methodology

The essential difference between standard *CRNP methodology* and *modified CRNP methodology* is that in calculating the *network costs* to be recovered on a locational basis (i.e. *prescribed TUOS services – adjusted locational component*):

- The standard *CRNP methodology* allocates shared *network costs* to *connection points* on the basis of optimised replacement costs and assumes a 50-50 split between the locational and non-locational components of *network charges*;
- The *modified CRNP methodology* uses utilisation adjusted replacement costs. An average rate of return¹² is applied to the resulting costs allocated to each *connection point* to determine its share of the locational component of shared *network charges* (i.e. the arbitrary 50 - 50 split used with the standard *CRNP methodology* is removed). *Prescribed TUOS services – non-locational charges* recover the balance of *network costs* (the costs not recovered by *prescribed TUOS services – locational charges*).

The *modified CRNP methodology* is intended to encourage better utilisation of existing assets by discounting the costs allocated to under-utilised elements relative to those that are more heavily utilised.

TPRICE calculates utilisation factors based on the maximum loading of each *network pricing branch* over the range of operating conditions analysed and pricing branch ratings provided as input to TPRICE.

In determining the utilisation factors required by Schedule 6A.3.3(2) of the Rules the *modified CRNP methodology* ensures that asset utilisation is based on the maximum flow allowed on *network elements* within the normal operating constraints of the *network* to prevent inefficient discounting of costs in the meshed *network*.

As TPRICE performs its calculations based on system normal operating conditions (i.e. with all elements in service) and does not carry out contingency analysis that is representative of the normal

11 The difference between budget estimates and actual amounts in the settlement residue auction proceeds (Clause 6A.23.3(b)(1)), the modified load export charge (Clause 6A.23.3(b)(2)), and the under recovery amount and over recovery amount (Clause 6A.23.3(e)(5)) are to be adjusted in accordance Clause 6A.23.3(f) of the Rules.

12 The rate of return is calculated so that prescribed TUOS services – locational charges would recover the full cost of the shared network when all network elements are assumed to be 100% utilised.

operating constraints of the *network*, it is necessary to apply an adjustment factor reducing branch ratings for input to TPRICE to ensure that utilisation factors appropriately take into account *network* contingencies.

Appendix D describes the ratings adjustment for calculation of utilisation factors in more detail.

7.10.1 Load and generation data

As noted in Appendix C, the choice of operating conditions is important in developing prices using the *CRNP methodology*. ElectraNet has flexibility in the choice of operating conditions but notes that prior to 2006 the Rules set out principles that should apply in determining the sample of operating conditions considered. Of particular note is the requirement that operating conditions to be used are to include at least 10 days with high system demand, to ensure that loading conditions, which impose peak flows on all *transmission elements*, are captured.

Schedule 6A.3.2(3) of the Rules is less prescriptive requiring that the allocation of *dispatched generation* to *loads* be over a range of actual operating conditions from the previous *financial year* and that the range of operating scenarios be chosen so as to include the conditions that result in most stress on the *transmission network* and for which *network* investment may be contemplated.

Clause 2.2(a) of the *pricing methodology guidelines* requires that prices for the recovery of the locational component of *prescribed TUOS services* are based on demand at times of greatest utilisation of the *transmission network* and for which *network* investment is most likely to be contemplated in accordance with clause 6A.23.4(e) of the Rules.

The use made of the *network* by particular *loads* and *Generators* will vary considerably depending on the *load* and *generation* conditions on the *network*. For this reason a number of operating scenarios are examined with different *load* and *generation* patterns.

In selecting those operating scenarios it is important to recognise that the operating conditions that impose most stress on particular *network elements* may occur at times other than for system peak demand.

The TPRICE capacity method of cost allocation (used by ElectraNet) automatically captures the peak loading conditions on *network elements* from the sample of operating conditions analysed.

ElectraNet, therefore, uses the full year of operating data (i.e. 365 days of half hourly data) to avoid the need for judgement concerning an appropriate set of operating conditions.

Load connection points which have material generation must be split into load generator pairs to ensure costs are correctly allocated to load connection points. The load component (offtake) will also be used for energy-based charging.

Consistent with clause 2.2(f) of the *pricing methodology guidelines* where actual operating conditions from the previous complete *financial year* are unavailable for a *connection point*, as would be the case for a new *connection point*, an estimate based on the contract agreed maximum demand and other characteristics of the *load* would be used to allocate costs to that *connection point*.

7.10.2 Network support costs

Unless otherwise required by the Rules *network* support service costs will be recovered on a locational basis where the alternative *network augmentation* costs would be recovered on this basis.

An estimate of *network* support costs is converted to an equivalent asset replacement cost¹³ that is added to the asset replacement cost of the *transmission* assets these *network* support services support.

ElectraNet recovers these costs on a locational basis as part of its *modified CRNP methodology*.

7.11 Transmission prices and charges

7.11.1 Prescribed entry services and prescribed exit services prices and charges

Prescribed entry services and *prescribed exit services* prices are calculated to recover the *prescribed entry services* and *prescribed exit services* ASRRs from the *Transmission Network Users* who are served by the relevant *connection assets*.

The *prescribed entry services* ASRR is recovered as a fixed annual charge for each relevant *connection point*, which fixed annual charge is in turn recovered on the basis of a fixed \$/day entry price.

Similarly, the *prescribed exit services* ASRR is recovered as a fixed annual charge for each relevant *connection point*, which fixed annual charge is in turn is recovered on the basis of a fixed \$/day exit price.

7.11.2 Prescribed TUOS services – locational component prices and charges

Consistent with the provisions of clause 2.2(c)(1) of the *pricing methodology guidelines*, the *prescribed TUOS services – adjusted locational component* prices and charges for each *connection point* will be determined by reference to the contract agreed maximum demand for that *connection point*¹⁴.

It follows that each *connection point* should have a contract agreed maximum demand for the purposes of determining the *prescribed TUOS services – adjusted locational component* prices and charges for that *connection point*. The only exceptions to this general requirement are where:

- ElectraNet and the *Transmission Customer* have agreed to adopt a contract agreed maximum demand for a 'group of exit points'¹⁵ listed by ESCOSA from time to time in clause 2.4.1 of the ETC; or
- ElectraNet agrees to grandfather an existing or 'legacy' aggregated contract agreed maximum demand arrangement after considering the criteria outlined below.

Subject to any relevant requirements of the *applicable regulatory* instruments, ElectraNet will consider grandfathering an existing or 'legacy' aggregated contract agreed maximum demand arrangement (i.e. an arrangement under which an aggregated contract agreed maximum demand has been previously agreed for a group of *connection points* that are not listed as a 'group of exit points' in clause 2.4.1 of the ETC) if:

- that arrangement was in place prior to 31 March 2016; and

13 Using the same rate of return that is subsequently used to determine prescribed TUOS services charges – locational component (TUOS Usage charges under old Rules).

14 Usually referred to as the 'Agreed Maximum Demand' or 'AMD' in ElectraNet's transmission connection agreements. The methodology for dealing with exceedance of the contract agreed maximum demand is referenced in the transmission connection agreement and is summarised in section 7.13.

15 As defined in clause 1.5 of the ETC.

- the aggregated contract agreed maximum demand that was agreed pursuant to that arrangement is not varied after that date.

If the aggregated contract agreed maximum demand under a grandfathered arrangement is varied after 31 March 2016, the grandfathered arrangement will cease to apply as and from the end of the then current *regulatory year* unless otherwise advised by ElectraNet.

The *ASRR* for the locational component of *prescribed TUOS services* described in Section 7.9.3 is priced on a contract agreed maximum demand basis (\$/MW/day), where the contract agreed maximum demand is specified in, and re-negotiated in accordance with, *Transmission Customer's connection agreements*.

The *modified CRNP methodology* outlined in S6A.3 of the Rules and detailed in this proposed *pricing methodology* describes the process for cost allocation for the locational component of *prescribed TUOS services*, which results in a lump sum dollar amount to be recovered at each *connection point* as described in Appendix C.

This lump sum dollar amount for each *connection point* is divided by the product of the number of days in the forthcoming *financial year* and the contract agreed maximum demand for that *connection point* prevailing at the time *transmission* prices are published, to calculate the locational price for each *connection point*¹⁶ and is expressed as \$/MW/day.

As provided for under clause 6A.23.4(b)(2) of the Rules, *prescribed TUOS services* locational prices must not change by more than 2% per annum at *connection points* relative to the *load weighted average prescribed TUOS services* locational price for the *region* unless either of the circumstances described in clause 6A.23.4(b)(3) of the Rules apply – see the following paragraph. The balance of any revenue shortfall or surplus resulting from these price caps is recovered or offset as appropriate by adjusting the *prescribed TUOS services* non-locational prices and charges in accordance with clauses 6A.23.4(c) and 6A.23.4(d) of the Rules.

The *prescribed TUOS services* locational price at a *connection point* is not subject to this 2% per annum limitation:

- to the extent that the change in prices relate to the adjusted *modified load export charge* as per clause 6A.23.4(b)(3)(i) of the Rules; or
- per clause 6A.23.4(b)(3)(ii) of the Rules, if since the commencement of the previous *regulatory year*:
 - the *load* at the *connection point* has materially changed;
 - in connection with that change, the *Transmission Customer* requested a renegotiation of its *connection agreement* with the TNSP; and
 - the *AER* has approved the change of more than 2 per cent per annum.

In the event that a *Transmission Customer* requests a material change in contract agreed maximum demand at an existing *connection point*, or if ElectraNet forms the view that the *load* at the *connection point* has otherwise materially changed, ElectraNet will seek approval from the *AER* to set the *prescribed TUOS services* – locational price for that *connection point* without the limitation specified in clause 6A.23.4(b)(2) of the Rules.

¹⁶ The connection point for the purposes of determining the prescribed TUOS services locational prices, will be the agreed point of supply established between ElectraNet and the Transmission Customer under the applicable connection agreement. This is also the point at which the contract agreed maximum demand is fixed and the historical or current metered energy is measured.

Prescribed TUOS services locational charges are determined for each *connection point* providing *prescribed TUOS services* by multiplying the *prescribed TUOS services* locational price by the contract agreed maximum demand for that *connection point* prevailing during the relevant *billing period*, and multiplying this amount by the number of days in the *billing period*.

For the avoidance of doubt, forecast *prescribed TUOS services* locational charges will be calculated using the contract agreed maximum demand prevailing at the time prices are determined as distinct from the actual *prescribed TUOS services* locational charges which will be calculated using the contract agreed maximum demand prevailing during the *billing period* to which the charges relate.

Any *over-recovery amount* or *under recovery amount* arising from variances between forecast contract agreed maximum demands and the contract agreed maximum demands used for calculating *prescribed TUOS services* locational charges will be addressed by way of an *under-recovery amount* or an *over-recovery amount* adjustment when calculating prices for the following *financial year*.

7.11.3 Prescribed TUOS services – non-locational component prices and charges

Prices for recovery of the *adjusted non-locational component* of *prescribed TUOS services* are set on a *postage-stamp basis* in accordance with clause 6A.23.4(e) of the Rules.

Consistent with the provisions of clause 2.3(c)(1) of the *pricing methodology guidelines* prices on a *postage-stamp basis* will be determined on the basis of contract agreed maximum demand or historical energy for each *connection point* and are calculated annually as follows.

Consistent with Section 7.11.2 above, each *connection point* must have a contract agreed maximum demand or a historical metered energy offtake or current metered energy offtake for the purposes of determining the *prescribed TUOS services – adjusted non-locational component* prices and charges for that *connection point* unless one of the limited exceptions permit the use of an aggregated contract agreed maximum demand.

Each *financial year* ElectraNet will determine the following two prices to apply at every *connection point*:

- an energy-based price that is a price per unit of historical metered energy offtake or current metered energy offtake at a *connection point* expressed as \$/MWh; and
- a contract agreed maximum demand price that is a price per unit of contract agreed maximum demand at a *connection point* expressed as \$/MW/day.

Either the energy-based price or the contract agreed maximum demand price will apply at a *connection point* providing *prescribed TUOS services* except for those *connection points* where a *Transmission Customer* has negotiated reduced charges for the *adjusted non-locational component* of *prescribed TUOS services* in accordance with clause 6A.26.1 of the Rules (prudent discounts).

The energy-based price and the contract agreed maximum demand price is determined so that:

- a *Transmission Customer* with a *load factor* in relation to its *connection point* equal to the median *load factor* for *connection points* with *Transmission Customers* connected to the *transmission network* in the *region* or *regions* is indifferent between the use of the energy-based price and the contract agreed maximum demand price; and
- the total amount to be recovered by the *adjusted non-locational component* of *prescribed TUOS services* does not exceed the ASRR for this category of *prescribed transmission service*.

When applying the energy-based price, the *prescribed TUOS services* non-locational component charge for a *billing period* is calculated for each *connection point* by:

- multiplying the energy-based price by the metered energy offtake at that *connection point* in the corresponding *billing period* two years earlier (i.e. historical metered energy offtake); or
- multiplying the energy-based price by the metered energy offtake at that *connection point* in the same *billing period* (current metered energy offtake) if the historical metered energy offtake is unavailable; or
- multiplying the energy based price by the current metered energy offtake if the historical metered energy offtake is significantly different to the current metered energy offtake (this method of calculation is only expected to be applied where the conditions necessary to enact clause 6A.23.4(b)(3)(ii) of the Rules¹⁷ have been satisfied or a *connection point* is operated in a standby arrangement as detailed in Section 7.12 of this proposed *pricing methodology*).

When applying the contract agreed maximum demand price, the *prescribed TUOS services* – non-locational component charge for a *billing period* will be calculated for each *connection point* by multiplying the contract agreed maximum demand price by the contract agreed maximum demand for the relevant *connection point* (prevailing during the *billing period* to which the charge relates) and multiplying this amount by the number of days in the *billing period*.

For the avoidance of doubt forecast *prescribed TUOS services* non-locational charges will be calculated using the contract agreed maximum demand prevailing at the time prices are determined as distinct from the actual contract agreed maximum demand-based charges which will be calculated using the contract agreed maximum demand prevailing during the *billing period* to which the charges relate.

Any *over-recovery amount* or *under-recovery amount* arising from variances between forecast contract agreed maximum demands and the contract agreed maximum demands used for calculating charges will be addressed by way of an *under-recovery amount* or *over-recovery amount* adjustment when calculating prices for the following *financial year*.

The energy-based price or the contract agreed maximum demand price that applies for the *adjusted non-locational component* of *prescribed TUOS services* at a *connection point* will be the one which results in the lower estimated charge for that *prescribed transmission service* over a financial year.

7.11.4 Prescribed common transmission service prices and charges

Prices for *prescribed common transmission services* are set on a *postage-stamp basis* in accordance with clause 6A.23.4(f) of the Rules.

Consistent with the provisions of clause 2.3(c)(1) of the *pricing methodology guidelines* prices on a *postage-stamp basis* will be determined on the basis of contract agreed maximum demand or historical energy for each *connection point* and calculated in a manner identical to that described for *prescribed TUOS services* non-locational charges in the previous section.

In accordance with clause 6A.23.3(h) of the Rules the operating and maintenance costs expected to be incurred in the provision of *prescribed common transmission services* and expected *system strength service payments*, which are deducted from the *maximum allowed revenue* to form the *AARR*, are added to the *ASRR* for *prescribed common transmission services* and recovered through *prescribed common transmission service prices and charges*.

¹⁷ The clause in Part J of Chapter 6A of the Rules which allows for the relaxation of the side constraints on *TUOS* locational prices at a *connection point*.

In accordance with clause 6A.23.3(h1), in addition to the adjustment under paragraph (h), the ASRR for *prescribed common transmission services* must be adjusted by subtracting the forecast *annual system strength revenue* for the *regulatory year* and any adjustment for under or over recovery from previous years, calculated in accordance with clause 6A.23.3A(b). These adjustments enable:

- Revenue from *system strength charges* to be recovered from *System Strength Transmission Service Users* in accordance with section 6.10 of this *pricing methodology*;
- Any residual annual costs in providing *system strength services* that are not forecast to be recovered from *system strength charges* to be recovered from all *Transmission Customers* through *common service charges*. These services provide equivalent benefits to all *Transmission Customers* without any differentiation based on their location; and
- Any under- or over-recovery in relation to *annual system strength revenue* for years $t - 1$ and $t - 2$ to be corrected by adjusting the *annual service revenue requirement* for *prescribed common transmission services* for year t .

To give effect to clauses 6A.23.3(h1) and 6A.23.3A(a)(1) and (2), we will forecast the *annual system strength revenue* for year t and the estimate of the actual *annual system strength revenue* for year $t - 1$. While our forecasting methodology will change in light of new information and experience, it will comply with the following principles specified in paragraphs 2.1(k)(7), 2.1(k)(8) and 2.8 of the AER's *pricing methodology guidelines*:

- (1) the methodologies will be reasonable and appropriate for their purpose;
- (2) the cost of implementing the methodologies will be proportionate to the expected level of materiality of the impact of any inaccuracy in estimates or forecasts;
- (3) the methodologies will utilise relevant existing information to the extent possible, including information from *connection agreements* and, where relevant, applications to connect;
- (4) the methodologies will be consistent with any relevant parts of the *system strength requirements methodology* and *system strength impact assessment guidelines*;
- (5) the methodologies will be consistent with other relevant parts of the *pricing methodology* and our approach to other relevant forecasts or estimates; and
- (6) estimated actual annual system strength revenue will be based on actual data for part of the regulatory year where actual data is available and updated forecasts for the remainder of the regulatory year.

For the purpose of this *pricing methodology*, it is noted that:

- There is limited historical data that could inform our forecast revenue from *system strength charges*; and
- There is no information available regarding the likelihood that connection applicants will elect to pay the *system strength charge* in relation to the proposed *connection* or alteration.

Given the limited historical data, our methodology for forecasting the annual revenue from *system strength charges* will have regard to the following information:

- actual contracts for the provision of *system strength services* for the relevant year;

- forecast new connections for the relevant year having regard to known connection enquiries and connection applications;
- forecast of the new connections that will elect to pay the *system strength charge*, having regard to the facility seeking or likely to seek connection and an estimate of the costs of self-remediation; and
- the estimated applicable *system strength unit prices*; system strength locational factors; and *system strength quantity* applicable to each actual and forecast contract for the provision of *system strength services*.

Our forecasting method will be reviewed and updated as historical data becomes available. Over time, an increasing proportion of our *system strength charges* will be obtained from existing connections, rather than new connections. As a result, the accuracy of our revenue forecasts will tend to improve in future regulatory periods.

7.12 System Strength Charges

The charging arrangements described in this section satisfy the requirements of clause 6A.23.5 of the Rules and paragraph 2.7 of the AER's *pricing methodology guidelines*.

7.12.1 Overview of the charging arrangements

The System Strength Transmission Service User for a system strength connection point must pay an annual system strength charge for the system strength connection point calculated in accordance with this section 6.10. The annual system strength charge is payable in equal monthly instalments. System strength charges come into effect from 1 July 2023.

If the obligation to pay the *system strength charge* in relation to a *system strength connection point* commences part way through a *regulatory year*, the *annual system strength charge* will be calculated on a pro rata basis and charged for the remaining months of the regulatory year.

The *annual system strength charge* for a *system strength connection point* for a *regulatory year* will be calculated in accordance with the following formula:

$$SSC = SSUP \times SSL \times SSQ$$

where:

SSC is the *annual system strength charge* for the regulatory year (in \$).

SSUP is the *system strength unit price* for the *system strength node*. SSUP will be the same for each *regulatory year* in a *system strength charging period*, except to the extent the *pricing methodology guidelines* permit indexation, in accordance with clause 6A.23.5(f).

SSL is the *system strength locational factor* applicable to the *system strength connection point*, calculated in accordance with the *system strength impact assessment guidelines*. SSL will be the same for each *regulatory year* in a *system strength charging period*.

SSQ is the *system strength quantity* applicable to the relevant *system strength connection point* (in MVA). It should be noted that:

- SSQ is the product of (1) the short circuit ratio and (2) the rated active power, calculated in accordance with clause 6A.23.5(j).

- If a change to SSQ comes into effect part way through a regulatory year, the monthly instalments of the *annual system strength charge* for the remaining months of the *regulatory year* will be calculated using the new *system strength quantity*, in accordance with clause 6A.23.5(k).

The *system strength charging period* commences from the start of the second regulatory year in a regulatory control period to the end of the first regulatory year in its next regulatory control period.

7.12.2 System Strength Unit Price

A System Strength Unit Price (**SSUP**) will be set for each *system strength node* on the transmission network. In accordance with the Rules and the AER's *pricing methodology guidelines*, the methodology determines the SSUP according to the 'forward-looking' long run average cost of providing the *system strength capacity* at each *system strength node*.

SSUP will be calculated in real terms and indexed annually in accordance with this methodology. Appendix G provides worked examples to illustrate the application of the methodology, which is described below.

The SSUP is a price per MVA which reflects the forecast long run average costs of providing *System Strength Transmission Services* at the relevant *system strength node* calculated as follows:

$$SSUP = \frac{\text{The total long run capital and operating costs of providing an efficient quantity of system strength at a system strength node, over a period of } t \text{ years}}{\text{The total system strength hosting capacity provided by that system strength node, over a period of } t \text{ years}}$$

Where:

Long run means the costs of providing *system strength capacity* at a *system strength node*, having regard to the actual and forward-looking costs of providing the required capacity at that node. Specifically:

- The long run costs include ElectraNet's actual costs of providing *system strength capacity* where the forward-looking costs are higher than ElectraNet's actual costs; and
- The long run costs include the future forward-looking costs of providing *system strength capacity* where these costs are lower than ElectraNet's actual costs.

Capital and operating costs of providing System Strength Transmission Services means:

- The annualised capital costs of providing the required *system strength capacity* at a *system strength node* in each year for a period of *t years*;
- The annual operating costs required to operate and maintain network assets employed to provide the required *system strength capacity* at a *system strength node* in each year for a period of *t years*; and
- The annual costs of contracts with non-network service providers to provide the required *system strength capacity* at a *system strength node* in each year for a period of *t years*.

Total system strength hosting capacity means the quantity of system strength provided by a *system strength node* to supply an efficient quantity of system strength to connection points in each year for a period of *t years*.

t years is 10 years.

Cost allocation

In relation to the process of allocating *capital and operating costs* to *system strength nodes*, it should be noted that:

- The *capital and operating costs* of providing *system strength capacity* may be attributable to more than one *system strength node*. In such cases, the costs of providing that *system strength capacity* will be allocated to each of the relevant *system strength nodes* on a reasonable basis to reflect the percentage of that capacity used at each of those nodes.
- The *capital and operating costs* of providing *system strength capacity* at a *system strength node* may include an allocation from one or more sources of *system strength capacity*, whether that source is a network investment or a contract with a non-network service provider.
- The *capital and operating costs* of providing *system strength capacity* at a *system strength node* will have regard to the National Electricity Amendment (Operational Security Mechanism) Rule 2022.

Compliance

The methodology described above is consistent with clause 2.7(a) of the AER's *pricing methodology guidelines* which require that the SSUP must:

- (1) be based on a forecast of the long run average costs of providing system strength transmission services at the relevant system strength node;
- (2) use a period of at least 10 years when forecasting long run costs.
- (3) set a price on a dollars per MVA per year basis;
- (4) set a price that is fixed for the *system strength charging period*; and
- (5) set a price for each *system strength node*.

Indexation

In accordance with clause 2.7(b) of the AER's *pricing methodology guidelines*, the SSUP will be indexed annually by the same inflation series the AER uses to index the maximum allowed revenue under the revenue determination from one year to the next.

7.13 Standby service arrangements

This provision addresses the situation where ElectraNet has agreed to provide *prescribed transmission services* to a *Transmission Customers* on a standby basis (such as to cover the *outage of onsite generation*).

If ElectraNet agrees to provide a standby service, the *Transmission Customer's connection agreement* must specify the terms and conditions applying to the provision of this standby service.

Without limiting the other terms and conditions that could apply to the provision of a standby service, the *connection agreement* would be required to specify the contract agreed maximum demand required to be available to the *Transmission Customers* under normal operating conditions and a greater demand that may be sought on a standby basis (standby demand) subject to the operational condition of the *transmission network* at the time the standby arrangements are to be called on. The *transmission network* would be planned and developed to satisfy the contract agreed maximum demand rather than the standby demand.

The conditions to temporally vary from the contract agreed maximum demand must be specified in the *Transmission Customer's connection agreement* and must ensure that compliance with the ETC is maintained.

In this instance the *Transmission Customers* will pay *prescribed exit services* charges (if applicable), *prescribed TUOS services* – locational component charges, *prescribed TUOS services* – non-locational component charges and *prescribed common transmission services* based:

- on the contract agreed maximum demand under normal operating conditions; and
- the standby demand and/or actual *energy* consumption during times that the standby service is actually utilised for *energy* delivery to the *Transmission Customers*.

For the avoidance of doubt:

- where a standby service arrangement has been agreed between ElectraNet and the relevant *Transmission Customers*, the *Transmission Customer's connection agreement* must specify (amongst other things) a contract agreed maximum demand and the conditions under which an excess demand charge as detailed in Section 7.13 will apply;
- where a *Transmission Customer's* forecast contract agreed maximum demand¹⁸ results in the need to *augment* the *transmission network* access to the standby service arrangements may be withdrawn by ElectraNet; and
- nothing in this Section 7.13 obliges ElectraNet to agree to provide a standby service arrangement requested by a *Transmission Customer*.

7.14 Excess demand charge

Subject to the provisions of Section 7.13, if the *Transmission Customer's* actual *maximum demand* at a *connection point* exceeds the contract agreed maximum demand for that *connection point* at any time during a *financial year* then an excess demand charge applies and the actual *maximum demand* for that *connection point* will become the contract agreed maximum demand, for that *connection point* in accordance with the requirements of the *Transmission Customer's connection agreement*.¹⁹

In addition, ElectraNet may recover from the *Transmission Customer* the incremental charges the *Transmission Customer* would have paid to ElectraNet during the entire *financial year* if the contract agreed maximum demand had been the actual *maximum demand*.

¹⁸ As defined in the Electricity Transmission Code

¹⁹ As noted in Section 7.11.2, each connection point must have a contract agreed maximum demand for the purposes of determining the prescribed TUOS services – adjusted locational component prices and charges for that connection point unless one of the aggregate contract agreed maximum demand exceptions apply.

The excess demand charge for a *connection point* is determined by multiplying the charge rate specified in ElectraNet's published Transmission Service Price Schedule (\$/kW) by the amount by which the contract agreed maximum demand has been exceeded (kW) at that *connection point* (unless an alternative method has been included in the *Transmission Customer's connection agreement*).

The charge rate (\$/kW) is calculated as three times the maximum revenue which ElectraNet can earn from *prescribed transmission services* during the pricing period (\$), divided by the aggregate of all contracted agreed maximum demands for *Transmission Customer's connected to the transmission network*.

7.15 Setting of prescribed TUOS services locational prices between annual price publications

If ElectraNet is required to set a *prescribed TUOS services* locational price at a new *connection point* without a previously calculated *prescribed TUOS services* locational price, an interim price not subject to the side constraints of clause 6A.23.4(b)(2) will be determined. At an existing *connection point* where the *load* has changed significantly after *prescribed TUOS service* locational prices have been determined and published, an interim price will be calculated subject to clause 6A.23.4(b)(3) of the Rules. This will be calculated using the prevailing pricing models with demands estimated in a manner consistent with clause 2.2(f) of the *pricing methodology guidelines*.

A price subject to the side constraints of clause 6A.23.4(b)(2) of the Rules will be determined and published at the next annual price determination.

8. Billing Arrangements

8.1 Billing for prescribed transmission services

Consistent with clause 6A.27.1 of the Rules, ElectraNet will calculate the *transmission service* charges payable by *Transmission Network Users* and *system strength charges* payable by *System Strength Transmission Service Users* for each *connection point* in accordance with the *transmission service* prices published under clause 6A.24.2 of the Rules.

Where charges are determined for *prescribed transmission services* from *metering data*, these charges will be based on kW or kWh obtained from the *metering data* managed by AEMO.

ElectraNet will issue invoices to *Transmission Network Users* for *prescribed transmission services* and to *System Strength Transmission Service Users* for *system strength charges*, which satisfy or exceed the minimum information requirements specified in clause 6A.27.2 of the Rules on a monthly basis or as specified in the *transmission connection agreement*.

In the case of a *dedicated connection asset*, ElectraNet will issue invoices for *prescribed transmission services* to the *financially responsible market participant* (FRMP) for the *dedicated connection asset* (or nominee) based on usage at the *transmission network connection point*.

In addition to the minimum information requirements in clause 6A.27.2(a), a bill for a *connection point* issued directly to a *Distribution Network Service Provider* or *Transmission Network Service Provider* relating to *system strength charges* will separately identify the *system strength charge* by *connection point*.

Consistent with clause 6A.27.3 of the Rules a *Transmission Network User* must pay charges for *prescribed transmission services* properly charged to it and billed in accordance with this proposed *pricing methodology* by the date specified on the invoice.

8.2 Payments between Transmission Network Service Providers

Consistent with clause 6A.27.4 of the Rules, where ElectraNet is the *Co-ordinating Network Service Provider* under clause 6A.29.1 of the Rules, it will pay to each other relevant TNSP the revenue which is estimated to be collected during the following year by ElectraNet as charges for *prescribed transmission services* for the use of *transmission systems* owned by those other TNSPs.

Such payments will be determined by ElectraNet as the *Co-ordinating Network Service Provider* for the *region*.

Financial transfers payable under clause 6A.27.4 of the Rules will be paid in equal monthly instalments or as documented in revenue collection agreements negotiated between the parties.

9. Prudential Requirements

9.1 Prudential requirements for prescribed transmission services

Consistent with clause 6A.28.1 of the Rules, ElectraNet may require a *Transmission Network User* to establish *prudential requirements* for either or both *connection services* and *transmission use of system services*. These *prudential requirements* may take the form of, but need not be limited to, capital contributions, pre-payments or financial guarantees.

The requirements for such *prudential requirements* will be negotiated between the parties and specified in the applicable *transmission connection agreement*.

9.2 Capital contribution or prepayment for a specific asset

ElectraNet notes that no capital contributions or prepayments have been made in respect of *prescribed transmission services* assets as at the date of this proposed *pricing methodology*.

Consistent with clause 6A.28.2 of the Rules, where ElectraNet is required to construct or acquire specific assets to provide *prescribed connection services* or *prescribed TUOS services* to a *Transmission Network User*, ElectraNet may require that *Transmission Network User* to make a capital contribution or prepayment for all or part of the cost of the new assets installed.

If a capital contribution is required, any contribution made will be taken into account in the determination of *prescribed transmission service* prices applicable to that *Transmission Network User* by way of a proportionate reduction in the ORC of the asset(s) used for the allocation of *prescribed transmission service* charges or as negotiated between the parties.

If a prepayment is required any prepayment made will be taken into account in the determination of *prescribed transmission service* prices applicable to that *Transmission Network User* in a manner to be negotiated between the parties.

The treatment of such capital contributions or prepayments for the purposes of a *revenue determination* will in all cases be in accordance with the relevant provisions of the Rules.

10. Prudent Discounts

ElectraNet may, but is not required to, agree with a *Transmission Customer* to charge lower prices (reduced charges) for *prescribed TUOS services* and *prescribed common transmission services* (other than *system strength transmission services*) provided to that *Transmission Customer*, than the prices determined in accordance with this proposed *pricing methodology*.

In the event that ElectraNet agrees to charge a *Transmission Customer* reduced charges, ElectraNet will, in accordance with clause 6A.26.1(d)-(g) of the Rules, update the adjusted non-locational component of *prescribed TUOS services* and/or the *prescribed common transmission services* prices and charges to *Transmission Customers* to recover the discount amount.

Where for any reason ElectraNet does not recover the proportion of the discount amount that it is allowed to recover in any financial year it will recover any shortfall in a subsequent financial year via adjustments to the adjusted non-locational component of *prescribed TUOS services*.

In considering a request for reduced charges ElectraNet will have regard to:

- the discount amount being no larger than that necessary to prevent the beneficiary inefficiently pursuing a credible alternative; and
- the discount not placing other customers in a worse position than if the discount was not offered²⁰.

Where ElectraNet seeks to recover greater than 70 percent of the discount amount through these charges, ElectraNet will apply to the AER for approval to recover the proposed recovery amount in accordance with clause 6A.26.2.

ElectraNet notes that none of its *Transmission Customers* receive prudent discounts as at the date of this proposed *pricing methodology*.

11. Monitoring and Compliance

As a regulated business ElectraNet is required to maintain extensive compliance monitoring and reporting systems to ensure compliance with its Transmission Licence, *revenue determination*, the ETC and the Rules together with numerous other legislative obligations.

In order to monitor and maintain records of its compliance with its approved pricing methodology, the *Pricing Principles for Prescribed Transmission Services*, and Part J of Chapter 6A of the Rules, ElectraNet proposes to:

- Maintain the specific obligations arising from Part J of Chapter 6A of the Rules in its compliance management system.
- Maintain electronic records of the annual calculation of *prescribed transmission service* prices and supporting information, and
- Periodically subject its *transmission* pricing models and processes to functional review by suitably qualified persons.

²⁰ Including both current and future augmentation costs associated with the load.

12. Differences between Current and Proposed Pricing Methodologies

This revised proposed *pricing methodology*, applicable from 1 July 2023 to 30 June 2028, proposes amendments to the proposed *pricing methodology* submitted in January 2022 to address the changes required by the introduction of System Strength Charging in accordance with the AEMC's Rule determination, Efficient Management of System Strength on the Power System Rule 2021, October 2021.

13. Additional Information Requirements

A number of additional information requirements arise from the *pricing methodology guidelines* which have not been covered elsewhere in this proposed *pricing methodology*. In order to satisfy these requirements ElectraNet notes that it does not:

- consider transitional arrangements are necessary as a result of the implementation of the proposed *pricing methodology*;
- have any applicable relevant *derogations* in accordance with chapter 9 of the Rules; or
- have any applicable transitional arrangements arising from chapter 11 of the Rules.

ElectraNet has not provided a confidential version of this proposed *pricing methodology* to the AER in accordance with clause 2.5 of the *pricing methodology guidelines* and hence the provisions of clause 2.1(n) of the *pricing methodology guidelines* are not applicable.

14. Conclusion

ElectraNet's revised proposed *pricing methodology* for the *regulatory control period* from 1 July 2023 to 30 June 2028 has been submitted to the AER in accordance with the requirements of Chapter 6A of the Rules and the *pricing methodology guidelines*.

ElectraNet is confident that this proposed *pricing methodology* fully satisfies the requirements of the Rules and the *pricing methodology guidelines*.



Revised Proposed Pricing Methodology

Appendices

2 December 2022

Appendix A Structure of Transmission Pricing under Part J of Chapter 6A of Rules

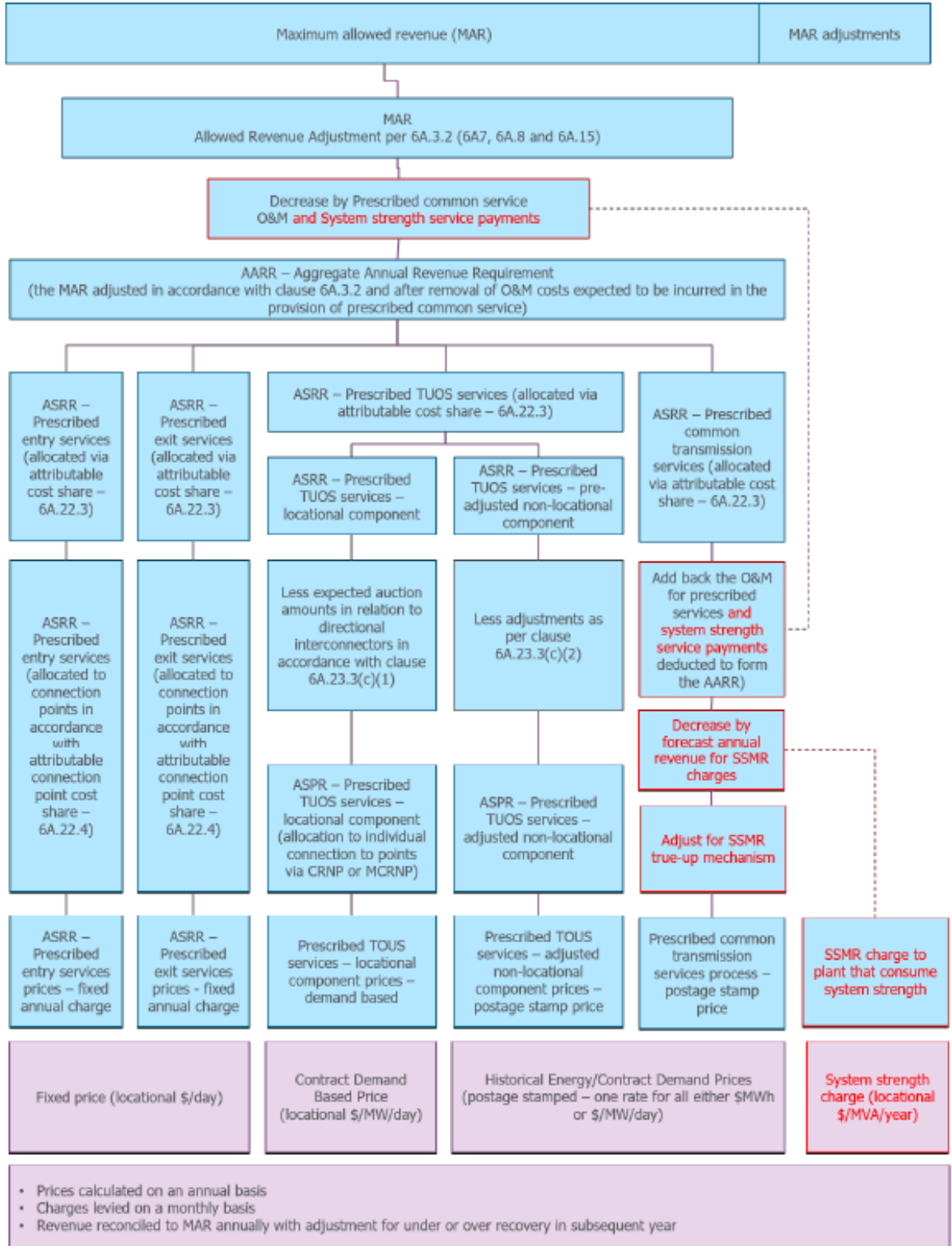

Appendix B Details of Cost Allocation Process

A detailed cost allocation process is used to assign the optimised replacement cost (**ORC**) of all *prescribed transmission service* assets to either *prescribed common transmission services* (assets that benefit all *Transmission Customers*), *network branches* (*transmission lines* or *transformers*)²¹ and *prescribed entry services* or *prescribed exit services* in a manner consistent with Section 2.4 of the *pricing methodology guidelines*.

Consistent with Clause S6A.3.2(1) of the Rules the ORC of non-*prescribed transmission system* assets that are *designated network assets* or *identified user shared assets* is zero.

The cost allocation process is summarised as follows:

Step 1: Initial Cost Allocation

Assets and their ORCs are assigned to one of the following primary asset categories:

- transmission lines;
- transformers;
- circuit breakers;
- common service assets (communications, reactive support, office buildings etc.); and
- *substation* local assets (ancillary equipment, civil work, and establishment).

The following plant items are not separately identified in the ORC database and are incorporated into the ORC of the associated primary items above:

- bus work;
- secondary systems including protection and instrument transformers.

Step 2: Allocation to Categories of Transmission Services

Assets are allocated to the *categories of prescribed transmission services* in accordance with the provisions of Section 2.4 of the *pricing methodology guidelines*. In the case of circuit breakers, each circuit breaker has its replacement cost divided evenly between the *network* branches to which it is directly attributable. Any circuit breaker that is not directly attributable to any *network* branch together with *substation* local costs identified in Step 1 are subject to the priority ordering process.

In the case of a shared *connection asset*, such as a *transformer*, serving multiple *connection points* which may provide both *prescribed entry services* and *prescribed exit services* the cost of the shared *connection asset* will be allocated to the appropriate category or categories of *prescribed transmission services* using an appropriate cost allocator²². For example:

- *Generation* or reactive plant nameplate rating capacity or contract agreed maximum demand supplied by the specified transmission *category of prescribed transmission services* as a percentage of the total capacity and demand of all categories of *prescribed transmission services* at that location: - Costs are attributable based on the capacity and/or contract agreed maximum demand agreed upon by the *Transmission Customer(s)*;

²¹ ElectraNet maintains an ORC model of the *transmission network* to determine the appropriate ORC of individual *transmission lines*, *transformers*, circuit breakers, *common service* assets and *substation* local costs.

²² This is consistent with ElectraNet's proposed *Cost Allocation Methodology* which is used to allocate costs between *prescribed transmission services*, *negotiated transmission services* and *non-regulated transmission services*.

- Unit of plant method: - Costs are allocated based on the number of units of plant installed (typically circuit breakers) where these units of plant can be attributed to a particular *category of prescribed transmission service*; or
- As negotiated between the connecting parties.

This process would also be adopted to allocate shared costs to individual *connection points*.

Step 3: Priority Ordering

In the case of those costs which would be attributable to more than one category of *prescribed transmission services*, specifically the *substation* local assets identified in Step 1 and those circuit breakers identified as *substation* local costs in Step 2, costs will be allocated in accordance with the provisions of clause 6A.23.2(d) of the Rules having regard to the *stand-alone amount* costs associated with the provision of *prescribed TUOS services* and *prescribed common transmission services* with the remainder being allocated to *prescribed entry services* and *prescribed exit services*. The implementation of the priority ordering process is detailed in Appendix E.

Conclusion

The shared *network* costs resulting from the cost allocation process are used as input to TPRICE, the *cost reflective network pricing* software that is approved by the AER for use by TNSPs in the *NEM*.

The entry cost, exit cost and common service costs are used as input to the calculation of *prescribed entry services* prices, *prescribed exit services* prices and *prescribed common transmission services* prices.

Appendix C Cost Reflective Network Pricing Methodology

The *cost reflective network pricing methodology* (or **CRNP methodology**) involves the following steps:

- Determining the annual costs of the individual *transmission network* assets in the optimised *transmission network*.
- For a *modified CRNP methodology*, adjusting each asset's cost according to its expected utilisation.
- Determining the proportion of each individual *transmission element* utilised in providing a *transmission service* to each *connection point* in the *transmission network* for specified operating conditions.
- Determining the maximum flow imposed on each *transmission element* by *load* at each *connection point* over a set of operating conditions.
- Allocating the costs attributed to the individual *transmission elements* to *loads* based on the proportionate use of the *transmission elements*.
- Determining the total cost (lump sum) allocated to each *connection point* by adding the share of the costs of each individual *transmission network element* attributed to each *connection point* in the *transmission network*.

C1 Allocation of Generation to Load

A major assumption in the use of the *CRNP methodology* is the definition of the *generation* source and the point where *load* is taken. The approach is to use the "electrical distance" to pair *generation* to *load*, in which a greater proportion of *load* at a particular location is supplied by *Generators* that are electrically closer than those that are electrically remote. In electrical engineering terminology the "electrical distance" is the impedance between the two locations, and this can readily be determined through a standard engineering calculation called the "fault level calculation".

Once the assumption has been made as to the *Generators* that are supplying each *load* for a particular *load* and *generation* condition (time of day) it is possible to trace the flow through the *transmission network* that results from supplying each *load* (or *Generator*). The use made of any *transmission element* by a particular *load* is then simply the ratio of the flow on the *transmission element* resulting from the *supply* to this *load* to the total use of the *load* made by all *loads* and *Generators* in the *power system*.

C2 Operating Conditions for Cost Allocation

The choice of operating conditions is important in developing prices using the *CRNP methodology* or *modified CRNP methodology*. ElectraNet has flexibility in the choice of operating conditions but notes that until 2006 the Rules set out principles that should apply in determining the sample of operating conditions considered. Of particular note is the requirement that the operating conditions to be used are to include at least 10 days with high system demand, to ensure that loading conditions, which impose peak flows on all *transmission elements*, are captured.

Schedule 6A.3.2(3) of the Rules is less prescriptive requiring that the allocation of *dispatched generation* to *loads* be over a range of actual operating conditions from the previous *financial year* and that the range of operating scenarios is chosen so as to include the conditions that result in most stress on the *transmission network* and for which *network* investment may be contemplated.

In selecting those operating scenarios it is important to recognise that the operating conditions that impose most stress on particular *transmission elements* may occur at times other than for system peak demand.

Appendix D Ratings Adjustment for Calculating Utilisation Factors

When assigning a proportion of shared *network* costs to individual *Transmission Customer connection points*, the *modified CRNP methodology* reduces the ORC of each shared *network* pricing branch (line or *transformer*) by a utilisation factor that reflects the maximum loading of the branch with respect to its rating.

In determining the appropriate branch rating for entry into TPRICE (used to perform the *CRNP* calculations) it is important to understand that TPRICE only considers system normal operating conditions whereas the shared *network* must be able to withstand a single contingency *outage* without overloading any *network element* consistent with the requirements of the Rules and the ETC.

This means that utilisation factors calculated with respect to equipment ratings (thermal line ratings and transformer nameplate ratings) under system normal conditions would result in artificially low utilisation factors.

This problem can be overcome by reducing the equipment ratings to reflect the maximum flow on a *network* branch under system normal conditions that would not result in its absolute rating being exceeded in the event of the worst contingency.

The reduced ratings are calculated by examining flows in *transmission elements* over a range of peak system operating conditions first for system normal conditions, and then with each meshed *transmission element* out of service one at a time. For each *transmission element*, the ratio of maximum system normal flow to maximum contingency flow is used to scale down the absolute equipment rating to obtain the reduced rating for input to TPRICE.

This rating adjustment is consistent with Schedule 6.4.1.6(b) of the old Rules, which states in relation to a *modified CRNP methodology* that “*The asset utilisation is to be based on the maximum flow allowed on elements within the normal operating constraints of the network*”.

This process can best be illustrated by an example. A line has an absolute (thermal) rating of 200 MV.A. *Network* analysis over a range of peak operating conditions shows that this line has a maximum system normal flow of 120 MV.A and a maximum single contingency flow of 160 MV.A. The reduced rating of this line (as input to TPRICE) is $(120/160) * 200$ giving 150 MV.A.

When TPRICE is run, analysis will consider flows on this line over a much wider range of operating conditions (than used in the contingency analysis) some of which may even exceed 120 MV.A. If say the highest usage of this line over the operating conditions assessed by TPRICE is 123 MV.A, then the utilisation factor used by TPRICE with *modified CRNP* will be 0.82 (123/150).

Appendix E Priority Ordering Methodology

E1 Rules Requirements

Clause 6A.23.2(d) of the Rules requires that:

Where, as a result of the application of the *attributable cost share*, a portion of the *AARR* would be attributable to more than one *category of prescribed transmission services*, that *attributable cost share* is to be adjusted and applied such that any costs of a *transmission system* asset that would otherwise be attributed to the provision of more than one category of *prescribed transmission services*, is allocated as follows:

- (1) to the provision of *prescribed TUOS services*, but only to the extent of the *stand-alone amount* for that *category of prescribed transmission services*;
- (2) if any portion of the costs of a *transmission system* asset is not allocated to *prescribed TUOS services*, under subparagraph (1), that portion is to be allocated to *prescribed common transmission services*, but only to the extent of the *stand-alone amount* for that *category of prescribed transmission services*; and
- (3) if any portion of the costs of a *transmission system* asset is not attributed to *prescribed transmission services* under subparagraphs (1) and (2), that portion is to be attributed to *prescribed entry services* and *prescribed exit services*.

Stand-alone amount is defined as:

For a *category of prescribed transmission services*, the costs of a *transmission system* asset that would have been incurred had that *transmission system* asset been developed, exclusively to provide that *category of prescribed transmission services*.

Transitional Rule 11.6.11(c) states the following:

“For the purposes of new Chapter 6A:

- (1) the costs of the *transmission system* assets that from time to time may be treated as:
 - (i) directly attributable to the provision of a prescribed connection service; or
 - (ii) incurred in providing a prescribed connection service,

to a *Transmission Network User* or a group of *Transmission Network Users* at a *transmission network connection point* is limited to the costs of the eligible assets which, from time to time, provide that prescribed connection service;

- (2) any costs of an existing asset or a replacement asset (or of any portion of an existing asset or a replacement asset) that:
- (i) is not an eligible asset (other than as a result of clause 11.6.11(d)); and
 - (ii) is used by a *Transmission Network Service Provider* to provide connection services to a *Transmission Network User* or a group of *Transmission Network Users* at a *transmission network connection point*,
- must be treated as costs that are directly attributable to the provision of, or are incurred in providing, *prescribed TUOS services* and, to avoid doubt, the services provided by those assets which would otherwise be *connection services* are taken to be *prescribed TUOS services*; and
- (3) the *stand-alone amount* for *prescribed TUOS services* is taken to include any portion of the costs referred to in clause 11.6.11(c)(2) that has not been allocated under clause 6A.23.2(d)(1).”

This transitional provision effectively introduces a fourth step to the priority ordering requirement.

E2 Objective and General Approach

The allocation methodology relies on the assumption that *substation* infrastructure and establishment costs are proportionate to the number of *high voltage* circuit breakers in the *substation*.

Based on this assumption the appropriate allocator for *substation* infrastructure and establishment costs for a stand-alone arrangement is the ratio of the number of *high voltage* circuit breakers²³ in the stand-alone arrangement to the number of *high voltage* circuit breakers in the whole *substation*.

E3 Proposed Methodology

Step 1: Branch Identification

Identify the branches²⁴, being the lines, *transformers*, major reactive devices and exits/entries in the *substation* which provide *prescribed TUOS services*, *prescribed common transmission services* and *prescribed exit services* or *prescribed entry services*, in the *substation*.

Step 2: Allocation of Circuit Breakers to Branches

For each *high voltage* circuit breaker in the *substation* identify the branches directly *connected* to it. Any circuit breaker that does not directly *connect* to a branch is excluded from allocation and all costs associated with it are added to the *substation* infrastructure and establishment cost.

Count the total number of circuit breakers directly *connected* to branches.

DNSPs are classified as a *prescribed exit service* while *Generators* are classified as a *prescribed entry service*. *Negotiated transmission services* are not part of the regulated asset base and fall outside the priority ordering process detailed in clause 6A.23.2(d) of the Rules.

²³ Low voltage circuit breakers are not considered in the standalone arrangements.

²⁴ Described in Definition – Branches.

Step 3.1 Stand-alone arrangements for *prescribed TUOS services*

With reference to the number of lines providing *prescribed TUOS services* determine the number of circuit breakers required to provide *prescribed TUOS services* of an equivalent standard on a stand-alone basis²⁵. The stand-alone configuration is the simplest *substation* configuration (in the absence of development) had it been developed to provide a *prescribed TUOS service*. This may be done by way of a look up of typical stand-alone configurations.

Step 3.2 Stand-alone arrangements for *prescribed common transmission services*

With reference to the number of lines providing *prescribed TUOS services* and the devices providing *prescribed common transmission services* determine the number of circuit breakers required to provide *prescribed common transmission services* of an equivalent standard on a stand-alone basis. The stand-alone configuration is the simplest *substation* configuration (in the absence of development) had it been developed to provide a *prescribed common transmission service*. This may be done by way of a look up of typical stand-alone configurations.

Step 4: Allocation of *substation* infrastructure and establishment costs

Step 4.1 Allocation of *prescribed TUOS services*

Allocate a portion of *substation* infrastructure and establishment costs to *prescribed TUOS services* according to the ratio of the *high voltage* circuit breakers identified in Step 3.1 to the total number of *high voltage* circuit breakers *connected* to branches in the *substation* identified in Step 2.

Step 4.2 Calculation of the Unallocated *Substation* Infrastructure Costs (after *prescribed TUOS service allocation*)

Calculate the unallocated *substation* infrastructure cost (after *prescribed TUOS services* allocation) by subtracting the amount calculated in Step 4.1 from the total *substation* infrastructure amount.

Step 4.3 Allocation of *prescribed common transmission service*

Allocate a portion of the *substation* infrastructure and establishment costs to *prescribed common transmission services* based on to the ratio of the *high voltage* circuit breakers providing *prescribed common transmission services* identified in Step 3.2 to the total number of *high voltage* circuit breakers *connected* to branches in the *substation*. If the *prescribed common transmission services* portion of *substation* infrastructure is greater than the unallocated costs, then the unallocated portion only is attributed to *prescribed common transmission services*. In this instance, nothing will be attributed to *prescribed entry services* and *prescribed exit services*.

25 A substation would typically not exist to provide prescribed TUOS services alone, however this interpretation is inconsistent with the intent of the Rule. Accordingly, standalone arrangements for prescribed TUOS services are taken to require a level of switching consistent with the prevailing bus arrangements.

Step 4.4 Calculation of the Unallocated Substation Infrastructure Costs (after prescribed common transmission service allocation)

Calculate the unallocated *substation* infrastructure cost (after *prescribed common transmission services* allocation) by subtracting the amount calculated in Step 4.3 from the amount calculated in Step 4.2.

Step 4.5 Allocation of prescribed entry service and prescribed exit service costs to prescribed TUOS services per clause 11.6.11 of the Rules

Allocate the remaining *substation* infrastructure and establishment costs (calculated in Step 4.4) to each branch providing *prescribed TUOS services* based on the ratio of the *high voltage* circuit breakers providing the *prescribed TUOS services* to the branch to the total number of *high voltage* circuit breakers providing *prescribed TUOS services* or in accordance with the cost allocation process in Appendix B as appropriate.

Notes

Costs are only allocated in Step 4 until fully allocated.

Consistent with clause 6A.23.2(d)(3) of the Rules it is possible that no costs will be attributed to *prescribed entry services* and *prescribed exit services*.

New and existing *negotiated transmission service* assets are excluded from the analysis as any incremental establishment costs associated with them are taken to be included in the *negotiated transmission services* charges on a causation basis.

The assessment of stand-alone arrangements only needs to be conducted once per *substation* except where changes to the configuration of the *substation* occur.

E4 Definition – Branches

As illustrated by the diagrams below a “Branch” is a collection of assets (e.g. lines, circuit breakers, capacitors, buses and *transformers*) that provide a *transmission service*.

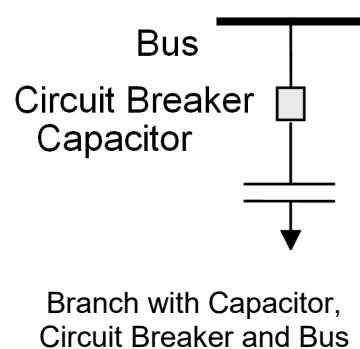
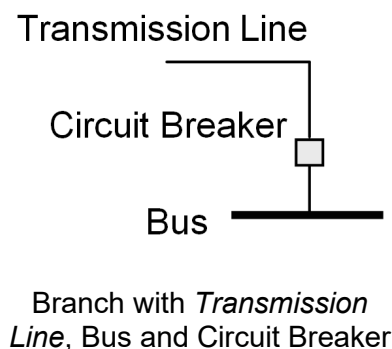

E5 Examples

Example A

Substation Configuration

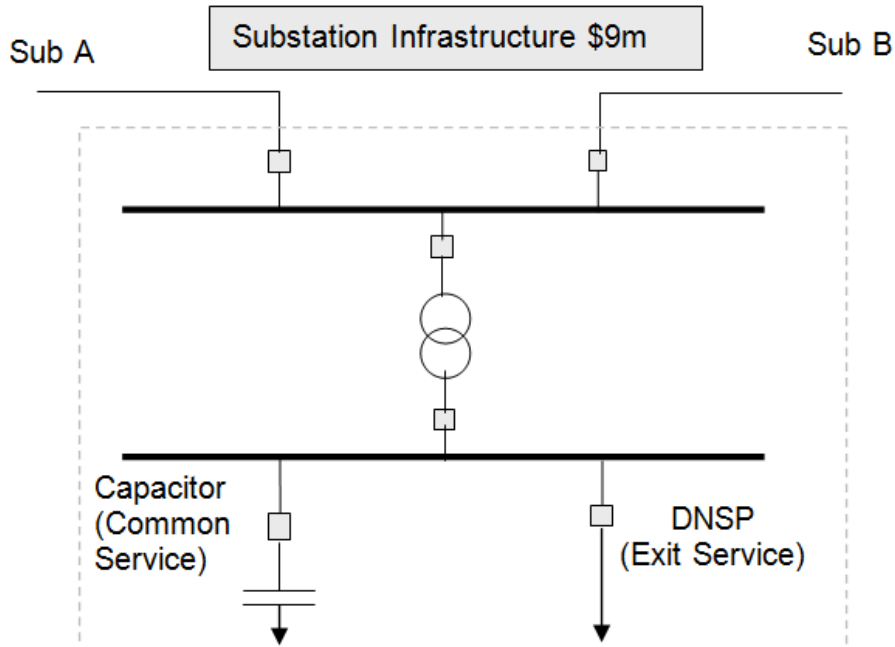

- Step 1: The branches are Sub A, Sub B, DNSP, Tie Transformer and *prescribed common transmission services*.
- Step 2: The total number of circuit breakers directly *connected* to branches is 6.
- Step 3.1: The stand-alone arrangement for the provision of *prescribed TUOS services* to an equivalent standard is shown below and consists of 2 circuit breakers.

Stand-Alone Prescribed TUOS Service



- Step 3.2: The stand-alone arrangement for the provision of *prescribed common transmission services* to an equivalent standard is shown below and consists of 3 circuit breakers.

Stand Alone Prescribed Common Transmission Service

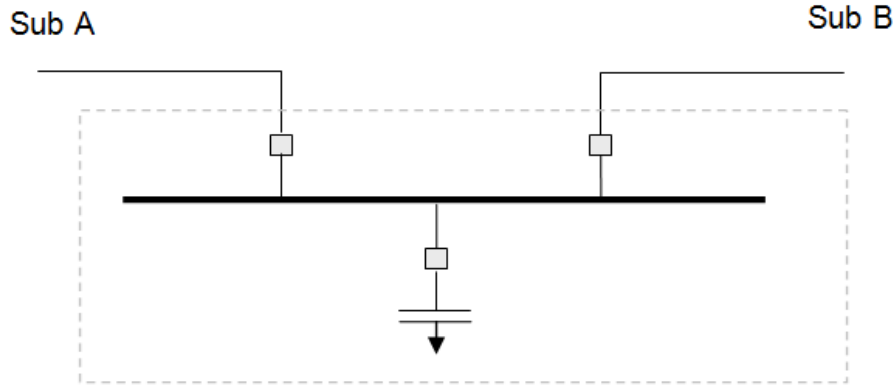

Step 4:

Assume total Infrastructure cost is \$9m.

Costs are allocated to *prescribed TUOS services* in the ratio of the circuit breakers in the stand-alone arrangement to the total circuit breakers.

Infrastructure Cost Allocated to *prescribed TUOS services* = $(2/6) \times \$9m = \$3m$

Unallocated *Substation* Infrastructure Costs (after *prescribed TUOS services* allocation) = $\$9m - \$3m = \$6m$

Costs are allocated to *prescribed common transmission services* in the ratio of the circuit breakers in the stand-alone arrangement to the total circuit breakers.

Infrastructure Cost allocated to *prescribed common transmission services* = $(3/6) \times \$9m = \$4.5m$

Unallocated *Substation* Infrastructure Costs (after *prescribed common transmission service* allocation)
= $\$6m - \$4.5m = \$1.5m$

Remainder of unallocated (calculated above) to be allocated to *prescribed TUOS services* per clause 11.6.11 of the Rules

Infrastructure Cost allocated to *prescribed TUOS services* = \$1.5m

Item	Number	Allocation	Unallocated
<i>Substation</i> infrastructure costs		9,000,000	9,000,000
Total Breakers	6		
TUOS Stand-alone breakers	2		
Share to TUOS (a)	0.333	3,000,000	6,000,000
Common Service stand-alone breakers	3		
Share to Common Service	0.500	4,500,000	1,500,000
Share to TUOS (b)		1,500,000	
Total Share to TUOS (a) + (b)		4,500,000	
Total Share to Common Service		4,500,000	

Example B

Substation Configuration

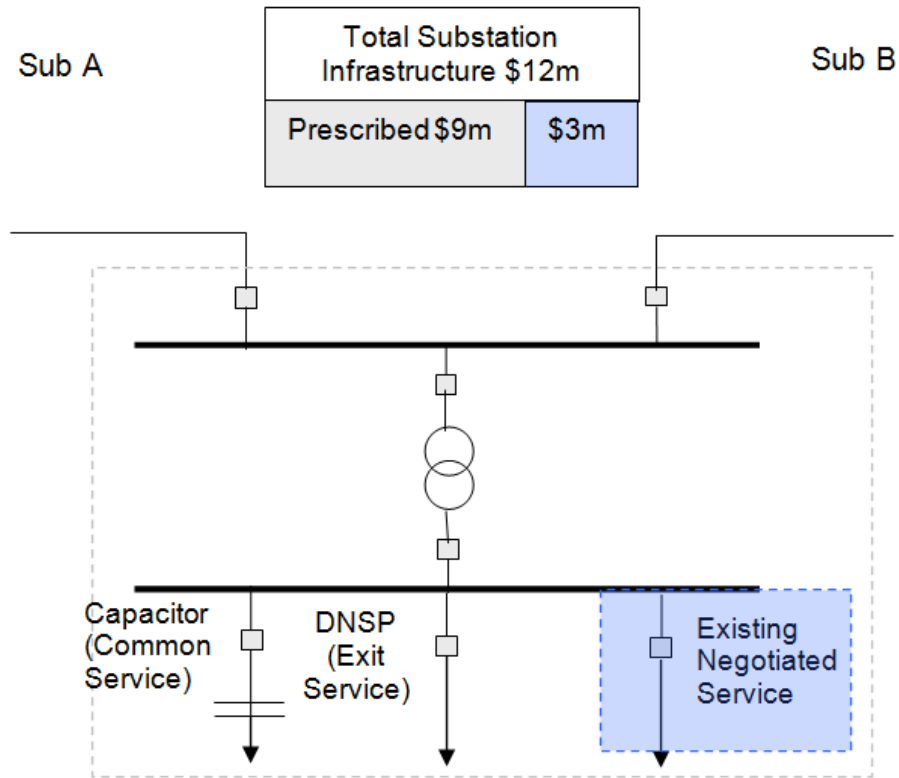

- Step 1: The branches are Sub A, Sub B, DNSP, Tie Transformer, *prescribed common transmission services* and an existing *negotiated transmission service*.
- Step 2: The total number of circuit breakers directly *connected* to branches is 6 (no prescribed costs are allocated to the existing *negotiated transmission service*).
- Step 3.1: The stand-alone arrangement for the provision of *prescribed TUOS services* to an equivalent standard is shown below and consists of 2 circuit breakers.

Stand Alone Prescribed TUOS Services



- Step 3.2: The stand-alone arrangement for the provision of *prescribed common transmission services* to an equivalent standard is shown below and consists of 3 circuit breakers.

Stand Alone Prescribed Common Transmission Services

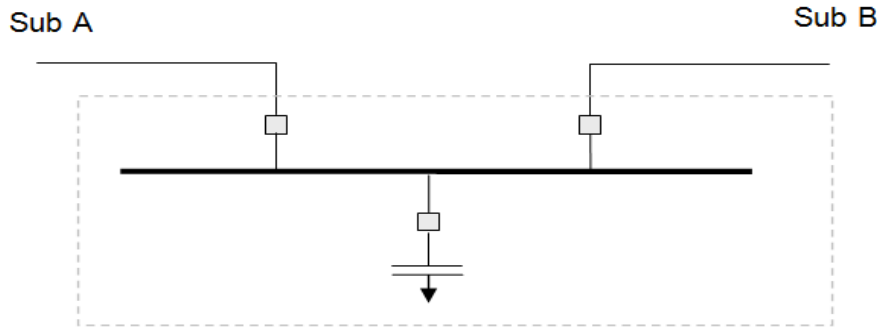

Step 4:

Assume total Infrastructure cost is \$12m, however \$3m is for the existing *negotiated transmission service*, which does not form part of the regulated asset base and is not governed by clause 6A.23.2(d) of the Rules.

Costs are allocated to *prescribed TUOS services* in the ratio of the circuit breakers in the stand-alone arrangement to the total circuit breakers.

Infrastructure Cost Allocated to *prescribed TUOS services* = $(2/6) \times \$9m = \$3m$

Unallocated *Substation* Infrastructure Costs (after *prescribed TUOS services* allocation) = $\$9m - \$3m = \$6m$

Costs are allocated to *prescribed common transmission services* in the ratio of the circuit breakers in the stand-alone arrangement to the total circuit breakers.

Infrastructure Cost allocated to *prescribed common transmission services* = $(3/6) \times \$9m = \$4.5m$

Unallocated *Substation* Infrastructure Costs (after *prescribed common transmission services* allocation)
= $\$6m - \$4.5m = \$1.5m$

Remainder of unallocated (calculated above) to be allocated to *prescribed TUOS services*.

Infrastructure Cost allocated to *prescribed TUOS services* = \$1.5m

Item	Number	Allocation	Unallocated
Substation infrastructure costs		9,000,000	9,000,000
Total Breakers	6		
TUOS Stand-alone breakers	2		
Share to TUOS (a)	0.333	3,000,000	6,000,000
Common Service stand-alone breakers	3		
Share to Common Service	0.500	4,500,000	1,500,000
Share to TUOS (b)		1,500,000	
Total Share to TUOS		4,500,000	
Total Share to Common Service		4,500,000	

Example C

Substation Configuration

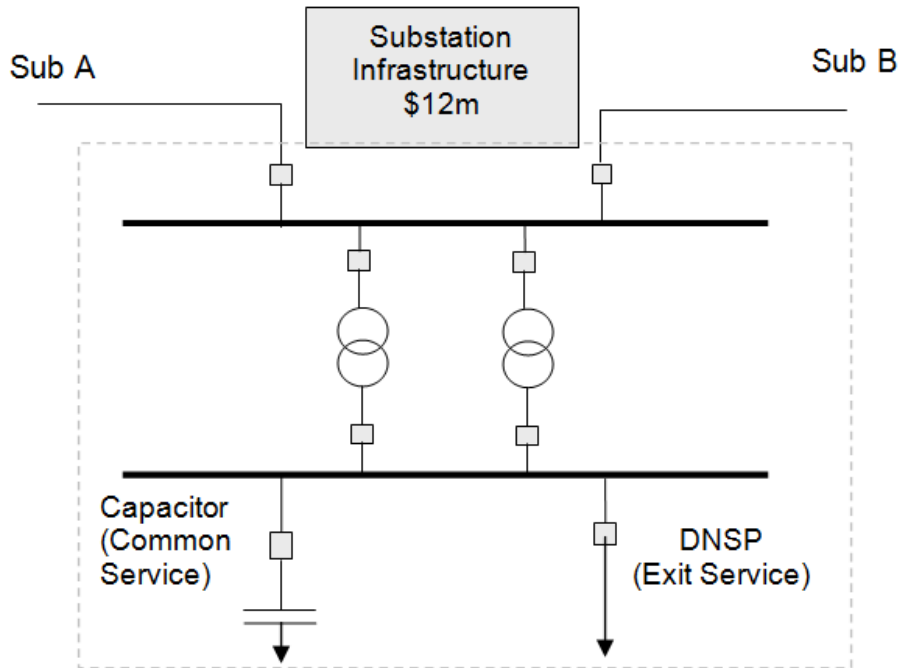

- Step 1: The branches are Sub A, Sub B, DNSP, Tie Transformer 1, Tie Transformer 2 and *prescribed common transmission service*.
- Step 2: The total number of circuit breakers directly *connected* to branches is 8.
- Step 3.1: The stand-alone arrangement for the provision of *prescribed TUOS services* to an equivalent standard is shown below and consists of 2 circuit breakers.

Stand Alone Prescribed TUOS services



- Step 3.2: The stand-alone arrangement for the provision of *prescribed common transmission services* to an equivalent standard is shown below and consists of 3 circuit breakers.

Stand Alone Prescribed Common Transmission Service

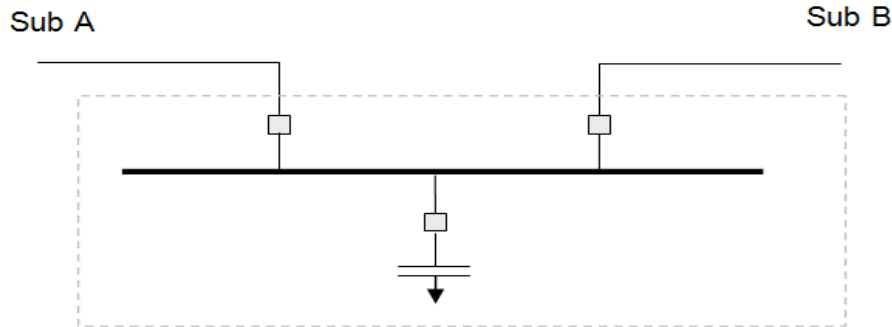

Step 4:

Assume total Infrastructure cost is \$12m.

Costs are allocated to *prescribed TUOS services* in the ratio of the circuit breakers in the stand-alone arrangement to the total circuit breakers.

Infrastructure Cost Allocated to *prescribed TUOS services* (a) = $(2/8) \times \$12m = \$3m$

Unallocated *Substation* Infrastructure Costs (after *prescribed TUOS services* allocation) = $\$12m - \$3m = \$9m$

Costs are allocated to *prescribed common transmission service* in the ratio of the circuit breakers in the stand-alone arrangement to the total circuit breakers.

Infrastructure Cost allocated to *prescribed common transmission services* = $(3/8) \times \$12m = \$4.5m$

Unallocated *Substation* Infrastructure Costs (after *prescribed common transmission services* allocation)
= $\$9m - \$4.5m = \$4.5m$

Remainder of unallocated (calculated above) to be allocated to *prescribed TUOS services*.

Infrastructure Cost allocated to *prescribed TUOS services* (b) = \$4.5m

Item	Number	Allocation	Unallocated
Substation infrastructure costs		12,000,000	12,000,000
Total Breakers	8		
TUOS Stand-alone breakers	2		
Share to TUOS (a)	0.250	3,000,000	9,000,000
Common Service stand-alone breakers	3		
Share to Common Service	0.375	4,500,000	4,500,000
Share to TUOS (b)		4,500,000	
Total Share to TUOS		7,500,000	
Total Share to Common Service		4,500,000	

Example D

Substation Configuration

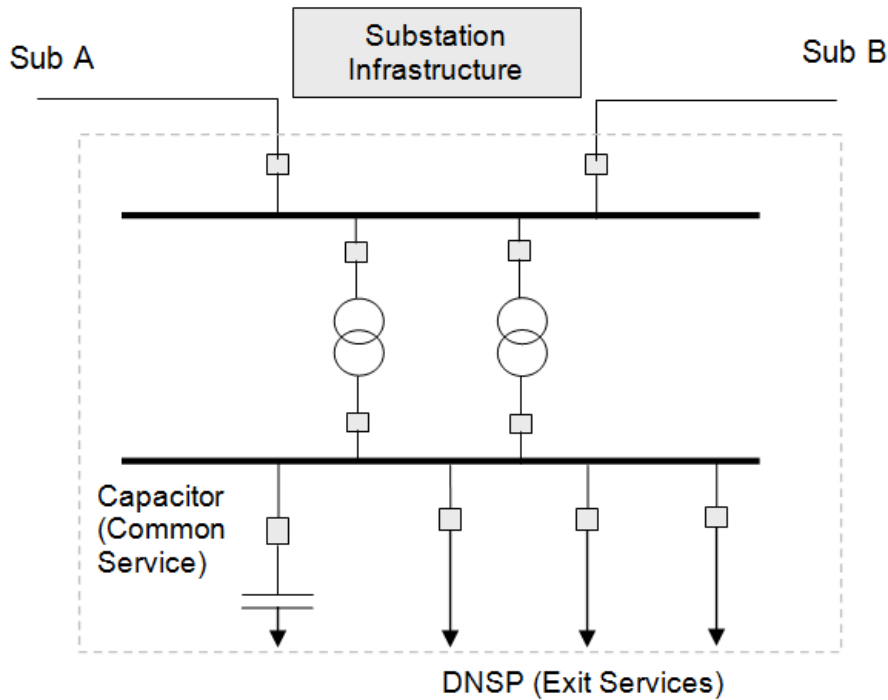

- Step 1: The branches are Sub A, Sub B, *DN*SP1, *DN*SP2, *DN*SP3, Tie Transformer 1, Tie Transformer 2 and PCS.
- Step 2: The total number of circuit breakers directly *connected* to branches is 10.
- Step 3.1: The stand-alone arrangement for the provision of *prescribed TUOS services* to an equivalent standard is shown below and consists of 2 circuit breakers.

Stand Alone Prescribed TUOS services



- Step 3.2: The stand-alone arrangement for the provision of *prescribed common transmission services* to an equivalent standard is shown below and consists of 3 circuit breakers.

Stand Alone Prescribed Common Transmission Service

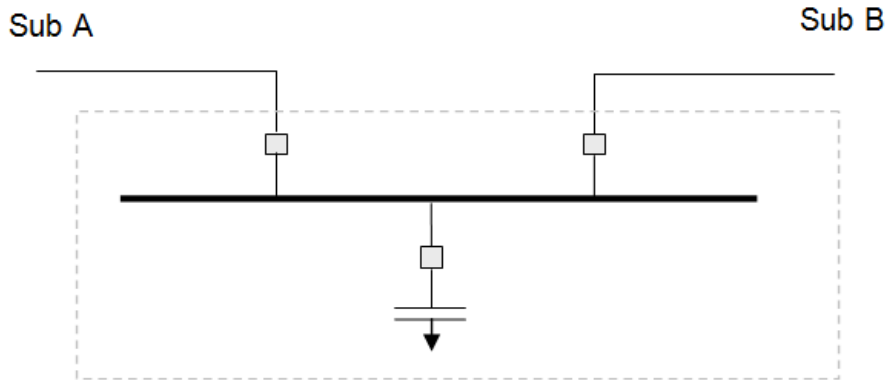

Step 4:

Assume total Infrastructure cost is \$15m.

Costs are allocated to *prescribed TUOS services* in the ratio of the circuit breakers in the stand-alone arrangement to the total circuit breakers.

Infrastructure Cost Allocated to *prescribed TUOS services* (a) = $(2/10) \times \$15m = \$3m$

Unallocated *Substation* Infrastructure Costs (after *prescribed TUOS services* allocation) = $\$15m - \$3m = \$12m$

Costs are allocated to *prescribed common transmission services* in the ratio of the circuit breakers in the stand-alone arrangement to the total circuit breakers.

Infrastructure Cost allocated to *prescribed common transmission service* = $(3/10) \times \$15m = \$4.5m$

Unallocated *Substation* Infrastructure Costs (after *prescribed TUOS services* allocation) = $\$12m - \$4.5m = \$7.5m$

Remainder of unallocated (calculated above) to be allocated to *prescribed TUOS services*.

Infrastructure Cost allocated to *prescribed TUOS services* (b) = \$7.5m

Item	Number	Allocation	Unallocated
Substation infrastructure costs		15,000,000	15,000,000
Total Breakers	10		
TUOS Stand-alone breakers	2		
Share to TUOS (a)	0.200	3,000,000	12,000,000
Common Service stand-alone breakers	3		
Share to Common Service	0.300	4,500,000	7,500,000
Share to TUOS (b)		7,500,000	
Total Share to TUOS		10,500,000	
Total Share to Common Service		4,500,000	

Appendix F Inter-regional Transmission Charging

F1 Introduction

As the appointed *Co-ordinating Network Service Provider (CNSP)* referred to in Clause 6A.29.1 of the Rules, ElectraNet will calculate the *AARR* for the SA region, and will allocate, calculate, bill and arrange for the payment of the *modified load export charge (MLEC)* in accordance with 6A.29A of the Rules and the Section 2.6 of the *pricing methodology guidelines*.

ElectraNet will publish details of all *modified load export charges* to apply in the following *financial year* on its website by 15 February each year consistent with clause 6A.24.2(b) of the Rules.

The *inter-regional transmission* charging arrangement allows *TNSPs* to levy a *modified load export charge* on *TNSPs* in *interconnected regions*. *Transmission Customers* would subsequently pay a share of the costs of *prescribed transmission services* used to import electricity into their *region* from *interconnected regions*.

F2 Overview of the process

An overview of the process to calculate MLEC is shown in the diagram on the following page.

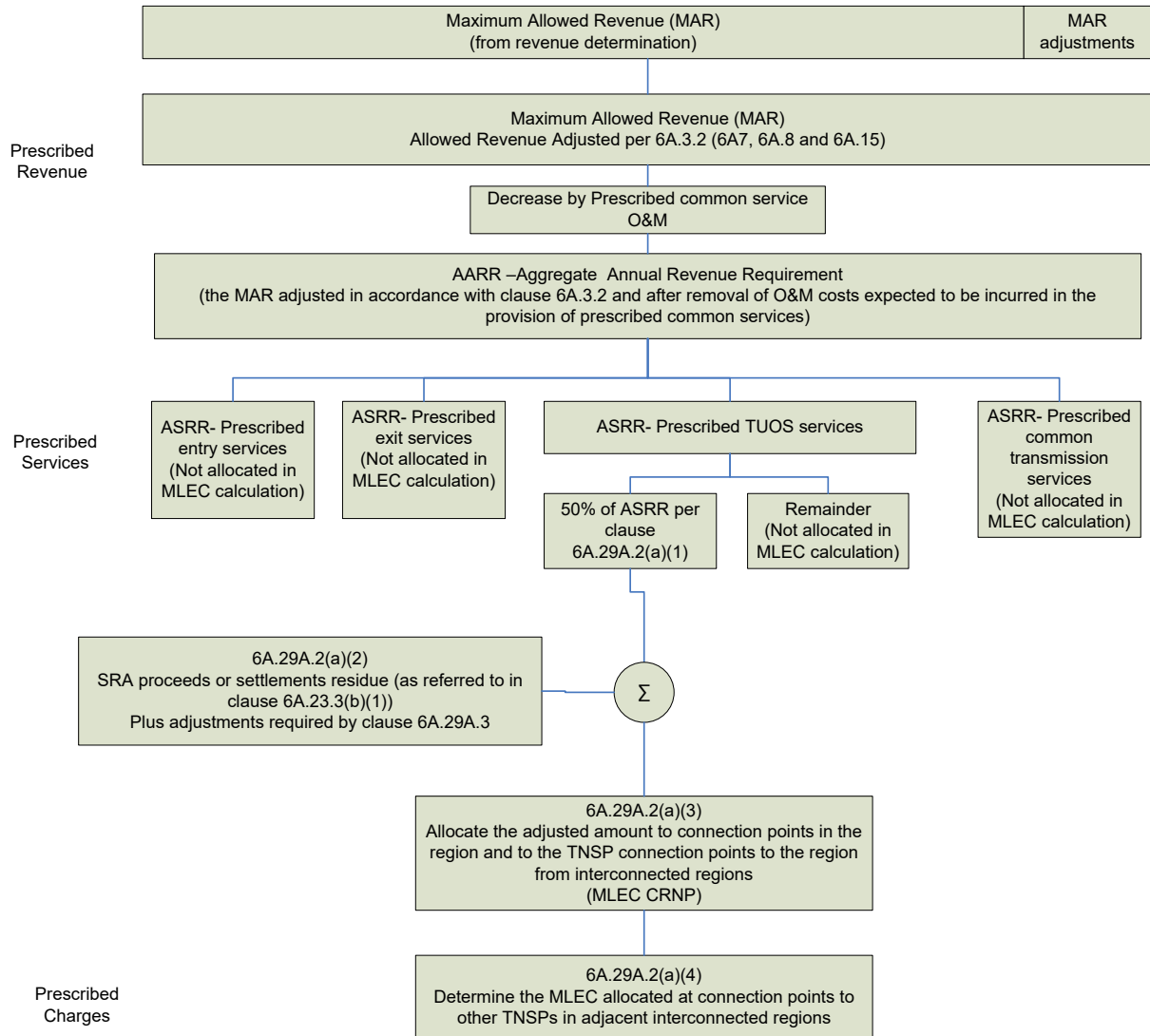

The steps involved to calculate MLEC are:

Step 1:

The *AARR* will be calculated as described in section 7.3 of ElectraNet’s proposed *pricing methodology*.

The allocation of the *AARR* to each of the *categories of prescribed transmission services* will be calculated as described in Sections 7.6 to 7.8 of ElectraNet’s proposed *pricing methodology*. This will determine the *ASRR* to be recovered from *prescribed TUOS services*.

The calculations in Step 1 are the same as for calculating *transmission prices*.

Step 2:

As required by Clause 6A.29A.2(a)(1) of the Rules, the *modified load export charge* is to be calculated from 50% of the *ASRR* for *prescribed TUOS services* for that *financial year*.

Step 3:

The amount determined in Step 2 is the *TUOS* revenue to be recovered on a locational basis and is adjusted in accordance with Clause 6A.29A.2(a)(2) of the Rules by:

- subtracting estimated inter-regional settlements residue auction proceeds;
- subtracting a portion of the *settlements residue* as referred to in clause 6A.23.3(b)(1);
- including any adjustments as required by 6A.29A.3.

Step 4:

Clause 6A.29A.2(a)(3) requires the adjusted amount from Step 3 to be allocated to *connection points* of *Transmission Customers* in the *region* and to *CNSPs interconnected* to the *region* as if they were *connected* as *Transmission Customers*. This allocation will be made on a proportionate use of *transmission system* assets.

Consistent with the requirements of clause 6A.29A.2(a)(3) the MLEC *CRNP methodology* for estimating the proportionate use of the relevant *transmission system* assets will be used.

The MLEC *CRNP methodology* is applied using the T-PRICE *cost reflective network pricing* software used by all TNSPs in the *NEM*.

The *CRNP methodology* requires three sets of input data:

- an electrical (load flow) model of the *network*;
- a cost model of the *network*; and
- a set of *load/generation* patterns.

Appendix C of this *pricing methodology* describes the *CRNP methodology* in more detail.

The *network* model differs slightly from the *network* model used for price determination as described in the proposed *pricing methodology*. The *network* model in the MLEC *CRNP methodology* does not require *inter-regional settlements residue auction* proceeds to be converted into an equivalent asset as described in Section 7.9.3 of the proposed *pricing methodology*.

The MLEC *CRNP methodology* does not require the utilisation adjustments characteristic of *modified CRNP*. The utilisation of *transmission elements* will be set to allocate 100% of system costs to *loads* when applying the MLEC *CRNP methodology*.

The key requirements for MLEC *CRNP methodology* are:

- The MLEC to be determined using standard *CRNP methodology*.
- All *transmission elements* are to be included.
- All half hour periods in the previous full *financial year* are to be used.
- Peak usage of assets must be used.

For each *regulatory year* the MLEC will be calculated using the MLEC *CRNP methodology*. The calculation will use *generation* and *load* data from the previous *financial year* completed at the time the MLEC *CRNP* is being calculated.

Step 5:

Clause 6A.29A.2(a)(4) requires the MLEC to be recovered from CNSPs in *interconnected regions* to be the amount allocated to *connection points* to *interconnected regions* as determined in Step 4.

F3 Timetable for the provision of data

Refer section 6 of the pricing methodology.

F4 Billing the modified load export charge

ElectraNet will issue a monthly bill to the CNSP in each *interconnected region* for the MLEC amount payable to ElectraNet in accordance with clause 6A.29A.4(a) of the Rules. The monthly bills will include any adjustments made to it in accordance with the Rules (Clause 6A.29A.3 of the Rules).

In accordance with clause 6A.29A.4(b) of the Rules, the monthly bill will include:

- The total annual estimate of MLEC payable by the CNSP.
- Details of the MLEC allocation under the *CRNP methodology* and the adjustments as specified in clauses 6A.29A.3 and 6A.23.3(f).
- The monthly instalment amount.

F5 Billing arrangements between multiple TNSPs in a region

Allocation of amounts to each TNSPs in the same region

In accordance with clause 6A.29A.5(a) of the Rules, where there is more than one TNSP in a *region*, the CNSP is required to allocate any amounts receivable by or payable to it for MLEC to each TNSP in accordance with its *pricing methodology*.

As the appointed CNSP referred to in clause 6A.29.1 of the Rules, ElectraNet will allocate any amounts receivable or payable for MLEC to each relevant TNSP in the South Australian *region* for the following *financial year* as required by clause 6A.29A.5 of the Rules.

This allocation will be based on the MLEC *CRNP methodology* for estimating the proportionate use of the relevant *transmission system* assets. The allocation of amounts will be calculated according to *intra-regional*, rather than *inter-regional*, *network* utilisation.

For the avoidance of doubt, these amounts will be incorporated in the *connection point* prices determined by ElectraNet for each TNSP in the South Australian *region*. ElectraNet collects both ElectraNet's and MTC's regulated revenue entitlements via ElectraNet's *prescribed transmission service* prices.

As these prices incorporate the full impact of the MLEC, no net amounts arise under clause 6A.29A.5(a) of the Rules.

Billing each TNSP in the same region

Clause 6A.29A.5(b) of the Rules requires the CNSP to issue bills for the net amounts (allocated in clause 6A.29A.5(a)) receivable by or payable to the CNSP for MLEC to each TNSP in its *region*.

As noted in Section 7.2 of ElectraNet's proposed *pricing methodology*, as the appointed CNSP referred to in clause 6A.29.1 of the Rules ElectraNet collects both ElectraNet's and MTC's regulated revenue entitlements via ElectraNet's *prescribed transmission service prices*.

Notwithstanding these prices incorporating the full impact of the MLEC, bills are required to be issued under clause 6A.29A.5(b) of the Rules.

ElectraNet will issue a bill to each TNSP in the South Australian *region* for the net amount of MLEC as required in clause 6A.29A.5(b) of the Rules to be paid in equal monthly instalments or as documented in revenue collection agreements negotiated between the parties. Such payments will be calculated by ElectraNet. ElectraNet will also provide reasonable details on the calculation of these amounts.

F6 Worked example – modified load export charge

The worked example uses the same amounts referred to in the examples of the proposed *pricing methodology*.

Step 1 – Aggregate annual revenue requirement (AARR)

In accordance with clause 6A.22.1 of the Rules, the *maximum allowed revenue* is adjusted:

- in accordance with clause 6A.3.2 of the Rules; and
- by subtracting the operating and maintenance costs expected to be incurred in the provision of *prescribed common transmission services*; and
- by any allocation as agreed between TNSPs in accordance with clause 6A.29.3 of the Rules.

This example assumes that the *maximum allowed revenue* is \$2,604,434.

Table 9: Derivation of AARR to be allocated to the four services

Derivation	Amount (\$)
<i>Maximum allowed revenue</i>	2,604,434
Total adjustments for: <ul style="list-style-type: none"> • network support pass through; • cost pass through; • payments or penalties under the <i>service target performance incentive scheme</i>; and • <i>contingent projects</i>. 	- 45,000
Deduct operating and maintenance expenditure (incurred in the provision of <i>prescribed common services</i>) and expected system strength service payments	-55,000
AARR to be allocated	2,504,434

Step 2 – Annual service revenue requirement

Similar to the calculation example in 7.2 of the proposed *pricing methodology*, the *ASRR* for each *category of prescribed transmission service* is calculated as shown in Table 10 below.

Table 10: Asset allocations to categories of prescribed transmission services

Category	Asset Value (\$)	Cost Share
<i>Prescribed exit service</i>	6,972,222	16.2%
<i>Prescribed entry service</i>	1,761,111	4.1%
<i>Prescribed TUOS service</i>	33,566,667	78.0%
<i>Prescribed common transmission service</i>	750,000	1.7%
Total	43,050,000	100.0%

The cost share percentages shown in Table 10 above are used to allocate the revenue to be recovered from each *category of prescribed transmission services*. In accordance with the adjustments set out in Table 9, Table 11 shows that the revenue to be allocated (the *AARR*) is \$2,504,434.

Table 11: Calculation of ASRR

Category	Cost Share	<i>AARR</i> to be recovered from each service (\$)
<i>Prescribed exit service</i>	16.2%	405,609
<i>Prescribed entry service</i>	4.1%	102,453
<i>Prescribed TUOS service</i>	78.0%	1,952,741
<i>Prescribed common transmission service</i>	1.7%	43,631
Total	100.0%	2,504,434

Clause 6A.29A.2(a)(1) then requires 50% of the *ASRR* for *prescribed TUOS services* to be calculated.

Category	Asset Value (\$)
50% of <i>prescribed TUOS service</i>	976,371

Step 3 – Adjustment for *settlement residue auction* proceeds

For this example, the *inter-regional settlements residue auction* proceeds and other adjustments are assumed to be zero.

Step 4 – Standard *modified load export charge CRNP methodology* calculation

An electrical model of the South Australian *transmission network* is set up including all *transmission elements*. The TPRICE software is used to calculate the allocation of costs based on a proportionate use of *transmission system assets*.

The total allocation to each *connection point* to another *region* is then determined.

Table 12: Standard CRNP methodology allocation and I/C cost share

Connection Point	CRNP ORC Allocation (\$k)	Cost Share
Region 1 – Connection Point 1	1,000	3%
Region 1 – Connection Point 2	300	1%
Region 1 – Connection Point 3	500	1%
Region 2 – Connection Point 1	600	2%
Region 2 – Connection Point 2	400	1%
Total for I/C connection points	2,800	8%
Total for all connection points	33,566,667	

Step 5 – Modified load export charge to be recovered

The revenue to be recovered is pro-rated using the adjusted *AARR* from Step 2.

Table 13: Modified load export charge

Connection Point	Cost Share	Revenue to be recovered from each connection point (\$)
Region 1 – Connection Point 1	3%	29,087
Region 1 – Connection Point 2	1%	8,726
Region 1 – Connection Point 3	1%	14,543
Modified load export charge for Region 1		52,356
Region 2 – Connection Point 1	2%	17,452
Region 2 – Connection Point 2	1%	11,635
Modified load export charge for Region 2		29,089

Appendix G - System Strength Charges

The AER's explanatory statement explained that:²⁶

1. A system strength provider's proposed methodology for setting the System Strength Unit Price (SSUP) must be based on the long run average cost (LRAC) of providing *system strength services* at each *system strength node*;
2. *System strength providers* must use a period of at least 10 years when forecasting long run costs; and
3. If the unit price is updated for indexation each year, the basis for indexation must be consistent with the approach for inflation indexation of the transmission network's maximum allowed revenue under its revenue determination.

As explained in this pricing methodology, our proposed approach to setting System Strength Charges complies with these requirements.

The purpose of this Appendix G is to provide illustrative numerical examples to show how the pricing methodology may apply in the following cases:

4. Case 1: LRAC set for 10 year period, using a combination of network and non-network solutions; and
5. Case 2: As per Case 1, with SSUP reset for years 6-15 with existing network solutions no longer reflecting the forward-looking costs.

In both cases, the SSUP calculates the LRAC over a 10 year period. The examples illustrate how the SSUP may change depending on whether the actual costs of the network solution are higher or lower than the forward-looking costs.

It should be noted that while the focus is on network solutions in these examples, the same approach may apply to non-network solutions where 'locked in' contracts for non-network services no longer reflect the forward-looking costs of providing *system strength services*.

²⁶ AER, Explanatory statement, Final decision - Pricing methodology guidelines: System strength pricing 25 August 2022, page 5.

Case 1 LRAC set based on 10 year forecasts, using combination of network and non-network solutions (All dollar amounts are stated in real terms)

	Year	1	2	3	4	5	6	7	8	9	10	Total
Row 1	Total System Strength requirement (MVA)	1000	1000	1200	1200	1500	1500	1600	1600	1800	1800	14200
Row 2	Requirement met by network solutions (MVA)	500	500	500	500	1000	1000	1000	1000	1000	1000	
Row 3	Annual unit cost of network solutions (\$/MVA)	\$7,400	\$7,400	\$7,400	\$7,400	\$7,400	\$7,400	\$7,400	\$7,400	\$7,400	\$7,400	
Row 4	Annual total cost of network solutions (\$M)	\$3.7	\$3.7	\$3.7	\$3.7	\$7.4	\$7.4	\$7.4	\$7.4	\$7.4	\$7.4	\$59.2
Row 5	Requirement met by non-network solutions (MVA)	500	500	700	700	500	500	600	600	800	800	
Row 6	Annual unit cost of non-network solutions (\$/MVA)	\$8,400	\$8,200	\$8,286	\$8,214	\$8,000	\$7,900	\$7,833	\$7,667	\$7,625	\$7,500	
Row 7	Annual total cost of non-network solutions (\$M)	\$4.2	\$4.1	\$5.8	\$5.8	\$4.0	\$4.0	\$4.7	\$4.6	\$6.1	\$6.0	\$49.2
Row 8	Total annual cost of meeting requirement (\$M)	\$7.9	\$7.8	\$9.5	\$9.5	\$11.4	\$11.4	\$12.1	\$12.0	\$13.5	\$13.4	\$108.4

SSUP is the 10-year LRAC, which is \$7,634 per MVA
This price applies for years 1-5 and will be revisited for year 6 onwards

Row 1 shows the total system strength requirement in MVA for each year, as specified by AEMO. To simplify the exposition, this example assumes that the total system strength requirement at the node is the same as the total system strength hosting capacity (SSQ x SSL) at each of the connection points served by that node. In practice, however, the sum of the total system strength hosting capacity at the connection points may exceed the total system strength requirement at the node.

In this example, the TNSP has determined that the most economic mix of resources that will meet the requirement consists of a combination of network and non-network solutions. Row 2 shows the total system strength requirement that will be met by network solutions for each year. This information is provided to illustrate the implied \$/MVA cost for the network and non-network solutions, noting that the System Strength Service Provider will plan to meet the system strength standard at the lowest total life cycle cost.

Row 3 shows the real annual cost per MVA of the network solutions for each year. The annual cost will reflect the expected economic life of the network solution.

Row 4 shows the total annual cost (in real terms) of the network solutions. It is calculated by multiplying the values in Row 2 (MVA provided by network solutions) and Row 3 (real annual cost of network solutions per MVA) for each year.

Row 5 shows the total system strength requirement in MVA to be met by non-network solutions. In each year, the amount of *system strength service* provided by non-network solutions is the difference between the total requirement and the amount provide by the network solutions.

Row 6 shows the forecast real cost of non-network solutions per unit of MVA provided in each year.

Row 7 shows the total annual cost (in real dollars) of the non-network solutions. It is calculated by multiplying the values in Row 5 (MVA provided by non-network solutions) and Row 6 (real annual cost of non-network solutions per MVA) for each year.

Row 8 shows the total annual cost of meeting the specified system strength requirement. It is calculated by summing the values in Row 4 and Row 7.

The long run average cost of meeting the specified system strength requirements is \$7,634 per MVA. It is calculated by summing the total annual cost over 10 years shown in Row 8 (\$108.4 million) and dividing that number by the sum of the total MVA of system strength services provided over the period (14,200 MVA, as shown in Row 1). As noted above, to simplify the exposition, it is assumed that the total system strength hosting capacity is the same as the system strength capacity provided at the node. In practice, the long run average cost would divide the total cost over 10 years by the total system strength hosting capacity.

The table below (Case 2) illustrates the pricing methodology at the first re-set at the end of year 5, where the forward-looking costs are lower than the actual network costs. The greyed out data does not feature in this SSUP calculation in this case.

Case 2 as per Case 1, with SSUP reset for years 6-15 with existing network solutions no longer reflecting the forward-looking costs (All dollar amounts are stated in real terms)

	Year	1	2	3	4	5	6	7	8	9	10	11	12	13	14	15	Total years 6-15
Row 1	Total System Strength requirement (MVA)	1000	1000	1200	1200	1500	1500	1600	1600	1800	1800	1800	2000	2300	2300	2300	19000
Row 2	Requirement met by network solutions (MVA)	500	500	500	500	1000	1000	1000	1000	1000	1000	1000	1000	1000	1000	1000	
Row 3	Annual unit cost of network solutions (\$/MVA)	\$7,400	\$7,400	\$7,400	\$7,400	\$7,400	\$7,400	\$7,400	\$7,400	\$7,400	\$7,400	\$7,400	\$7,400	\$7,400	\$7,400	\$7,400	
Row 4	Annual total cost of network solutions (\$M)	\$3.7	\$3.7	\$3.7	\$3.7	\$7.4	\$7.4	\$7.4	\$7.4	\$7.4	\$7.4	\$7.4	\$7.4	\$7.4	\$7.4	\$7.4	
Row 5	Forward-looking annual unit cost of network solutions (\$/MVA)						\$7,400	\$7,400	\$7,400	\$7,400	\$7,400	\$7,250	\$7,250	\$7,250	\$7,250	\$7,250	
Row 6	Forward-looking annual total cost of network solution (\$M)						\$7.4	\$7.4	\$7.4	\$7.4	\$7.4	\$7.3	\$7.3	\$7.3	\$7.3	\$7.3	\$73.3
Row 7	Requirement met by non-network solution (MVA)	500	500	700	700	500	500	600	600	800	800	800	1000	1300	1300	1300	
Row 8	Annual unit cost of non-network solution (\$/MVA)	\$8,400	\$8,200	\$8,286	\$8,214	\$8,000	\$7,900	\$7,833	\$7,667	\$7,625	\$7,500	\$7,300	\$7,200	\$7,000	\$6,750	\$6,700	
Row 9	Annual total cost of non-network solution (\$M)	\$4.2	\$4.1	\$5.8	\$5.8	\$4.0	\$4.0	\$4.7	\$4.6	\$6.1	\$6.0	\$5.8	\$7.2	\$9.1	\$8.8	\$8.7	\$65.0
Row 10	Total annual cost of meeting requirement (\$M)	\$7.9	\$7.8	\$9.5	\$9.5	\$11.4	\$11.4	\$12.1	\$12.0	\$13.5	\$13.4	\$13.1	\$14.5	\$16.4	\$16.0	\$16.0	\$138.2

As per case 1, the annual SSUP is set at \$7,634 per MVA for years 1-5 based on LRAC for years 1-10.

SSUP is reset in year 6 at \$7,275 per MVA based on the LRAC for years 6-15

In this example, at the end of year 5, the forecast costs of meeting the specified system strength requirements for the next 10 years are assessed. In this example, the costs of the network and non-network solutions for years 6 to 10 are unchanged from the initial assessment (shown in Case 1). Over years 11 to 15, the forecast unit costs of non-network solutions (shown in Row 8) are expected to fall.

It is estimated that the most cost-effective system strength resource that would be available to meet the remaining requirement (which will be met by network solutions) has a cost of \$7,250/MVA/year. Accordingly, the annual unit cost of the network solutions is adjusted down from \$7,400/MVA (Row 3) to \$7,250/MVA (Row 5). For the purpose of calculating the 10 year LRAC for years 6 to 15, the reduced forward-looking cost of the network solutions is adopted.²⁷ Accordingly, the values in Rows 3 and 4 for years 11 to 15 are shaded grey and excluded from the calculations, while the values in Rows 5 and 6 are used in the calculations instead.

The long run average cost of meeting the specified system strength requirements over years 6 to 15 is \$7,275 per MVA. It is calculated as the sum of the total annual costs over the period from years 6 to 15 (Row 10, \$138.2 million) divided by the sum of the system strength requirements over the same period (Row 1, 19,000). This cost is lower than the \$7,634/MVA/year calculated for the initial 10 year period, reflecting:

- the forecast reduction in the unit cost of non-network solutions over years 11 to 15; and
- the reduction in the forward-looking cost of network solutions for years 11 to 15.

As noted in relation to case 1, the above exposition has been simplified by assuming that the total system strength hosting capacity is the same as the system strength capacity provided at the node.

²⁷ Conversely, if the forward-looking annual costs were, say, \$8,000 per MVA, compared to ElectraNet's actual annual costs of \$7,400 per MVA, the lower costs would be adopted.

