



Basis of Preparation

AER Category Analysis

October 2017

Version FINAL

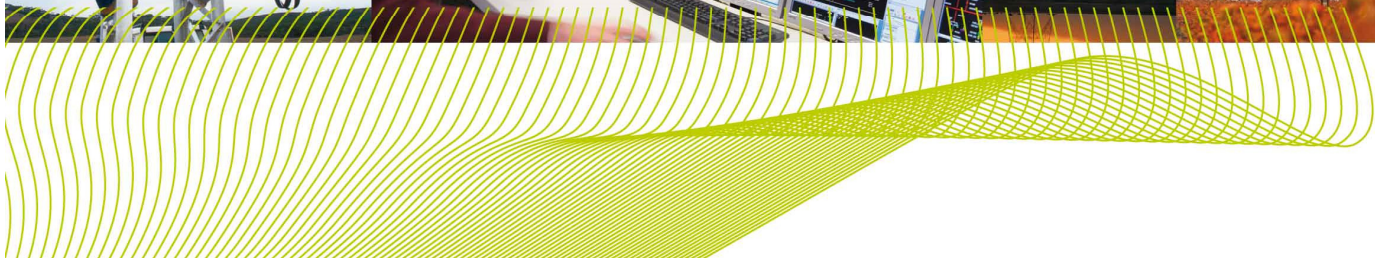

ElectraNet Corporate Headquarters

52-55 East Terrace, Adelaide, South Australia 5000 • PO Box, 7096, Hutt Street Post Office, Adelaide, South Australia 5000
Tel: (08) 8404 7966 • Fax: (08) 8404 7104 • Toll Free: 1800 243 853

Copyright and Disclaimer

Copyright in this material is owned by or licensed to ElectraNet. Permission to publish, modify, commercialise or alter this material must be sought directly from ElectraNet.

Reasonable endeavours have been used to ensure that the information contained in this report is accurate at the time of writing. However, ElectraNet gives no warranty and accepts no liability for any loss or damage incurred in reliance on this information.

Contents

1.	INTRODUCTION	7
2.	EXPENDITURE	8
2.1	EXPENDITURE SUMMARY	8
2.1.1	<i>Data requirement</i>	8
2.1.2	<i>Data source and methodology</i>	8
2.1.3	<i>Basis of estimation</i>	10
2.1.4	<i>Changes to accounting policies</i>	10
2.2	REPLACEMENT EXPENDITURE ('REPEX')	10
2.2.1	<i>Data requirement</i>	10
2.2.2	<i>Data source and methodology</i>	12
2.2.2.1	<i>Replacement Expenditure by Asset Category - Table 2.2.1</i>	13
2.2.2.2	<i>Volumes and Asset Failures by Asset Category– Table 2.2.1</i>	15
2.2.2.3	<i>Selected Asset Characteristics - Table 2.2.2</i>	16
2.2.3	<i>Basis of Estimation</i>	17
2.2.3.1	<i>Volumes and Asset Failures by Asset Category– Table 2.2.1</i>	18
2.2.4	<i>Changes to accounting policies</i>	20
2.3	AUGMENTATION PROJECT DATA ('AUGEX')	20
2.3.1	<i>Data requirement</i>	20
2.3.2	<i>Data source and methodology</i>	28
	<i>Augex asset data – Substations – Table 2.3.1</i>	29
2.3.3	<i>Basis of estimation</i>	35
2.3.4	<i>Changes to accounting policies</i>	35
2.5	CONNECTIONS.....	36
2.5.1	<i>Data requirement</i>	36
2.5.2	<i>Data source and methodology</i>	36
2.5.3	<i>Basis of estimation</i>	38
2.5.4	<i>Changes to accounting policies</i>	39
2.6	NON-NETWORK.....	39
2.6.1	<i>Data requirement</i>	39
2.6.2	<i>Data source and methodology</i>	43
2.6.2.1	<i>Non-network expenditure – Table 2.6.1</i>	43
2.6.2.2	<i>Annual Descriptor Metrics IT & Communications Expenditure – Table 2.6.2</i>	44
2.6.2.3	<i>Annual Descriptor Metrics Motor Vehicles – Table 2.6.3</i>	44
2.6.3	<i>Basis of estimation</i>	45
2.6.3.1	<i>Annual Descriptor Metrics IT & Communications Expenditure – Table 2.6.2</i>	45
2.6.4	<i>Changes to accounting policies</i>	45
2.7	VEGETATION MANAGEMENT	45
2.7.1	<i>Data requirement</i>	45
2.7.2	<i>Data source and methodology</i>	49
2.7.2.1	<i>Descriptor Metrics by Zone – Table 2.7.1</i>	49
2.7.2.2	<i>Expenditure Metrics by Zone – Table 2.7.2</i>	54
2.7.2.3	<i>Descriptor Metrics Across all Zones – Unplanned Vegetation Events (Table 2.7.3)</i>	54
2.7.3	<i>Basis of estimation</i>	55

2.7.4	<i>Changes to accounting policies</i>	55
2.8	MAINTENANCE	55
2.8.1	<i>Data requirement</i>	55
2.8.2	<i>Data source and methodology</i>	59
2.8.3	<i>Basis of estimation</i>	59
2.8.4	<i>Changes to accounting policies</i>	62
2.10	OVERHEADS	63
2.10.1	<i>Data requirement</i>	63
2.10.2	<i>Data source and methodology</i>	63
2.10.3	<i>Basis of estimation</i>	65
2.10.4	<i>Changes to accounting policies</i>	65
2.11	LABOUR	65
2.11.1	<i>Data requirement</i>	65
2.11.2	<i>Data source and methodology</i>	71
2.11.3	<i>Basis of estimation</i>	75
2.11.4	<i>Changes to accounting policies</i>	75
2.12	INPUT TABLES	75
2.12.1	<i>Data requirement</i>	75
2.12.2	<i>Data source and methodology</i>	75
2.12.3	<i>Basis of estimation</i>	78
2.12.4	<i>Changes to accounting policies</i>	78
5.	ASSET AND DEMAND INFORMATION	79
5.2	ASSET AGE PROFILE	79
5.2.1	<i>Data requirement</i>	79
5.2.2	<i>Data source and methodology</i>	82
5.2.3	<i>Basis of estimation</i>	87
5.2.4	<i>Changes to accounting policies</i>	88
5.3	MAXIMUM DEMAND NETWORK LEVEL	88
5.3.1	<i>Data requirement</i>	88
5.3.2	<i>Data source and methodology</i>	88
5.3.3	<i>Basis of estimation</i>	89
5.3.4	<i>Changes to accounting policies</i>	89
5.4	MAXIMUM DEMAND AND UTILISATION SPACIAL	89
5.4.1	<i>Data requirement</i>	89
5.4.2	<i>Data source and methodology</i>	93
5.4.3	<i>Basis of estimation</i>	98
5.4.4	<i>Changes to accounting policies</i>	99
	AER CATEGORY ANALYSIS RIN	100
	APPENDICES	100
	APPENDIX A ELECTRANET VEGETATION MANAGEMENT ZONES	101
A1	TOTAL NETWORK AREA WITH BORDERS FOR EACH VEGETATION MANAGEMENT ZONE	101
A1.1	<i>High Bushfire risk zones</i>	102

A1.2 *Bushfire risk zones* 103
A1.3 *Non-bushfire risk zones*..... 104

Tables

Table 2-1: Balancing Items – Capital Expenditure 9
Table 2-2: Balancing Items – Operating Expenditure 9
Table 2-3: Definitions Specific to Regulatory Template 2.2 - Repex 11
Table 2-4: Definitions specific to regulatory template 2.3 – Augex project data 26
Table 2-5: Definitions Specific to Regulatory Template 2.5 - Connections 36
Table 2-6: Annual Non-Network Expenditure - Table 2.6.1 39
Table 2-7: Annual Descriptor Metrics IT & Communications Expenditure – Table 2.6.2 41
Table 2-8: Annual Descriptor Metrics Motor Vehicles – Table 2.6.3 42
Table 2-9: Definitions Specific to Regulatory Template 2.7 - Maintenance 46
Table 2-10: Definitions Specific to Regulatory Template 2.8 - Maintenance 56
Table 2-11: Labour input classifications 65
Table 2-12: Definitions Specific to Regulatory Template 2.9 – Labour 68
Table 2-13: Labour Classification Mapping 71
Table 2-14: SAP Business Warehouse Queries – Labour Costs 72
Table 5-1: Definitions Specific to Regulatory Template 5.2 – Asset Age Profile 80
Table 5-2: Definitions Specific to Regulatory Template 4.3 - Maximum Demand and Utilisation - Spatial 91

Figures

Figure 2-1: Vegetation Clearance Corridor – Non Bushfire Risk Area 33kV to 66kV	51
Figure 2-2: Vegetation Clearance Corridor - Non Bushfire Risk Area 132kV to 275kV	52
Figure 2-3: Vegetation Clearance Corridor – Bushfire Risk Area 33kV to 66kV.....	52
Figure 2-4: Vegetation Clearance Corridor – Bushfire Risk Area 132kV to 275kV.....	53
Figure 2-5: Overhead View Vegetation Corridor Clearances.....	53
Figure 2-6: Examples of Support Structures.....	60

1. Introduction

On 7 March 2014, ElectraNet Pty Limited was served with a Regulatory Information Notice pursuant to Division 4 of Part 3 of the National Electricity (South Australia) Law (the RIN).

A requirement of the Category Analysis RIN set out in the Instructions and Definitions accompanying the RIN, is that ElectraNet in addition to providing to the AER a completed data template, must provide a 'Basis of Preparation' which explains for each variable inputted to the data template the basis upon which the input has been prepared.

In accordance with the requirements of the RIN, the following sections of this report provides ElectraNet's basis of preparation for all variables inputted to the data template accompanying this report. Consistent with the Instructions and definitions this basis of preparation addresses the following:

- How the information provided is consistent with the requirements of the notice;
- Explains the source from which ElectraNet obtained the information provided;
- Explains the methodology ElectraNet applied to provide the required information, including any assumptions ElectraNet made;
- Where ElectraNet could not provide an input for a variable using actual information and an estimate was required:
 - Why an estimate was required, including why it was not possible for ElectraNet to use actual information; and
 - The basis for the estimate, including the approach used, assumptions made and reasons why the estimate is ElectraNet's best estimate, given the information sought in the notice.
- In the case of financial information, an explanation if applicable, of the nature and impact of any accounting changes adopted by ElectraNet which have materially changed during any of the regulatory years covered by the notice.

In accordance with the requirements of the RIN, ElectraNet is submitting this final Basis of Preparation and accompanying audited and verified version of the data template and supporting audit report.

2. Expenditure

2.1 Expenditure Summary

2.1.1 Data requirement

ElectraNet has summarised the data inputs for Capital Expenditure (capex) and Operating Expenditure (opex) in *Tables 2.1.1 and 2.1.2*.

Table 2-1 - Capex is reported “as incurred,” that is, reporting when an expense related to a project has actually been incurred, and is balanced to capital expenditure as provided to the AER in the Annual Regulatory Financial Report. The balancing items comprise overhead which is excluded from the data template 2.12 and expenditure on categories which were not requested to be included in the RIN templates.

Table 2-2 - Opex is reported consistently with information contained in the data templates 2.6 to 2.12 and is balanced to opex reported to the AER in the Annual Regulatory Financial Report.

Each Annual Regulatory Financial Report contains a reconciliation to ElectraNet’s audited statutory accounts.

2.1.2 Data source and methodology

Capital Expenditure

Cost excluding overhead is sourced from data template 2.12, for augmentation, connections, replacement and non-network expenditure.

Overhead charged to capex is sourced from overhead allocations prepared and described in sections 2.10 and 2.12 of this Basis of Preparation.

Capex balancing items detailed in [Table 2-1](#) comprise:

- Capital expenditure spend on projects not requested in the RIN analysis; and
- Difference on overhead component of capex, due to the estimation basis used in the compilation of RIN information.

Table 2-1: Balancing Items – Capital Expenditure

	2016/17 \$'0
Capex total before balancing items	150,294,995
Overhead in above capex	0
Labour provisions movement excluded from Annual Financial Regulatory Report	0
Other	(1,061)
Capex per Annual Financial Regulatory Report	150,293,936

Opex

Cost, excluding overhead, is sourced from templates 2.6, 2.7 and 2.8 for non-network, vegetation and maintenance. Network and corporate overheads are sourced from template 2.10.

Non-network cost is a balancing item adjustment as all non-network cost is included in overheads. Other balancing items are sourced from the Annual Financial Regulatory Report and from ElectraNet's analysis in "F17 S&H Data". These comprise:

- Overhead charged to regulated capex;
- Overhead charged to non-regulated capex and opex;
- Network support;

Opex balancing items are detailed in [Table 2-2](#).

Table 2-2: Balancing Items – Operating Expenditure

	2016/17 \$'0
Opex total before balancing items	104,062,485
Non-network included in overheads	(8,990,972)
Labour in vegetation management	(147,927)
Vegetation management in Maintenance	(2,038,898)
Total overhead items	(10,635,009)
Network support	7,486,570
Other	(96,616)
Opex per Annual Financial Regulatory Report	89,639,633

2.1.3 Basis of estimation

This summarisation template results from estimates made in the completion of data templates 2.2 to 2.12 and reconciles to final actual capex and opex as reported to the AER in Annual Regulatory Financial Reports.

ElectraNet has presented the RIN information in accordance with the cost centre mapping as approved in the 2013-2018 revenue reset opex allowance.

2.1.4 Changes to accounting policies

N/A – Information reported in the data template 2.12 is not impacted by any accounting changes during the reporting period as figures reported reflect actual expenditure.

2.2 Replacement Expenditure ('Repex')

2.2.1 Data requirement

Consistent with the AER's Definitions and Instructions, ElectraNet has provided information to the AER on replacement capital expenditure in *Table 2.2.1* of the data template on the following basis:

- a) Where ElectraNet provides asset sub-categories corresponding to the prescribed asset categories in *Table 2.2.1*, ElectraNet must ensure that the expenditure and asset replacement / asset failure volumes of these sub-categories reconcile to the higher level asset category. ElectraNet is required to insert additional rows and provide a clear indication of the asset category applicable to each sub-category. ElectraNet must provide corresponding age profile data in the template 5.2 as per its instructions.
- b) In instances where ElectraNet is reporting expenditure associated with asset refurbishments/ life extensions capex it must insert additional rows at the bottom of the table for the relevant asset group to account for this. ElectraNet must provide the required data, applying the corresponding asset category name followed by the word "REFURBISHED". ElectraNet must provide corresponding age profile data in the template 5.2 as per its respective instructions.
- c) In instances where ElectraNet considers that both the prescribed asset group categories and the sub-categorisation provisions set out in (b) do not account for an asset on ElectraNet's transmission system, ElectraNet must insert additional rows below the relevant asset group to account for this. ElectraNet must provide the required data, applying a high level descriptor of the asset as the category name. The section item titled "OTHER BY" illustrates this requirement. ElectraNet must provide corresponding age profile data in template 5.2 as per its respective instructions. ElectraNet must ensure that the sum of the individual asset categories, including any additional sub-category, additional other asset category or asset refurbishment/ life extension asset category expenditure reconciles to the total expenditure of the asset group.
- d) ElectraNet must ensure that the replacement volumes by asset group level is equal to the applicable replacement volume data provided in *Table 2.2.2*.

- e) ElectraNet must ensure that the sum of the asset group replacement expenditures is equal to the total replacement expenditure contained in *Table 2.2.1*.
- f) If ElectraNet has provided estimated expenditure data on the basis of historical data that has included works across asset groups ElectraNet must provide the asset age profile data in template 5.2 against the most elementary asset category. For example, where ElectraNet replaces substation switchbay in conjunction with a substation power transformer it must report the asset age profile data against the relevant substation switchbay asset category. ElectraNet must provide documentation of instances where backcast unit costs generated have involved allocations of historical records that include expenditure across asset groups.

Consistent with the AER’s Definitions and Instructions, ElectraNet has provided information to the AER on replacement capital expenditure in *Table 2.2.2* of the data template on the following basis:

- a) ElectraNet must provide total volume of assets currently in commission and replacement volumes of certain asset groups by specified aggregated metrics. In instances where this information is estimated ElectraNet must explain how it has determined these volumes, detailing the process and assumptions used to allocate asset volumes to the aggregated metrics.

Additionally, definitions specific to data template 2-3 – Repex are detailed in [Table 2-3](#).

Table 2-3: Definitions Specific to Regulatory Template 2.2 - Repex

Term	Definition
Asset Failures	<p>The failure of an asset to perform its intended function safely and in compliance with jurisdictional regulations, not as a result of external impacts such as:</p> <ul style="list-style-type: none"> • extreme or atypical weather events; or • third party interference, such as traffic accidents and vandalism; or • wildlife interference, but only where the wildlife interference directly, clearly and unambiguously influenced asset performance; or • vegetation interference, but only where the vegetation interference directly, clearly and unambiguously influenced asset performance. <p>Excludes planned interruptions.</p>
MVA _r	Reactive capacity
Replacement Capital expenditure — ‘Repex’	The non-demand driven capex to replace an asset with its modern equivalent where the asset has reached the end of its economic life. Capex has a primary driver of replacement expenditure if the factor determining the expenditure is the

Term	Definition
	existing asset's inability to efficiently maintain its service performance requirement.

2.2.2 Data source and methodology

The information provided by ElectraNet is sourced from ElectraNet's general ledger, projects systems and from internal capital project estimates.

Physical Asset Count

ElectraNet used a number of internal sources to estimate asset volumes for each asset category identified in *Table 2.2.1* of the data response template. Where possible, ElectraNet has used the asset information handover report to establish asset volumes as the preferred primary source of information.

However, other data sources were used to identify asset volumes where the asset information was incomplete or inconsistent in the asset information handover report. Data sources used are identified below in order of preference as a source of information for ElectraNet to determine asset volumes:

- Asset information project handover report ("the databook");
- Capitalisation worksheet;
- Project estimate (Level 3, 2, 1, A);
- Post Implementation Review;
- Project brief; and
- Project action advice, scope and estimate (SAE).

The number of data sources used reflects the fact that project management methodologies have changed over time and that the quality of project documentation often varied significantly from project to project.

Where asset information appeared to be inconsistent, ElectraNet interrogated SAP, ElectraNet's internal asset management system, to reconcile assets created in the system on the same date against the new assets identified for the relevant project. The line schedules database and new and historical system switching diagrams also provided secondary sources.

This approach was only adopted where appropriately detailed asset handover information was not available.

Note that asset failures have been input as zero in the data response template. As per the Definitions and Instructions, asset failures are defined as an asset failure in service. ElectraNet note that the primary purpose of replacement capital expenditure is to replace an asset prior to failure. In the case that an asset fails in service, generally ElectraNet will replace the asset as part of an operating expenditure project due to the often long lead times to initiate a capital expenditure project.

2.2.2.1 Replacement Expenditure by Asset Category - *Table 2.2.1*

Project Costs

ElectraNet has extracted project cost information for all projects for which spending was completed during the period. This information has been extracted from ElectraNet's project reporting system. ElectraNet has determined the completion of projects by reviewing any planned future spend and by verifying the project status with the Senior Network Project Sponsor. Internal ElectraNet costs charged to projects have been amended to exclude overheads.

Treatment of overheads

The RIN definitions and instructions require that overhead costs be excluded from reported project costs.

From 1 July 2010 onwards ElectraNet has incorporated overheads into the team cost centre activity rates which are applied to booked hours used to charge costs to projects and other cost collectors. The activity rates comprise four cost types. These are:

- Direct team labour cost – primary cost;
- Other direct team expense- primary cost;
- Supervisory overhead cost – secondary cost; and
- Administration overhead cost – secondary cost.

Primary costs are the first occurrence of charges and generally originate outside the ElectraNet business.

Secondary costs are costs already incurred which are transferred within the business.

The exclusion of overhead from activity rates requires the removal of secondary costs from overhead rates.

ElectraNet has two categories of activity – direct and indirect as defined below:

- Direct activities are those which are incurred on operating and maintaining the network and in the construction of assets; and
- Indirect activities support the direct activities – e.g. general business activity, training, compiling policies and procedures.

ElectraNet has two categories of teams. These are direct and support teams. Support teams incur supervisory overhead only. After any direct activity is charged by these teams, the main portion of the remaining team cost is then allocated to the direct teams as administration overhead. This overhead is allocated based on the hours worked by direct teams each month.

Direct team activity rates incorporate all four cost types.

ElectraNet calculates budget activity rates for all teams. From 1 July 2015 onwards all team rates have been actualised each month.

Up to 2015/16 contract labour was incorporated into team activity rates as an oncost. In 2016/17 contract labour was excluded from team rates and for those teams which employed contract labour, an average team contract labour rate was calculated. Contract labour hours were charged to activities at team contract labour rates.

Exclusion of overhead

ElectraNet extracted detailed costs from its SAP system for the reporting year. This information comprises cost centre, cost element, costs, activity hours charged and the partner cost objects, i.e. the receiver or sender of the charge e.g. a capex project.

To calculate team direct cost activity rates, ElectraNet applied its rate calculation methodology described previously to determine team direct cost rates for both budgeted and actual costs for the reporting period.

To apply team direct cost activity rates to projects, ElectraNet analysed projects by sending cost centre showing cost and hours charged to each project each year. Team direct rates are applied for each cost centre's annual time booking to each project. Actual team direct rates are applied for direct teams for the reporting period. These rates are multiplied by the related hours charged to derive project costs net of overhead. This information was summarised by project and the difference between full rates and team direct rates was calculated, being the overhead to exclude from each project for the purposes of RIN reporting.

ElectraNet then applied an overhead reduction to project costs from the summarised project cost data, where the life of project overhead cost was calculated for each project and applied to give a project cost, net of overhead.

Replacement expenditure

ElectraNet extracted information from its fixed asset system for completed replacement projects. This information comprised network assets analysed by project and by asset class for assets at bay level (substation primary plant) and built section level (transmission lines). These primary plant and transmission lines assets are recorded in the fixed asset system at an aggregate of the plant and component items which are required to be reported in the replacement expenditure *Table 2.2.1*.

This fixed asset system information was used to apportion project cost to the major categories in *Table 2.2.1*, i.e. transmission lines and cables, primary plant, site establishment etc.

Individual equipment and material item costs provided by Project Estimating were then used as the basis to apportion the category cost to the required detailed analysis in *Table 2.2.1*.

2.2.2.2 Volumes and Asset Failures by Asset Category– *Table 2.2.1*

Transmission Towers

Transmission towers are included as an asset replacement if a new tower is constructed or there are known major tower works such as new footings, lifting cross arms etc. Note that the Line Schedules database only identifies new towers when they are constructed.

Transmission Tower Support Structures

For the purposes of this analysis, transmission tower support structures are defined as a cross arm and an insulator assembly. Unless otherwise specifically identified, for each suspension tower it is assumed it has one support structure per phase and for each tension tower it is assumed to have three support structures per phase. The determination of if the tower is suspension or tension comes from the Line Schedule database for that structure. Tension towers are described as tension, brace or angle.

Conductors & Transmission Cables

A count of one is assumed for any continuous circuit length of conductor. Ratings have been determined based by ElectraNet circuit, the maximum (winter) rating for continuous operating plant ratings.

Switchgear

All switchgear assets assume a three phase set.

Insulation

Insulation is assumed to be on the basis of the external insulation (bushing), not the internal breaking mechanism. Earth switches have not been counted additionally to the isolator.

Transformers

Ratings assumed reflect the highest nameplate rating (ODAF).

SVC

SE SVC SS systems replacement for the purposes of this analysis is assumed to be full SVC replacement.

SCADA, Network Control and Protection Systems

As ElectraNet's capitalisation methodology refers to the 3rd level functional location (i.e. the Bay level), it is difficult to determine associated project secondary systems (due to their large number and small value). Due to this, assets have been split into categories on the basis of ElectraNet's internal project estimating tool at a high level. It has been assumed that category is only allocated that function for major capital works. Within these 5 (including other) remaining categories allocation of residual cost is performed, these are effectively flags that denote work within that area.

Secondary systems is only categorised for significant works such as protection relays, metering etc.

Telecommunications is only categorised for significant works such as a new SCADA, network control (includes OCS).

Site establishment is only categorised if the project has major site establishment works (i.e. new substation, roads, control building, diesel generators, footings and drainage).

OPGW is counted if there was any OPGW work in the project.

Other

The other asset grouping is used to capture projects which have any capital works which cannot be categorised into any of the defined asset groups.

Operational Refurbishment

Refurbishment of an asset has been defined as extension of life of the asset.

Past practice for ElectraNet for works within a substation is that it would generally not refurbish anything smaller in dollar value than a transformer due to the small cost of CB's, disconnectors etc. compared with labour, lack of expertise and spare parts, and the risk of introducing new failure modes. Refurbishments for assets less than a transformer will only be counted if explicitly mentioned in the project documentation.

For transmission lines, the act of tower strengthening is taken to be adding more function or capacity; hence it has not been classed as refurbishment.

2.2.2.3 Selected Asset Characteristics - *Table 2.2.2*

Conductor Length

Conductor is given as circuit length kilometres. Any types of conductor with current volumes of less than one circuit km have been excluded. A conductor is three phases of regulated transmission line. This is irrespective of how many conductors per phase and excludes earth wires. Conductor types with special core coatings or non-specular coatings are combined to the parent or predominant conductor type. Methodology and assumptions to determine these lengths is detailed in the basis of preparation for section 2.7. De-energised lines are included in the provided figures. This is as these lines can be returned to service quickly with minor works and these sections are still maintained.

Underground cables are excluded.

SVCS

The SVC unit count is defined by the associated step up transformer. Sizes were determined from the relevant system switching diagrams (SSD's). The size is the maximum Mvar magnitude that the SVC is capable when categorising the Mvar size of an SVC.

Capacitors

Asset information is derived from the Network Statistics Report (Capcans tab) that extracts data from SAP. This contains information on equipment size, dimension and regulated status of the capacitors. As some these pieces of plant can be classified down to the single phase unit the count must be made consistent with the assumption that is all assets are by per 3 phase set. These can be identified by the phase code letters. Size is contained within the equipment size / dimension field.

Oil Filled Reactors

Asset information is derived from the Network Statistics Report that extracts data from SAP. This contains information on equipment size, dimension, reactor type and regulated status of the reactors. The extracted data has been filtered to include oil filled reactors only. The reactor size is contained within the Equipment description and the equipment size / dimension field. For the purposes of this analysis spares have been excluded.

Asset Replacements

Volumes identified in the asset replacements categories are as identified in *Table 2.2.1*, for that category and year. For conductor length the source is either the Line Schedule database which has the new structures at a new date and then can be used to calculate the sum of the spans (including landing spans), or the measure tool application within Google Earth. Additional conductor lengths are rounded to the nearest 100m.

Asset Replacement Year is done on a project close basis as requested by the AER hence these may not match assets reported in other sections of the RIN that are prepared on the basis of the energisation / commissioning date.

2.2.3 Basis of Estimation

For the individual reporting categories within the Repex data template 2.2, ElectraNet have used several data sources including:

- Cost estimates produced for projects;
- ElectraNet's corporate cost library which resides in the corporate cost estimating system Success Enterprise;
- Extrapolation from cost library items where data for the asset group requested is not available; and
- Level 3 Estimates which contain data from vendor bids for project works.
- Capitalised asset values extracted from ElectraNet's SAP fixed asset system

Where no as-incurred information was available at the project close date, the relevant unit price has been extracted from ElectraNet's corporate estimating cost library. This cost has then been adjusted to reflect real costs for the relevant period using indices, in this instance CPI.

Also where unit costs are to be provided, these are aggregated across the numerous projects identified. Rather than use an average which could skew the data presented, we have elected to show unit cost rates that are extracted directly from the cost library and to back cast these to the applicable period using CPI.

Because ElectraNet's corporate estimating system holds cost library data in a structured manner, it can readily be extracted down to materials and labour resource level.

Where actual information was not available, ElectraNet has presented unit rates from the cost library. The library itself is informed by vendor data and from period plant contracts for major items of electrical equipment.

These estimated costs have been used as a basis to allocate the costs for each high level RIN Category section to the individual components identified in accordance with the RIN template.

2.2.3.1 Volumes and Asset Failures by Asset Category– *Table 2.2.1*

Transmission Towers

In estimating the number of transmission towers at the end of each year of the reporting period, ElectraNet has assumed the following:

- A tower relates to the structures on transmission lines, not substation structures;
- Poles are considered towers, substation towers such as gantries, earth wire poles etc. were excluded from the count;
- Pi structures (2 poles) are considered one tower;
- 3 single phase vertical angle poles are considered as one tower; and
- The count of transmission towers only relates to regulated structures.

For the purposes of this analysis, multiple circuits include both double and triple circuit towers and voltage refers to the highest voltage if there are multiple circuits of differing voltages.

Conductors

Conductor has been defined as the circuit kms of conductor by built section. A conductor is three phases of regulated transmission line. This is irrespective of how many conductors per phase and excludes earth wires.

Line rating (MVA) is the highest normal thermal rating (not constraining plant). Underground cables were excluded from the analysis.

Cables

A cable has been defined by the circuit kms of cable. A cable is three phases of regulated underground cable. This is irrespective of how many conductors per phase.

High voltage underground cables which are part of the transmission line feeder system are included; and high voltage cables within substations which are used only internally to within the substation are excluded from the calculation. 66kV cables have been included in this analysis.

Air Insulated Circuit Breakers

Load switches have been excluded from the analysis.

Air Insulated Isolators / Earth Switch

Earth switches are not counted additionally to the isolator (i.e. insulator with earth switch equals 1, earth switch by itself equals 0 and insulator with double position earth switch equals 1).

VT

Either insulation type is included. Combined CT & VT's are classed as CT's. VT's at a voltage less than 10kV are excluded.

CT

Either insulation type is included. Combined CT & VT's are classed as CT's. Internal cap balance VT's are excluded. CT's at a voltage less than 10kV are excluded. Leakage or neutral Overcurrent CT's are excluded.

GIS Module

The GIS module is assumed to be any circuit switching element that is gas insulated, that is, GIS circuit breakers and isolators consistent with the definitions in the RIN instructions and definitions. It is not inclusive of standalone Earth switches.

Substation Power Transformers

The rating reported is the highest transformer nameplate with forced cooling if available (ODAF). The analysis includes SVC transformers, but AC supply transformers have been excluded.

SVCS

An SVC unit is defined by its step up transformer.

Oil Filled Reactors

The analysis includes regulated assets only. Spares have been excluded.

Insulation type is taken to be for the external insulation (bushing) not the internal breaking mechanism (i.e. how the phases are insulated from each other and ground).

All plant and equipment units added are per 3 phase set.

Air cooled reactors that are used in applications that would typically require oil filled reactors, such as network voltage control are included within this category. Other Air cooled reactors that are used for the applications that would typically require air cooled reactors such as fault level control, inrush or harmonic filtering purposes are excluded.

2.2.4 Changes to accounting policies

There are no changes to accounting policies which impact ElectraNet's project values.

2.3 Augmentation Project Data ('Augex')

2.3.1 Data requirement

Consistent with the AER's Definitions and Instructions, ElectraNet has provided information to the AER on augmentation project data in 2.3 of the data template on the following basis:

General instructions for regulatory template 2.3:

- a) ElectraNet must include only projects and expenditure related to augmentation of the network.
- b) Unless otherwise indicated, 'Rating' or 'MVA added' refers to equipment's normal cyclic rating (for substations) or thermal rating (for lines and cables). As specified in the respective definitions of normal cyclic rating (for substations) and thermal rating (for lines and cables), ElectraNet must provide its definition(s) of 'normal conditions' in the basis of preparation.
- c) ElectraNet must not include information for gifted assets.
- d) ElectraNet must enter related party and non-related party contracts expenditures in the 'All related party contracts' and 'All non-related party contracts' columns, respectively.
 - i. Expenditure figures inputted into the 'All related party contracts' and 'All non-related party contracts' columns do not contribute to the column that calculates the total direct expenditure on an augex project ('Total direct expenditure').
 - ii. ElectraNet must record all contract expenditure for augex projects under the 'All related party contracts' and 'All non-related party contracts' columns. ElectraNet must then allocate such contract expenditure to the appropriate 'Plant and equipment expenditure and volume' and 'Other expenditure columns. For example, if a non-related party contract involves expenditure on civil works, ElectraNet must record that expenditure under the 'All non-related party contracts' and 'Other expenditure – Civil works' columns.
- e) ElectraNet must not include augmentation information relating to connections in this worksheet. Augmentations in relation to connections are to be inputted in the connections regulatory template (worksheet 2.5).

Table 2.3.1 (on regulatory template 2.3) instructions state:

- a) *For projects with a total cumulative expenditure over the life of the project of greater than or equal to \$5 million (nominal):*
 - i. *insert a row for each augmentation project on a substation owned and operated by ElectraNet where project close occurred at any time in the years specified; and*
 - ii. *input the required details.*
- b) *For projects with a total cumulative expenditure over the life of the project less than \$5 million (nominal) (non-material projects):*
 - i. *input the total expenditure for all non-material augmentation projects on a substation owned and operated by ElectraNet where project close occurred in the years specified in the penultimate line in the table, as indicated.*
- c) *Record all expenditure data on a project close basis in real dollars (\$2012–13). ElectraNet must not include data for augmentation works where project close occurs after the years specified but incurs expenditure prior to this date.*
 - i. *ElectraNet must provide any calculations used to convert real to nominal dollars or nominal to real dollars for this purpose.*
- d) *For the avoidance of doubt, this includes augmentation works on any substation in ElectraNet's network, including those which are notionally operating at distribution voltages. In such cases, choose 'Other - specify' in the 'Substation type' category and describe the type of substation in the basis of preparation.*
- e) *Each row must represent data for an augmentation project for an individual substation.*
 - i. *If an augmentation project applies to two substations, for example, ElectraNet must enter data for the two substations in two rows.*
- f) *Where a substation augmentation project in this table is related to other projects (including those in other tables in regulatory template 2.3), describe this relationship in the basis of preparation.*
- g) *Where ElectraNet chooses 'Other - specify' in a drop down list, it must provide details in the basis of preparation.*
- h) *For 'Substation ID' and 'Project ID', input ElectraNet's identifier for the substation and project, respectively. This may be the substation/project name, location and/or code.*
- i) *For 'Project trigger', choose the primary trigger for the project from the drop down list. Describe secondary triggers in the basis of preparation. Where there is no primary trigger (among multiple triggers), choose 'Other – specify' and describe the triggers in the basis of preparation.*

- j) *For substation voltages, enter voltages in the format xx/xx, reflecting the primary and secondary voltages. For example, a transformer may have its voltage recorded as 500/275, where 500kV is the primary voltage and 275kV is the secondary voltage.*
- k) *Where a tertiary voltage is applicable, enter voltages in the format xx/xx/xx. For example, a transformer may have its voltage recorded as 220/110/33, where 220kV, 110kV and 33kV are the primary, secondary and tertiary voltages, respectively.*
- l) *For substation ratings, 'Pre' refers to the relevant characteristic prior to the augmentation work; 'Post' refers to the relevant characteristic after the augmentation work. Where a rating metric does not undergo any change, or where the project relates to the establishment of a new substation, input the metric only in the 'Post' column.*
- m) *Under 'Total expenditure' for transformers, switchgear, reactive plant, and other plant items, include only the procurement costs of the equipment. This must not include installation costs.*
- n) *Expenditure inputted under the 'Land and easements' columns is mutually exclusive from expenditure that appears in the columns that sum to the 'Total direct expenditure' column. In other words, the 'Total direct expenditure' for a particular project must not include expenditure inputted into the 'Land and easements' columns.*
- o) *If ElectraNet records land and easement projects and/or expenditures as separate line items for regulatory purposes, select 'Other – specify' from the 'Project type' drop down list and note 'Land/easement expenditure' in the basis of preparation.*
 - i. *ElectraNet must input expenditure directly attributable to the land purchase or easement compensation payments in the 'Land purchases' and 'Easements' columns, respectively. These costs include legal, stamp duties and cost of purchase or easement compensation payments.*
 - ii. *ElectraNet must input other expenditure attributable to land purchases and easements in the 'Other expenditure – Other direct' column.*
- p) *Insert additional rows as required.*
- q) *Definitions: Other plant item*
- r) *(All equipment involved in utilising or transmitting electrical energy that are not transformers, switchgear, or reactive plant.*

Table 2.3.2 (on regulatory template 2.3) instructions state:

- a) *For projects with a total cumulative expenditure over the life of the project of greater than or equal to \$5 million (nominal):*

- i. insert a row for each augmentation project on a line or cable owned and operated by ElectraNet where project close occurred at any time during the years specified; and*
 - ii. input the required details.*
- b) For projects with a total cumulative expenditure over the life of the project less than \$5 million (nominal) (non-material projects):*
 - i. input the total expenditure for all non-material augmentation projects on lines or cables owned and operated by ElectraNet where project close occurred in the years specified in the penultimate line in the table, as indicated.*
- c) Record all expenditure data on a project close basis in real dollars (\$2012–13). Hence, ElectraNet must not include data for augmentation works where project close occurs after the years specified but incurs expenditure prior to this date.*
 - i. ElectraNet must provide any calculations used to convert real to nominal dollars or nominal to real dollars for this purpose.*
- d) For the avoidance of doubt, this includes augmentation works on any line or cable in ElectraNet's network, including those which are notionally operating at distribution voltages. In such cases, describe the type of line or cable in the basis of preparation.*
- e) Each row should represent data for all circuits of a given voltage subject to augmentation works under the Project ID.*
 - i. If an augmentation project applies to two circuits of the same voltage, for example, ElectraNet must enter data for the two circuits in one row.*
 - ii. If an augmentation project applies to two circuits of different voltages, for example, ElectraNet must enter data for the two circuits in two rows*
- f) Where a lines or cables augmentation project in this table is related to other projects (including those in other tables in regulatory template 2.3), describe this relationship in the basis of preparation.*
- g) Where ElectraNet chooses 'Other - specify' in a drop down list, provide details in the basis of preparation.*
- h) For 'Line ID', input ElectraNet's identifier for the circuit(s) subject to augmentation works under the Project ID. This may be the circuit name(s), location and/or code.*
- i) For 'Project ID', input ElectraNet's identifier for the project. This may be the project name, location and/or code.*
- j) For 'Project trigger', choose the primary trigger for the project from the drop down list. Describe secondary triggers in the basis of preparation. Where there is no primary trigger (among multiple triggers), choose 'Other – specify' and describe the triggers in the basis of preparation.*

- k) *For line and cable ratings, 'Pre' refers to the relevant characteristic prior to the augmentation work; 'Post' refers to the relevant characteristic after the augmentation work. Where a line or cable rating does not undergo any change, or where the project relates to the establishment of a new line or cable, input the metric only in the 'Post' column.*
- l) *For length metrics, 'km added' refers to the gross addition of the relevant length measure resulting from the augmentation work.*
 - i. *This must not be net of line or cable removal. If the augmentation project includes line or cable removal, describe the amount in the basis of preparation.*
- m) *Under 'Total expenditure' for towers/poles, include the procurement costs of the equipment and civil works. This must not include installation costs.*
- n) *Under 'Total expenditure' for lines, cables and 'other plant item', respectively, include only the procurement costs of the equipment. This must not include installation costs.*
- o) *Under 'Total expenditure' for civil works, do not include civil works expenditure related to towers/poles. As a guide, expenditure ElectraNet may input under 'Other expenditure – Civil works' includes (but is not limited to) construction of access tracks, construction pads and vegetation clearance.*
- p) *Expenditure inputted under the 'Land and easements' columns is mutually exclusive from expenditure that appear in the columns that sum to the 'Total direct expenditure' column. In other words, the 'Total direct expenditure' for a particular project must not include expenditure inputted into the 'Land and easements' columns.*
- q) *If ElectraNet records land and easement projects and/or expenditures as separate line items for regulatory purposes, select 'Other – specify' in the 'Project type' drop down list and note 'Land/easement expenditure' in the basis of preparation.*
 - i. *ElectraNet must input expenditure directly attributable to the land purchase or easement compensation payments in the 'Land purchases' and 'Easements' columns, respectively. These costs include legal, stamp duties and cost of purchase or easement compensation payments.*
- r) *ElectraNet must input other expenditure attributable to land purchases and easements in the 'Other expenditure – Other direct' column.*
- s) *Insert additional rows as required.*
- t) *Definitions: Other plant item*
 - i. *All equipment involved in utilising or transmitting electrical energy that are not towers/poles (including pole top or tower structures), lines or cables.*
 - ii. *This may include cable termination, cable transition and line diversion.*

Table 2.3.3 instructions state:

- a) *ElectraNet must input the total augmentation expenditure for each asset group split by the groupings specified by the table.*
 - i. *Record all expenditure data on an 'as incurred' basis in nominal dollars.*
- b) *ElectraNet must explain how the sum of the asset group augmentation expenditures reconciles to the augmentation expenditure in tables 2.3.1 and 2.3.2.*

The following **Table 2-4** details the different definitions that are specific to the data template 2.3 – Augex Project Data.

Table 2-4: Definitions specific to regulatory template 2.3 – Augex project data

Term	Definition
Augmentation	Has the meaning prescribed in the National Electricity Rules, and also includes work relating to improving the quality of the network, for example, to meet regulatory obligations.
Auxiliary transformer	A transformer installed normally within a substation to provide power supply to substation auxiliaries, such as controls, motors, and communication facilities.
Cable	These assets have the primary function of transmitting power, below ground, between segments of the network. This includes the material primarily used to transmit the power and any insulation or housing this material requires.
Circuit line length	The aggregate length in kilometres of transmission lines and cables, measured as the aggregate length of all circuits irrespective of how many circuits exist in a single span. Length does not take into account vertical components such as sag.
Civil works	The construction and/or installation of the infrastructure which will house or provide supporting foundations for electrical cables and equipment. It includes buildings, earthworks, foundations, access roads, as well as support structures not included in any other category.
Easement	All rights to enjoyment over property not registered to ElectraNet and includes, without limitation, rights to access and maintain land, build and maintain assets on land and way-leaves
Line	These assets have the primary function of transmitting power, above ground, within the transmission network. It excludes any assets that are included in any other asset category.
N-1 emergency (for lines cables)	The maximum peak load for a given load cycle that a line can supply for up to 15 minutes under a single contingency emergency condition.
N-1 emergency (for substations)	The maximum peak load for a given load cycle that a substation can supply for up to two hours under a single contingency emergency condition.
Network	Has the meaning prescribed in the National Electricity Rules

Term	Definition
Normal cyclic rating	The maximum peak loading based on a given daily load cycle that an asset or element of the network can supply each day of its life under normal conditions resulting in a normal rate of wear. ElectraNet must provide its definition(s) of 'normal conditions'
Normal cyclic rating (for substations)	The maximum peak loading based on a given daily load cycle that a substation can supply each day of its life under normal conditions resulting in a normal rate of wear. ElectraNet must provide its definition(s) of 'normal conditions'.
OLTC	On load tap changer
Project close	When the project account(s) are closed off at the completion of the project.
Reactive plant	Has the meaning prescribed in the National Electricity Rules
Reactor	Has the meaning prescribed in the National Electricity Rules
Route line length	The aggregate length in kilometres of transmission lines (and cables), measured as the length of each span between towers/poles, and where the length of each span is considered only once irrespective of how many circuits it contains. Length does not take into account vertical components such as sag.
Static VAR compensator	Has the meaning prescribed in the National Electricity Rules
Substation	Has the meaning prescribed in the National Electricity Rules As a guide, assets included within a substation include all equipment, buildings, structures, civil works and other assets that are located permanently within the substation boundary fence; but excluding the landing spans of incoming or outgoing overhead lines, and excluding incoming or outgoing cables and associated cable terminations (cables includes all power, communications and control cables).
Switchgear	These are assets used to control, protect and isolate segments of the network This includes disconnect switches, fuses, circuit breakers, reclosers, sectionalises, etc. It excludes any pole mounted assets that are included in any other asset category.
Switching station	A station that connects to multiple circuits but does not contain a transformer.

2.3.2 Data source and methodology

Unless otherwise indicated, 'Rating' or 'MVA added' refers to equipment's normal cyclic rating (for substations) or thermal rating (for lines and cables). As specified in the respective definitions of normal cyclic rating (for substations) and thermal rating (for lines and cables), ElectraNet must provide its definition(s) of 'normal conditions' in the basis of preparation.

Normal cyclic rating (for substations)

The normal cyclic rating is determined by ageing of the insulation, and for planning purposes corresponds to a nominal transformer life of 30 years when associated with average ambient temperature values. This strategy of calculating the normal cyclic rating, together with the actual loading patterns on a transformer, enables the transformers to reach a technical life of typically at least 45 years.

Loading to this normal cyclic rating is assumed to be acceptable during planned outages of plant, for example, during maintenance activities. The normal cyclic ratings is also used to determine the maximum allowable loading on an ETC Category 1 substation (i.e. where there is usually only one transformer installed, or even with multiple units, the substation capacity is limited by its "N" capacity).

As per AS 2374.7-1997, for medium power transformers (up to 100MVA), this value is checked against two aspects of performance on a very hot day (i.e. not using average temperatures), when the hottest point on the transformer windings (hot spot) must not exceed 140°C and the oil temperature must not exceed 105°C. In no case is the cyclic rating permitted to exceed 1.5 times the nameplate rating. The normal cyclic rating is the lowest of these four values.

For large power transformers (above 100MVA), this value is checked against two aspects of performance on a very hot day (i.e. not using average temperatures), when the hottest point on the transformer windings (hot spot) must not exceed 120°C and the oil temperature must not exceed 105°C. In no case is the cyclic rating permitted to exceed 1.3 times the nameplate rating. The normal cyclic rating is the lowest of these four values.

All large power transformer purchases are now specified in accordance with AS 2374.7-1997 so that where possible advantage can be taken of any cyclic loading capabilities. ElectraNet has also on an as needs basis began obtaining comprehensive engineering assessments for large power transformers purchased under older standards that did not specifically allow for cyclic loading. Some of these assessments have shown that it is possible to apply cyclic ratings to some existing large power transformers.

Thermal rating (for lines and cables)

Overhead line ratings are generally determined by the need to maintain minimum clearances from the conductors to ground and were in the past generally calculated in accordance with the ESAA publication D(b)5 – Current Rating of Bare Overhead Line Conductors.

A joint Australian TNSP working group carried out further work in 2005 to review and extend the rating methodology contained in D(b)5 to more accurately model the thermal characteristics of overhead transmission lines. ElectraNet has implemented this modified static line rating methodology.

As the line rating that has been given is the highest normal thermal rating, this would be the winter static rating.

For transmission lines, the winter static rating is calculated based on the line design temperature, with ambient air temperature assumed to be 33°C, a 90° cross-wind of 1 m/s, and a global radiation level of 500 W/m². For spring, autumn and summer ratings, more onerous environmental conditions apply and therefore lower design ratings are achieved.

Notes these ratings are not applied seasonally, but based on ambient temperature.

The line N-1 emergency rating is the line 15 minute rating, this is defined as maximum rating allowed following a single contingency. This rating prevents the conductor from exceeding its as built temperature within 15 minutes, thereby maintaining conductor to ground clearances in accordance with statutory obligations. This is only applied if there is an automatically controlled method of off-loading the line, e.g. via generator re-dispatch.

Underground cable ratings are evaluated on the basis of temperature limits determined by the type of insulation used, method of installation, load-cycle shape, and the presence of other loaded cables nearby. Calculations are undertaken in accordance with IEC 284.

Specific to the new 275kV cable supplying City West, the following ratings have been applied, continuous rating, continuous cyclic rating, emergency cyclic rating and emergency rating. Continuous cyclic rating implies that the cable can be loaded to that rating on a daily basis provided the load curve is of cyclic nature and provides sufficient cooling period for the cable over a set period of time.

A project can have both substation works and lines works, detailed information for both will be included if that component is material. The materiality test is if the component is greater than \$5 million or greater than 10% of the value of the project from the Project cost estimate. This is consistent with the definition provided in the AER's RIN Instructions and Definitions.

Augex asset data – Substations – Table 2.3.1

If no transformer has been added as part of the project, the voltage is the predominate voltage at which the project works have been done at. For example, at a switching station the voltage is the only voltage present in the substation (no transformer hence no secondary voltage).

Primary trigger is listed; secondary triggers are only listed if they do not stem from the primary trigger.

Substation normal cyclic rating reflects the Normal cyclic rating of the substation transformer/s. Where there is more than one transformer such as for a N-1 configuration, the summation of the transformer normal cyclic ratings is given.

Substation N-1 emergency rating is the emergency rating of the substation transformer/s. If there is only one transformer the N-1 emergency rating is 0. Where there is more than one transformer such as for a N-1 configuration the summation of the remaining (in the rare case of differing sized transformers, the largest is taken as the outage element) transformer emergency ratings is given.

Transformer MVA added is the Normal cyclic rating.

All plant and equipment units added are per 3 phase set.

Insulation is taken to be for the external insulation (bushing) not the internal breaking mechanism (i.e. how the phases are insulated from each other and ground).

Earth switches are not counted additionally to the isolator (i.e. insulator with earth switch equals 1, earth switch by itself equals 0 and insulator with double position earth switch equals 1).

Augex asset data – Lines - Table 2.3.2

Primary trigger is listed; secondary triggers are only listed if they do not stem from the primary trigger.

Project type reflects the major works activity for the project (if there are multiple project activities).

Tower upgrade date is not something that is recorded in ElectraNet's Line Schedules database and hence it is only included if it is known from other internal sources.

If there are differing tower / pole types within the line these have been given separate rows (gantries are not included).

Line rating (MVA) is the highest normal thermal rating (not constraining plant). Line N-1 Emergency Rating is the Line 15min rating (if applicable, if not then the highest normal thermal rating). Ratings are done on a per circuit basis.

Where there is more than one line such as for an N-1 configuration the summation of the line ratings is given.

For a "cut in" project the rating is the sum of the capacity of all lines that get connected into the substation. Noting that this figure will only be entered this into the Post section for these cut in type projects as there has been no true uprating works, the "increase" in ratings is only due to the "new" circuit. For the N-1 Post figure the rating of the largest line is subtracted from the total of all the lines connected to the sub.

If it is a radial line, the N-1 emergency rating is 0. Where there is more than one line such as for a N-1 configuration, the summation of the remaining (in the case of differing sized line, the largest is taken as the outage element) line emergency ratings is given. In the case of a mesh network, only directly parallel elements are considered (same to and from nodes).

Financial information source

The information provided by ElectraNet is sourced from ElectraNet's general ledger and projects systems and from internal capital project estimates. The project information is sourced for the duration of each project and covers the years from 2003-04 to 2016-17. Project incurred spend has previously been supplied annually to the AER in Historical Capex reports as part of the Annual Regulated Accounts. ElectraNet has ensured consistency with any information previously reported to the AER and including retention of the project categorisation as previously reported.

Project Costs

This information has been extracted from ElectraNet's project reporting system. ElectraNet has determined the completion of projects by reviewing any planned future spend and by verifying the project status with the Senior Network Project Sponsor. Internal ElectraNet costs charged to projects have been amended to exclude overheads.

Treatment of overheads

The instructions and definitions for the RIN require that overhead costs be excluded from reported project costs.

From 1 July 2010 onwards ElectraNet has incorporated overheads into the team cost centre activity rates which are applied to booked hours as the basis for charging costs to projects and other cost collectors. The activity rates comprise four cost types. These are:

- direct team labour cost – primary cost;
- other direct team expense- primary cost;
- supervisory overhead cost – secondary cost; and
- administration overhead cost – secondary cost.

Primary costs are the first occurrence of charges and generally originate outside the ElectraNet business.

Secondary costs are costs already incurred which are transferred within the business.

The exclusion of overhead from activity rates requires the removal of secondary costs from overhead rates.

ElectraNet has two categories of activity – direct and indirect.

- Direct activities are those which are incurred on operating and maintaining the network and in the construction of assets; and
- Indirect activities support the direct activities – e.g. general business activity, training, compiling policies and procedures.

ElectraNet has two categories of teams. These are direct and support teams. Support teams incorporate supervisory overhead only. After any direct activity charged by these teams, the main portion of the remaining team cost is allocated to the direct teams as administration overhead. This overhead is allocated based on the hours worked by direct teams each month.

Direct team activity rates incorporate all four cost types.

ElectraNet calculates budget activity rates for all teams. From 2015-16, all team rates are actualised each month.

Up to 2015/16 contract labour was incorporated into team activity rates as an oncost. In 2016/17 contract labour was excluded from team rates and for those teams which

employed contract labour, an average team contract labour rate was calculated. Contract labour hours were charged to activities at team contract labour rates.

Exclusion of overhead

ElectraNet has extracted detailed costs from its SAP system from the years 2003-04 to the current reporting year. This information comprises cost centre, cost element, costs, activity hours charged and the partner cost objects, i.e. the receiver or sender of the charge e.g. a capex project.

To calculate team direct cost activity rates, ElectraNet applied its rate calculation methodology to calculate team direct cost rates for both budgeted and actual costs from 2003-04 to the financial year analysed in this year's RINs.

To apply team direct cost activity rates to projects, ElectraNet analysed projects by sending cost centre showing cost and hours charged to each project each year. Team direct rates are applied for each cost centre's annual time booking to each project. Budget team direct rates are applied for support teams for all years and for direct teams for years up to 2009-10. Actual team direct rates are applied for direct teams from 2010-11 to 2014-15 and for all teams from 2015-16 to the financial year analysed in this year's RINs. These rates are multiplied by the related hours charged to derive project costs net of overhead. This information was summarised by project and the difference between full rates and team direct rates calculated, that is, the overhead to exclude from each project for the purposes of RIN reporting.

To apply overhead reduction to project costs, ElectraNet summarised project cost data, where the life of project overhead cost is calculated for each project and applied to give a project cost, net of overhead.

ElectraNet has completed the detailed cost sections in the template with the data requested as determined in the basis of estimation. ElectraNet has analysed the costs for each project based on general ledger accounts, as materials, contracts, external, land & easements and internal costs. Internal direct costs have been calculated, as described above, and are entered together with other external costs in the "other expenditure - other direct" column. Land and easements costs are entered in the "land" and "easements" columns with internal costs for the procurement of land and easements included in the "other expenditure - other direct" column.

After completion of the detailed information, other installation costs, being the balance of construction cost after deducting itemised plant, installation and civil works (i.e. earthworks, fencing, earth grid, fencing, drainage etc.), is entered in a separate row under "Installation (labour)."

Costs are apportioned between substations and lines based on the proportion of lines to other capitalised asset classes.

ElectraNet has derived an average project escalation rate from the annual recorded total project spend using annual March ABS consumer price indices. This has been applied to project \$Nominal costs to convert to \$Real 2012-13.

The year duration of projects, from commencement to completion of expenditure, is entered in the years incurred column.

Augmentation cost for projects less than \$5m for substations and lines are entered in the last row of each table.

ElectraNet has completed *Table 2.3.3* by referencing incurred nominal spend information for the reporting year during the compilation of the annual regulatory financial report. This information summarises incurred spend by project, based on the estimated asset class allocation available before commencement of the project. This data has been re-summarised by asset class, for augmentation projects only, in order to complete this table.

This reconciliation is performed by restating the project close values to \$nominal and listing all augmentation projects to demonstrate the incurred values in relation to the project close values.

Substations

For plant and equipment expenditure (supply) a combination of data sources has been used. Where a capitalisation study has been carried out to the required granularity and the primary plant expenditure has been identified separately, this has been used. Where this is not the case, either ElectraNet's corporate estimating library has been referred to or, purchase order reports, or the Level 3 estimate has been used. The Level 3 estimate incorporates costs submitted by vendors and contracting partners.

For plant and equipment installation labour the source in each case is ElectraNet's corporate estimating library in the Success Enterprise system or the contractor's tender.

For contractor installation costs, the unit rates have been extracted from ElectraNet's corporate estimating library in each case.

In all instances where library data has been used (which uses today's costs), these have then been de-escalated to the relevant period. The de-escalation was conducted based on the annual ABS March All Capitals CPI figure for each year of the relevant period.

Other Items

Where we have identified 'other' items; this typically includes the following works;

Site establishment works including:

- Vehicle access barriers, landscaping and yard lighting;
- Control cabling;
- Rainwater tanks;
- Septic tanks; and
- Decommissioning, demolition alterations and site remediation.

Ancillary items which includes lightning protection, video monitoring, security and marshalling kiosks.

Auxillary power supply including auxillary transformers, local AC supply, diesel generation, power VT's, low voltage AC cable and 11kV cable.

Buildings including control, amenities, storage and telecommunication facilities.

Primary plant equipment including:

- Current transformers;
- Capacitor voltage transformers; and
- Surge arrestors.

Secondary systems including the cost of supply and installation of the following:

- Protection panels;
- Metering;
- Station panels;
- Master OPSWAN panel;
- Remote end protection; and
- SCADA including:
 - Battery banks;
 - PSPM & TWFL;
 - Security and fire alarm systems;
 - Field marshalling kiosks;
 - Telco kiosks; and
 - Brownfield integration.

Telecommunication costs for new sites, associated remote ends and intermediate Bearers including the following:

Site Communications including:

- Fibre/ radio/ PLC;
- MUX S1/S2 (bearer multiplexer);
- MUX P1/P2 (interface multiplexer);
- Protection signalling interface;
- SCADA interface;
- OPSWAN interface;

- Telephony equipment; and
- Monitoring / management equipment.

Site Infrastructure including:

- Site establishment and infrastructure;
- Telecommunications buildings;
- Communication tower and footings;
- AC/DC supplies; and
- Documentation and licences.

Other direct cost including:

- ElectraNet internal cost excluding overhead;
- Other external cost booked directly to the project including consulting costs for project management and the like, travel, meals, compensation to landowners; and
- Outage & generation support.

Related Parties

Related party transactions have been based on transactions with parties that had, have or are expected to have control or influence over ElectraNet's business. For the purposes of this submission this lends itself to being transactions with ElectraNet's shareholders.

From the 2000-01 to the 2010-11 financial year, ElectraNet had a sister entity ElectraNet Transmission Service Pty Ltd. This entity managed procurement for the ElectraNet business on its behalf. All of this expenditure was appropriately charged to ElectraNet Pty Ltd. It had the same shareholders as ElectraNet Pty Ltd but was not a wholly owned subsidiary of the ElectraNet consolidated group of companies. Although under accounting standards, this entity is defined as a "related party" in the interests of identifying the real underlying related party transactions for the RIN, these transactions have been excluded from the related party disclosures.

2.3.3 Basis of estimation

Estimates have been applied to calculate the data presented in template 2.3. Estimates made are described with the data source and methodology section 2.3.2.

2.3.4 Changes to accounting policies

N/A – Information reported within 2.3 of the data template is not impacted by any accounting changes during the reporting period.

2.5 Connections

2.5.1 Data requirement

ElectraNet must report connections expenditure in accordance with the standard approach per the RIN and the capital expenditure reporting approach in the Financial Reporting Framework.

Capital expenditure must reported by year on a “project close” basis, in \$nominal, against the detailed asset categories in the template. All internal costs are to include direct labour only, net of internal overhead costs. The definitions that are specific to connections expenditure are detailed in [Table 2-5](#).

Table 2-5: Definitions Specific to Regulatory Template 2.5 - Connections

Term	Definition
Connection rating (MVA)	Normal cyclic rating.
Connection voltage (KV)	Nominal voltage.
Prescribed connection services	As prescribed in the National Electricity Rules.

2.5.2 Data source and methodology

Table 2.5.1 Expenditure of connection projects

The information provided by ElectraNet is sourced from the ElectraNet general ledger, projects systems and from internal capital project estimates. The project information is sourced for the duration of each project and covers the years from 2003-04 to 2016-17. Project incurred spend has previously been supplied annually to the AER in historical capex reports as part of annual regulated account reporting. ElectraNet has ensured consistency with any information previously reported to the AER and including retention of the project categorisation as previously reported.

Direct materials costs

Direct materials are limited to items of primary plant for expenditure on connection projects.

The primary data source for cost expenditure on the materials component is the CJI3 - Project Cost Actual Line Items Report in SAP.

Items deemed to be a materials resource were identified and totalled for each categorised project. These totals were then input directly into the summary regulatory templates.

Direct labour costs

The RIN instructions and definitions require that only the direct labour component of internal cost is disclosed in data [Table 2.5.1](#). Overhead costs must be excluded from reported project costs.

From 1 July 2010 onwards ElectraNet has incorporated overheads into the team cost centre activity rates which are applied to booked hours for charging costs to projects and other cost collectors. The activity rates comprise four cost types these are:

- Direct team labour cost – primary cost;
- Other direct team expense- primary cost;
- Supervisory overhead cost – secondary cost; and
- Administration overhead cost – secondary cost.

Primary costs are the first occurrence of charges and generally originate outside the ElectraNet business.

Secondary costs are costs already incurred which are transferred within the business.

The exclusion of overhead from activity rates requires the removal of secondary costs from overhead rates.

ElectraNet has two categories of activity – direct and indirect as described below:

- Direct activities are those which are incurred on operating and maintaining the network and in the construction of assets; and
- Indirect activities support the direct activities – e.g. general business activity, training, compiling policies and procedures.

ElectraNet has two categories of teams. These are direct and support teams. Support teams incorporate supervisory overhead only. After any direct activity charged by these teams, the main portion of the remaining team cost is allocated to the direct teams as administration overhead. This overhead is allocated based on the hours worked by direct teams each month.

Direct team activity rates incorporate all four cost types.

ElectraNet calculates budget activity rates for all teams. All teams rates are actualised each month.

Up to 2015/16 contract labour was incorporated into team activity rates as an oncost. In 2016/17 contract labour was excluded from team rates and for those teams which employed contract labour, an average team contract labour rate was calculated. Contract labour hours were charged to activities at team contract labour rates.

Exclusion of overhead

ElectraNet has extracted detailed costs from its SAP system for the years 2003-04 to the current reporting year. This information comprises cost centre, cost element, costs, activity hours charged and the partner cost objects, i.e. the receiver or sender of the charge e.g. a capex project.

To calculate team direct cost activity rates, ElectraNet applied its rate calculation methodology to calculate team direct cost rates for both budgeted and actual costs from 2003-04 to the current reporting year.

To apply team direct cost activity rates to projects, ElectraNet analysed projects by sending cost centre showing cost and hours charged to each project each year. Team direct rates are applied for each cost centre's annual time booking to each project. Budget team direct rates are applied for support teams for all years and for direct teams for years up to 2009-10. Actual team direct rates are applied for direct teams from 2010-11 to 2014-15 and for all teams from 2015-16 to the current reporting year. These rates are multiplied by the related hours charged to derive project costs net of overhead. This information was summarised by project and the difference between full rates and team direct rates calculated, that is, the overhead to exclude from each project for the purposes of RIN reporting.

To apply direct labour to projects, ElectraNet has summarised project cost data, where the accumulated direct labour and overhead cost is calculated for each project and applied to give a project cost, net of overhead. The direct labour costs are entered against projects in *Table 2.5.1*.

Table 2.5.2 Description of connection projects

Data on connection projects inputted to *Table 2.5.1* is sourced from available project management documentation, but primarily from the post implementation report for the project. Ratings are crosschecked with the operational plant ratings database. Other details are reconciled via current network topography (Network single line diagrams i.e. SSD's).

Unless otherwise indicated, 'Connection Rating (MVA)' refers to equipment's normal cyclic rating (for transformers) or highest thermal rating (for lines and cables). ElectraNet has provided its definition(s) of 'normal conditions' in the basis of preparation for section 2.3 Augex.

Where more than one network segment supplies the load such as for a N-1 configuration, the summation of the network segment ratings is provided.

In the case of an uprating project the connection rating shall be the increase in rating delivered by the project.

Connection voltage has been taken to mean the voltage at the high side of the connection transformer, that is, the voltage seen on the ElectraNet side or if applicable the voltage of the line or cable where it is the connection between customers or subsystems.

Underground / Overhead is taken to mean the predominate method of transmission to the connection point on the high voltage side.

Year of connection project completion is on a project close basis.

2.5.3 Basis of estimation

The basis of costs for the materials component for each project is via the CJI3 – Project Cost Actual Line Items Report in ElectraNet ERP – SAP. This report is downloaded and reviewed by a project estimator to identify the material components, which are summarised for input into the template.

Direct Labour Costs

Prior to 1 July 2010 ElectraNet allocated some overheads directly to projects, effectively by-passing the activity rates. Cross allocation to indirect teams and then to direct teams was by journal entry using budgeted overhead cost. This was a complicated process to replicate in order to extract the overhead for the purposes of the RIN therefore ElectraNet has decided to apply the current actual cost methodology to the pre 2010-11 period rates.

2.5.4 Changes to accounting policies

N/A – Information reported within 2.5 of the data template is not impacted by any accounting changes during the reporting period.

2.6 Non-network

2.6.1 Data requirement

ElectraNet is required to report in section 2.6 of the category analysis data template non-network cost information. ElectraNet have provided the collated input data in *Tables 2.6.1, 2.6.2 and 2.6.3* as requested by the AER in accordance with the definitions set out in Appendix F of the RIN shown in *Table 2-6, Table 2-7 and Table 2-8*:

Table 2-6: Annual Non-Network Expenditure - Table 2.6.1

Term	Definition
Motor Vehicles Expenditure	<p>Motor Vehicle Expenditure is defined as all expenditure directly attributable to Motor Vehicles including: purchase, replacement, operation and maintenance of motor vehicles assets registered for use on public roads, excluding mobile plant and equipment. It excludes expenditure on vehicles not generally moved large distances on public roads under their own power. Expenditure on registered vehicles that is not Motor Vehicles Expenditure for this reason should be reported under the Other Non-network expenditure category include: tractors; forklifts; backhoes; bobcats and any other registered mobile plant.</p> <p>All Motor Vehicle Expenditure must be recorded in the Non-Network regulatory template.</p> <p>Sub Categories of Motor Vehicle Expenditure are:</p> <ul style="list-style-type: none"> • Motor Vehicle Expenditure – Cars • Motor Vehicle Expenditure – LCVs • Motor Vehicle Expenditure – HCVs

Term	Definition
	<ul style="list-style-type: none"> • Motor Vehicle Expenditure – Elevated Work Platforms (LCVs) • Motor Vehicle Expenditure – Elevated Work Platforms (HCVs)
Non-network Buildings and Property Expenditure	Expenditure directly attributable to non-network buildings and property assets including: the replacement, installation, operation and maintenance of non-network buildings, fittings and fixtures. It includes expenditure related to real chattels (e.g. interests in land such as a lease) but excludes expenditure related personal chattels (e.g. furniture) that should be reported under Non-network Other expenditure.
Non-network IT & Communications - Non Recurrent Expenditure	IT & Communications - Non Recurrent is all IT & Communications Expenditure that is Non-recurrent Expenditure excluding any expenditure reported under IT & Communications Expenditure - Client Devices Expenditure.
Non-network IT & Communications Expenditure	<p>Is all non-network expenditure directly attributable to IT and communications assets including replacement, installation, operation, maintenance, licensing, and leasing costs but excluding all costs associated with SCADA and Network Control Expenditure that exist beyond gateway devices (routers, bridges etc) at corporate offices.</p> <p>IT & Communications Expenditure includes</p> <ul style="list-style-type: none"> • costs associated with SCADA and Network Control that exist at the Corporate office side of gateway devices (routers, bridges etc). For example, this would include cost associated with SCADA master systems/control room and directly related equipment • IT & Communications Expenditure related to management, dispatching and coordination, etc. of network work crews (e.g. phones, radios etc.). • any common costs shared between the SCADA and Network Control Expenditure and IT & Communications Expenditure categories with no dominant driver related

Term	Definition
	<p>to either of these expenditure categories. For example, a dedicated communications link used for both corporate office communications and network data communications with do dominant driver for incurring the expenditure attributable to either expenditure category should be reported as IT & Communications Expenditure.</p> <ul style="list-style-type: none"> expenditure related to network metering recording and storage at non network sites (i.e. corporate offices/sites). <p>Sub categories of Non-network IT& Communications Expenditure are:</p> <ul style="list-style-type: none"> Client Devices Expenditure Recurrent Expenditure (excluding any client devices expenditure) Non-Recurrent Expenditure (excluding any client devices expenditure)
<p>Non-Network IT & Communications Expenditure - Client Devices Expenditure</p>	<p>Client Devices Expenditure is expenditure related to a hardware device that accesses services made available by a server. Client Devices Expenditure includes hardware involved in providing desktop computers, laptops, tablets and thin client interfaces and handheld end user computing devices including smart phones, tablets and laptops</p>
<p>Non-network IT & Communications Expenditure - Recurrent Expenditure</p>	<p>Is all IT & Communications Expenditure that is Recurrent Expenditure excluding any expenditure reported as: IT & Communications Expenditure - Client Devices Expenditure.</p>

Table 2-7: Annual Descriptor Metrics IT & Communications Expenditure – Table 2.6.2

Term	Definition
<p>Non-network IT & Communication – Descriptor metric - user numbers</p>	<p>Active IT system log in accounts used for prescribed transmission work scaled for prescribed transmission services use (i.e. an account used 50% of the time for prescribed transmission services work equals 0.5 active IT log in accounts)</p>

Term	Definition
Non-network It & Communications – Descriptor metric - device numbers	The number of client devices used to provide prescribed transmission services scaled for prescribed transmission services use (i.e. a device used 50% of the time for prescribed transmission services work equals 0.5 devices). Client Devices are hardware devices that accesses services made available by a server and may include desktop computers, laptops, tablets and thin client interfaces and handheld end user computing devices including smart phones, tablets and laptops.
Non-network IT & Communications Expenditure – Descriptor Metric – employee numbers	The average number of employees engaged in prescribed transmission services work over the year scaled for time spent on prescribed transmission services work (i.e. an employee spending 50% of their time on prescribed transmission services work equating to 0.5ASLs for the purposes of the labour metrics would be 0.5 employees). This metric does not include labour engaged under labour hire agreements.

Table 2-8: Annual Descriptor Metrics Motor Vehicles – Table 2.6.3

Term	Definition
Car	Cars are Motor Vehicles other than those that comply with the definition of Light commercial vehicle, Heavy commercial vehicle, Elevated work platform (LCV), or Elevated work platform (HCV).
Elevated Work Platform (HCV)	Elevated work platforms (HCV) are Motor Vehicles that have permanently attached elevating work platforms that would be HCVs but for the exclusion of elevated work platforms from the definition of HCV.
Elevated Work Platform (LCV)	<p>Heavy commercial vehicles (HCVs) are Motor Vehicles that are registered for use on public roads excluding Elevated Work Platform (HCV)s that:</p> <ul style="list-style-type: none"> • have a gross vehicle mass greater than 4.5 tonnes; or • are articulated Vehicles; or

Term	Definition
	<ul style="list-style-type: none"> are buses with a gross vehicle mass exceeding 4.5 tonnes.
Light Commercial Vehicle	<p>Light commercial vehicles (LCVs) are Motor Vehicles that are registered for use on public roads excluding elevated work platforms that:</p> <ul style="list-style-type: none"> are rigid trucks or load carrying vans or utilities having a gross vehicle mass greater than 1.5 tonnes but not exceeding 4.5 tonnes; or have cab-chassis construction, and a gross vehicle mass greater than 1.5 tonnes but not exceeding 4.5 tonnes; or are buses with a gross vehicle mass not exceeding 4.5 tonnes.

2.6.2 Data source and methodology

2.6.2.1 Non-network expenditure – *Table 2.6.1*

Capex and opex

Capex information is sourced from ElectraNet’s SAP fixed assets and project reporting systems. Capex project data is consistent with historic capex information provided in the Annual Regulatory Financial Reports. Capex is reported in table 2.6.1 on a project close basis as required by the RIN.

Opex information is sourced from ElectraNet’s SAP controlling (cost centre reporting) system. Opex information is consistent with historic expenditure category information provided in the Annual Regulatory Financial Reports. Opex is reported in table 2.6.1 as direct expenditure, comprising purchased materials & services and internal labour costs, excluding allocated overhead which are directly attributable to the required analysis categories.

Capex projects have been reviewed to analyse between device, recurring and non-recurring, for IT & communications (ITC) expenditure and between buildings & property and other for facilities expenditure. Facilities projects have been analysed to allocate cost to furniture and equipment, which is shown as “plant & equipment”, and a purchase of cars, with the balance shown as “buildings and property expenditure.”

Opex expenditure has been analysed by cost element to identify external ITC, motor vehicle and buildings and property expenditure. Internal direct cost (net of overhead) has been similarly analysed, but with an apportionment to buildings and property from the relevant “governance and facilities” cost centres, which was based on activity hours booked. There is minimal internal cost for vehicles and ElectraNet has not apportioned any internal cost to this category.

Treatment of overheads

The RIN does not require that overhead allocations are excluded from the reports expenditure in template 2.10 – Overheads.

2.6.2.2 Annual Descriptor Metrics IT & Communications Expenditure – *Table 2.6.2*

To source current information on number of devices, ElectraNet used information from a number of sources. To establish number of laptop and desktop devices, the Microsoft SCCM (System Centre Configuration Manager) was used. This is ElectraNet's IT asset discovery and management system for hardware and software.

Information on the number of mobile devices was sourced from ElectraNet's internal mobile asset tracking worksheet which is linked to the Telstra MBRS (Telstra Service and Billing) system.

The current number of users was sourced from ElectraNet's Microsoft Active Directory. This directory was queried using system tools software Hyena v8.0. The output from the query run was downloaded to Microsoft Excel and filtered to exclude external users, disabled or expired accounts, email contacts, test accounts and new user templates.

This established the total volume of devices and users currently within ElectraNet as at the end of the reporting period.

2.6.2.3 Annual Descriptor Metrics Motor Vehicles – *Table 2.6.3*

Note all of ElectraNet's vehicles based on the definitions provided in the RIN explanatory statement would be considered cars. ElectraNet does not own or lease any vehicles during the reporting period which would be defined as either a light commercial vehicle (LCV), elevated work platform or heavy commercial vehicle (HCV). Therefore, for these categories ElectraNet has entered zero for each descriptor metric in the data template.

ElectraNet sourced information on volume of motor vehicles from internal fleet management records. This identified for each year of the required reporting period the volume and date of vehicles purchased or leased and identified vehicles traded or returned.

Management of fuel cards and maintenance for all ElectraNet owned and leased vehicles was through fleet management company Custom Fleet for the entirety of the reporting period.

Consistent with the Explanatory Statement, ElectraNet has applied an approximate simple average where the total number of motor vehicles is not constant across a year during the reporting period.

Note that the vehicle volumes entered in the car category for the number purchased, leased and total fleet relates to the entirety of ElectraNet's vehicle fleet. To establish the proportion of the fleet allocated as regulatory expenditure, the number in the vehicle type fleet was scaled to estimate the number of vehicles associated with prescribed transmission services work.

For the purposes of this analysis, the component of total vehicles used for prescribed versus unregulated / other services was split on the basis of the annual total asset base

value apportioned between prescribed and unregulated services for each year of required reporting period.

ElectraNet acknowledge that some vehicles have been leased or purchased for use on specific projects. However, if not utilised for activities associated with the specific project, vehicles are available for use by staff for other unrelated purposes. Therefore, ElectraNet consider that scaling the total fleet number by the proportion of total asset base value from prescribed services work is appropriate in this case.

To establish average kilometres travelled, ElectraNet was provided total kilometres travelled by ElectraNet's vehicle fleet for each year of the reporting period based on Custom Fleet's records. An average kilometre travelled was then calculated by dividing the total kilometres travelled for the year by the average number of vehicles in the fleet for the corresponding year.

To determine the proportion of total fleet expenditure allocated as regulatory expenditure, ElectraNet took annual network operating expenditure on motor vehicles as set out in *Table 2.6.1* and scaled the number by the proportion of total asset base value associated with prescribed transmission services.

2.6.3 Basis of estimation

2.6.3.1 Annual Descriptor Metrics IT & Communications Expenditure – *Table 2.6.2*

The total number of devices identified as at the end of the reporting period was scaled to estimate the number of devices associated with prescribed transmission services work. For the purposes of this analysis, the component of total devices used for prescribed versus unregulated / other services was split on the basis of the annual total asset base value split between prescribed and unregulated services for the required reporting period.

Employee numbers are expressed as number of Full Time Equivalents (FTE) as this measure has been regularly reported to the Board during the reporting period rather than total employee headcount.

2.6.4 Changes to accounting policies

N/A – Information reported within *Tables 2.6.1, 2.6.2 and 2.6.3* of the data templates relates to non-financial information.

2.7 Vegetation Management

2.7.1 Data requirement

Nomination of Vegetation Management Zones

ElectraNet are required to nominate vegetation zones across the geographical area of ElectraNet's network, in doing so considering the following:

- Areas where bushfire mitigation costs are imposed by legislation, regulation or ministerial order; and

- Areas of the network where other recognised drivers affect the costs of performing vegetation management work.

Each contiguous area nominated by ElectraNet is a vegetation management zone.

Accordingly, each part of the network will be covered by only one vegetation management zone. Annual vegetation management expenditure across all categories and zones must equal the total vegetation management expenditure per year.

Unplanned vegetation events table

ElectraNet has provided the data in *Tables 2.7.1, 2.7.2 and 2.7.3* of the template in accordance with the definitions described in Appendix F of the RIN and shown in **Table 2-9**.

Table 2-9: Definitions Specific to Regulatory Template 2.7 - Maintenance

Term	Definition
Audit	Auditing of vegetation management activities (e.g. tree trimming, tree removal, herbicide application, etc.) following vegetation maintenance works in order to confirm the quality and/or extent of the vegetation management activities undertaken.
Average number of trees per maintenance span	The estimated average of the number of trees within ElectraNet’s vegetation maintenance spans. This includes only trees that require active vegetation management to meet its vegetation obligations (it excludes trees that are only inspected).
Contractor liaison	Day-to-day liaison with and management of the contractors involved in undertaking vegetation management work on behalf of ElectraNet. This includes but is not limited to the management of work invoices, assigning work to contractors and the review of audits. This excludes actual audit work undertaken.
Cutting cycle	The average planned number of years (including fractions of years) between which cyclic vegetation maintenance is performed within vegetation management zones.
Defect	A defect is any recorded incidence of noncompliance with ElectraNet’s vegetation clearance standard. This also includes vegetation outside ElectraNet’s standard clearance zone that is recognised as hazardous vegetation and which would normally be reported as requiring management under ElectraNet’s inspection practices.
Inspection	Inspections only for the purpose of identifying of trees or other vegetation that require trimming or removal. This includes vegetation scoping works, the use of LiDAR, aerial and other forms of inspection.
LiDAR	Light detection and ranging

Term	Definition
Maintenance span	A span within ElectraNet’s network that is subject to active vegetation management practices in the relevant year. Active vegetation management practices do not include inspection of vegetation maintenance spans.
Tree	<p>For the purposes of calculating the average number of trees per maintenance span a tree is a perennial plant (of any species including shrubs) that is:</p> <ul style="list-style-type: none"> • equal to or greater in height than 3 metres (measured from the ground) in the relevant reporting period; and • of a species which could grow to a height such that it may impinge on the vegetation clearance space of power lines.
Tree trimming	The activity of cutting back trees or other vegetation to remove dead or living parts so as to prevent parts of the tree or vegetation from growing into, falling onto, or blowing onto electricity assets.
Unplanned vegetation events	System outages and fire starts caused by either vegetation grow-ins or vegetation blow-ins/fall-ins.
Vegetation blow-in/fall-in	<p>An interruption to supply caused by vegetation blowing onto or falling onto network assets. For example wind born branches lodging across the phases of an overhead line, or an adjacent tree falling onto overhead lines.</p> <p>These interruptions to supply may be the responsibility of ElectraNet or other responsible parties such as municipal councils or private land owners.</p>
Vegetation corridor	A tract of land along which vegetation is maintained in order to form a passageway along the route of a power line or lines (e.g. a shared corridor) that is free of vegetation encroachment into the asset clearance space. This does not include portions of the corridor where no managed vegetation exists (e.g. grassland or heathland) or where vegetation is not managed (e.g. deep gullies/valleys where no vegetation management is undertaken). For clarity, the form of tenure, or lack of tenure, over the corridor are not relevant to the existence of a vegetation corridor.
Vegetation grow-in	<p>An interruption to supply caused by vegetation growing into network assets. For example a tree branch contacting overhead lines.</p> <p>These interruptions to supply may be the responsibility of ElectraNet or other responsible parties such as municipal councils or private land owners.</p>

Term	Definition
Vegetation management	<p>Activities that:</p> <p>are primarily directed at removing, altering, or managing vegetation to maintain safe or regulated clearances from distribution or transmission assets; and</p> <ul style="list-style-type: none"> • are not emergency or fault related activities; and • are not initiated by a request from a distribution or transmission customer, excluding customers that are network service providers; and • are not activities for which expenditure could be attributed to the AER expenditure category 'Augmentation, replacement, or non-routine maintenance activities triggered by a changed regulatory obligation or requirement'; and • are not activities for which expenditure could be attributed to the AER expenditure category 'Augmentation, replacement, or non-routine maintenance activities triggered by a changed internal standard'. • include tree cutting, undergrowth control, root management, waste disposal, use of herbicide and growth retardants, and encouragement of low-growth vegetation to prevent the establishment of high-growth vegetation. • includes: <ul style="list-style-type: none"> ○ pre-cutting/trimming inspections; and ○ inspections of vegetation to ensure that activities have been undertaken appropriately; and ○ liaison with affected residents and landowners including the issue of trim/cut notices, and follow up calls on notices; and ○ operational support such as any temporary generation used during the activity; and • does not include: <ul style="list-style-type: none"> ○ such items as "beautification" works, lawnmowing e.g. from nature strips, or office gardens, interior plant and aesthetic vegetation works; and ○ any work done in proximity to non-network assets.
Vegetation management zone	A segment of the transmission network distinguished from other vegetation management segments by material differences in recognised cost drivers.
Width of vegetation corridor	The total width of a vegetation corridor. For clarity, the total width refers to the entire width of the tract of land along which vegetation is maintained.

2.7.2 Data source and methodology

ElectraNet has principally identified vegetation management zones on the basis of bushfire risk areas for the data in *Tables 2.7.1 and 2.7.2*. These bushfire zones are based on the classifications defined in Schedules 3 & 4 of the *Electricity (Principles of Vegetation Clearance) Regulations 2010*. Also, ElectraNet has an additional high bushfire risk area which is a subset of the larger bushfire risk area. This high bushfire risk area has been determined between SA Power Networks (DNSP) and ElectraNet based on historical fire information (such as bushfire events i.e. 1983 Ash Wednesday etc.) and isohyets/regrowth speed.

ElectraNet has included as required by the RIN separate maps at [Appendix A](#) showing:

- Each vegetation management zone; and
- The total network area with the borders of each vegetation management zone.

ElectraNet manages the network with more than one vegetation maintenance span cycle. Routinely, ElectraNet actively manages all spans on a 3 year cycle (as per the *Electricity (Principles of Vegetation Clearance) Regulations*). However, for spans in bushfire and high bushfire risk areas, ElectraNet also performs pre-bushfire season vegetation maintenance on an annual basis to ensure that clearances are maintained.

ElectraNet's vegetation inspection and clearance activities are contracted. ElectraNet's contractor is a provider of vegetation management services to electricity and telecommunications networks throughout Australia. The contractor will cut to the buffer zone if applicable at each cycle.

ElectraNet's self-imposed standards pose no additional cost impact as they are no more onerous than required to ensure compliance with the legislated standards.

2.7.2.1 Descriptor Metrics by Zone – *Table 2.7.1*

Route Line Length within Vegetation Zone - Kilometres

The primary source used to report overhead circuit length and voltage is ElectraNet's Line Schedule database, which contains structure and span information. The information sourced from the database included overhead span lengths, circuits, voltage and section build dates. This is a live database and therefore data downloaded reflects the network status at that moment in time.

Network Statistics Report from the Grazer asset management reporting tool provides an additional source of asset information as well providing a data cross-check. It also provides the different bushfire risk areas. Furthermore, the Network Statistics Report has been used to ensure only regulated and ElectraNet owned lines are included in the line asset list.

The spans are then linked to bushfire risk area via their functional location from the Network Statistics – Spans report (that extracts data from SAP, ElectraNet's integrated business and asset management system). The number of route span lengths assigned as having a bushfire risk is totalled to provide the total route line kilometres for each nominated vegetation zone.

Note that for the purposes of this analysis, underground, unregulated and non-ElectraNet owned lines are excluded.

Number of Vegetation Maintenance Spans

ElectraNet in establishing number of vegetation maintenance spans, relied on information provided and estimated by ElectraNet's vegetation maintenance contractor.

A maintenance Span is defined as a span in ElectraNet's network that is subject to active vegetation management practices during the relevant regulatory year. ElectraNet has included spans requiring tree trimming, removal or scrub removal, but does not include inspection or measuring of vegetation in spans. This is based on expert advice from ElectraNet's vegetation maintenance contractor.

To establish the total number of maintenance spans, ElectraNet have been advised that the contractor reviewed an Access database which contains collated data from inspector and cutting crew worksheets for the regulatory year. This data provided the number of spans that have been actively managed by the contractor throughout the past financial year.

Total Length of Maintenance Spans - Kilometres

Actuals for this measure were only available to the vegetation maintenance contractor, in hardcopy cutting worksheets.

Therefore, to calculate total length of maintenance spans for each period, the number of maintenance spans was multiplied by the average span length for the reporting period for each nominated vegetation management zone.

Average Number of Trees per Maintenance Span

Average number of trees per span has been estimated based on expert advice from the contractor. ElectraNet were advised that the contractor sourced information on number of trees per span from an Access database which provides collated information from daily worksheets from inspectors and cutting crews for the regulatory year.

To estimate the number of trees per vegetation span, ElectraNet were advised that the contractor took the number of trees actively maintained (trimmed, removed or scrub removal) divided by the number of spans requiring vegetation maintenance.

Length of Vegetation Corridors - Kilometres

ElectraNet were advised by the contractor that the whole easement route length is patrolled and where defects are identified these are actioned regardless of terrain. Therefore, for the purposes of this analysis, ElectraNet have determined that for the reporting period length of vegetation corridors is equal to the total route line length.

Average Width of Vegetation Corridors - Metres

Each span has been categorised based on span length and voltage class and the applicable bushfire risk zone, these categorised spans have then had the relevant statutory buffer zones applied.

H (Horizontal mid span clearance), B (Buffer Zone) and S (Step out) measurements are as defined in the Regulations for each voltage and span length.

For the purposes of this analysis, the width of the vegetation corridor is taken to be the maximum vegetation management width, that is, the vegetation management horizontal width at the mid span. (ElectraNet’s understanding is that for ease of cutting, the contractor cuts along the full length at H + any applicable B as shown in figure 2-1). ElectraNet as a rule cuts to the buffer zone therefore the width of the vegetation corridor has been calculated as shown in red in figures 2-1 to 2-6.

For the two bushfire risk regions, the average corridor width has been calculated as S. (Step out + height of tower + 5 metres (isosceles right angle triangle). To establish average tower height, ElectraNet has assumed an average tower height of 20m for 66kV, 30m for 132kV and 40m for 275kV towers. A weighted average is then taken dependant on the voltage and span length within each zone. The average width determined was then doubled to reflect the width of the vegetation corridor on the opposing side of the span.

Note that for 132kv to 275kV lines in Bushfire risk areas as shown in figure 2-4 there is a step out (S) then a 45 degree angle up to the height of the tower + 5 metres.

For non-bushfire risk areas (NBFRA) the width of the vegetation corridor is determined by H + B clearances.

Figure 2-1: Vegetation Clearance Corridor – Non Bushfire Risk Area 33kV to 66kV

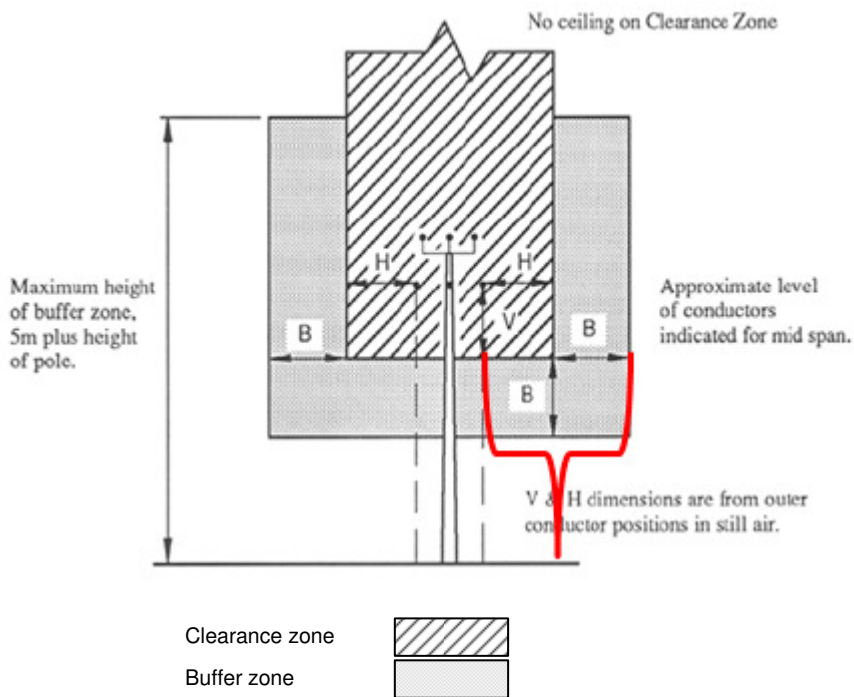

Figure 2-2: Vegetation Clearance Corridor - Non Bushfire Risk Area 132kV to 275kV

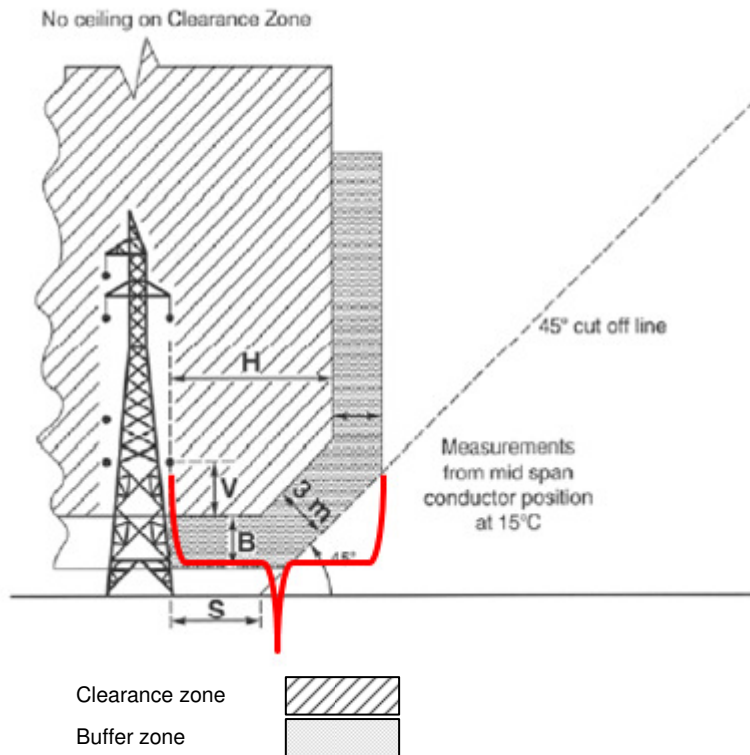

Figure 2-3: Vegetation Clearance Corridor – Bushfire Risk Area 33kV to 66kV

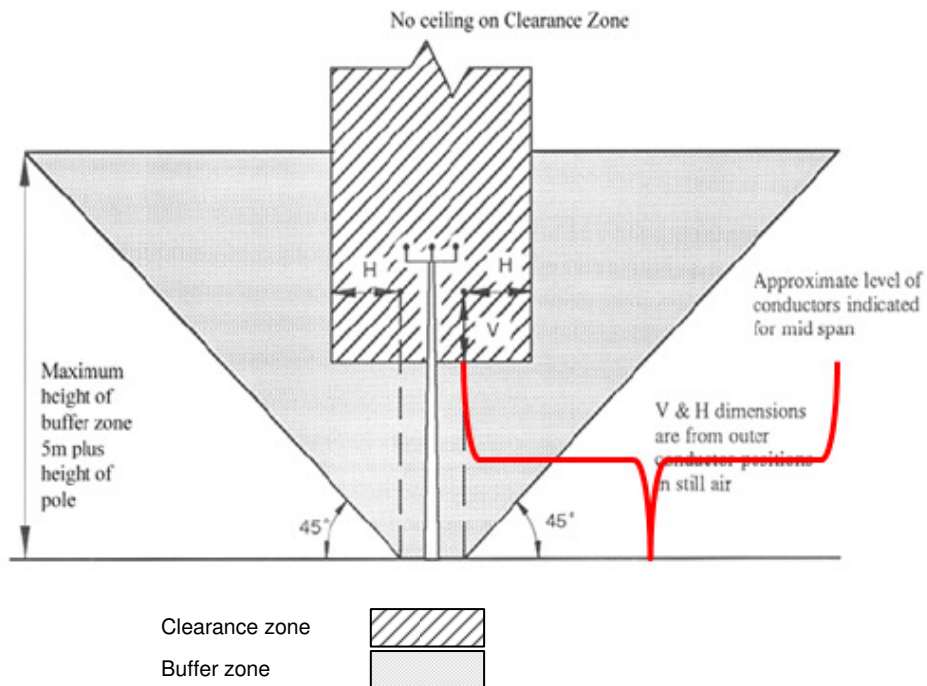

Figure 2-4: Vegetation Clearance Corridor – Bushfire Risk Area 132kV to 275kV

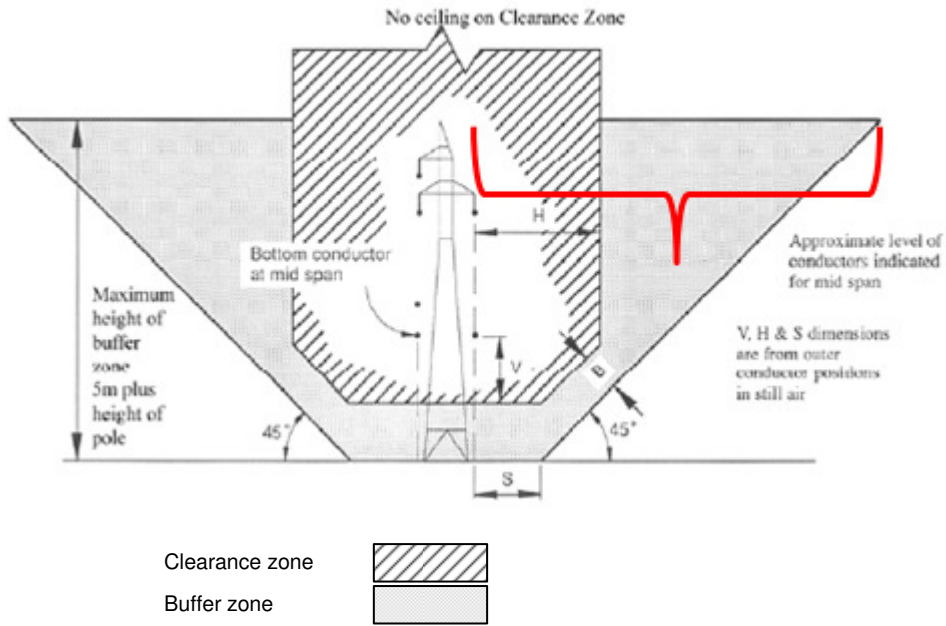
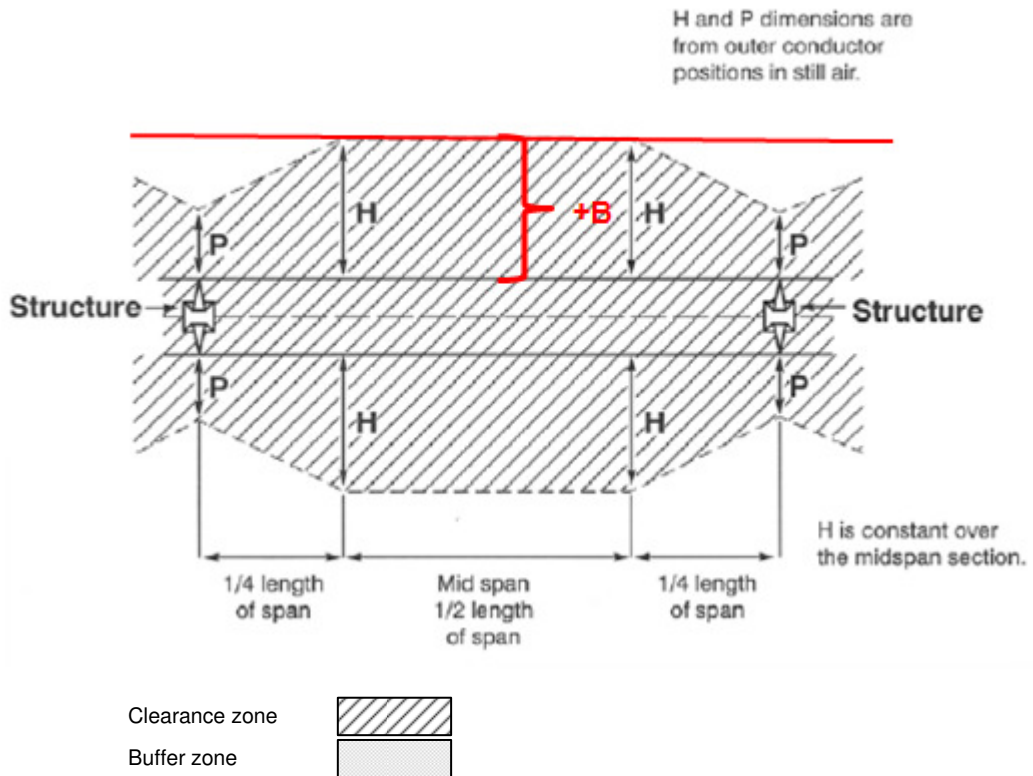

Figure 2-5: Overhead View Vegetation Corridor Clearances



Average Frequency of Cutting Cycle (Years)

ElectraNet operates under more than one vegetation maintenance span cycle. Routinely, ElectraNet actively manages all spans on a 3 year cycle. However, for spans in bushfire and high bushfire risk areas, ElectraNet also performs pre-bushfire season vegetation maintenance on an annual basis. This will have the effect of reducing the overall 3 year cycle for additional maintenance cycles in bushfire risk areas.

2.7.2.2 Expenditure Metrics by Zone – *Table 2.7.2*

Tree Trimming

ElectraNet does not record expenditure on tree trimming separately by the identified vegetation management zones. Therefore, ElectraNet has simply apportioned costs based on route length within each zone identified.

Vegetation Corridor Clearance

ElectraNet does not record expenditure on veg corridor clearance separately this has been included within Tree Trimming. Therefore, ElectraNet has simply apportioned costs based on route length within each zone identified.

Inspection

ElectraNet does not separately record expenditure on inspections of vegetation management corridors. Therefore, ElectraNet has simply apportioned costs based on route length within each zone identified.

Audit

ElectraNet does not separately record expenditure on audits of vegetation management corridors. Therefore, ElectraNet has simply apportioned costs based on route length within each zone identified.

Contractor Liaison Expenditure

Contractor liaison expenditure in the data template reflects ElectraNet's direct internal costs associated with approximately one FTE maintenance program manager. ElectraNet does not record expenditure on Contractor Liaison Expenditure separately by the identified vegetation management zones. Therefore, ElectraNet has simply apportioned costs based on route length within each zone identified.

2.7.2.3 Descriptor Metrics Across all Zones – Unplanned Vegetation Events (*Table 2.7.3*)

In determining the number of outages and fire starts caused by vegetation an extract is taken from an ElectraNet database. This data determines the responsibility and the cause of the event if it was a vegetation blowing, falling or growing into the transmission line. If the cause of the event can not be concluded the event is assumed to be vegetation blowing onto the transmission line.

2.7.3 Basis of estimation

ElectraNet notes that for a negligible number of spans, vegetation management zone information was not defined in the Lines Schedules database. Where the span information for Bushfire risk region was blank, ElectraNet have assumed that it is in a non-bushfire risk region.

A span that spans the border of multiple bushfire regions is assumed to have the highest risk zone which it contains.

The tower itself is assumed to have no width in the determination of the width of the vegetation corridor.

Input data is assumed to be as at 30 June for each year of the required reporting period.

In determining the average width of vegetation corridors, double circuit spans have been counted twice.

In the expenditure metrics by zone (*Table 2.7.2*) a small amount of corrective vegetation costs has been included (~3%) to allow reconciliation to the regulatory accounts. Note that this will not reconcile with section 2.7.1 as this relates to purely routine cyclic work.

ElectraNet does not as yet capture costs separately for Tree Trimming, Corridor Clearance and Inspection. These have been apportioned based on the best estimates by ElectraNet's vegetation maintenance contractor.

2.7.4 Changes to accounting policies

N/A – Information reported within 2.7 of the data template is not impacted by any accounting changes during the reporting period.

2.8 Maintenance

2.8.1 Data requirement

For each standardised asset category, ElectraNet must provide routine and non-routine maintenance expenditure and asset descriptor metrics noting that given the nature of the networks, the asset groups/categories will vary between transmission and distribution.

ElectraNet have provided the collated labour input data in *Tables 2.8.1 and 2.8.2* as requested by the AER in accordance with the definitions set out in Appendix F of the RIN and shown in [Table 2-10](#):

Table 2-10: Definitions Specific to Regulatory Template 2.8 - Maintenance

Term	Definition
Access Track	A path that enables vehicular or foot access to a transmission assets. Where applicable this includes associated pavement, drainage, security (e.g. gates, fences) and animal control devices (e.g. cattle grid). For the purposes of this definition ElectraNet must have a responsibility for the maintenance of the access track and the form of tenure, or lack of tenure, over the maintenance access track is not relevant.
Asset Track Maintenance	Costs of activities to maintain an access track, including inspecting, surveying, auditing, altering, reconfiguring costs or vegetation management costs not involving capital expenditure.
Inspection Cycle	The planned or actual duration between two consecutive inspections of an asset.
Maintenance	Operational repairs and maintenance of the transmission system, including testing, investigation, validation and correction costs not involving capital expenditure.
Maintenance Cycle	The planned or actual duration between two consecutive maintenance works on an asset
Non-routine Maintenance	<p>Costs (opex) of activities predominantly directed at managing asset condition or rectifying defects. The timing of these activities depends on asset condition and decisions on when to maintain or replace the asset, which may vary over time and across NSPs.</p> <p>Activities to maintain asset condition and/or to maintain the capacity of the transmission system to transmit electricity, and where the activities are not routine in nature.</p> <p>The non-routine activities may be undertaken in a discriminate manner for individual assets.</p> <p>Includes emergency response.</p> <p>Excludes routine asset maintenance activities.</p> <p>Excludes activities that are designed to increase or improve the capacity of the transmission system to transmit electricity,</p>

Term	Definition
	<p>except where the increase or improvement is incidental to the maintenance of the transmission system.</p> <p>Excludes asset removal, asset replacement, new asset installation, and vegetation management.</p> <p>May include:</p> <ul style="list-style-type: none"> • activities to inspect, survey, audit, test, repair, alter, or reconfigure assets • functional and intrusive testing of assets, including spares and equipment; <p>Includes load monitoring and switching activities attributable to non-routine asset maintenance.</p>
Protection System	Has the meaning prescribed in the National Electricity Rules
Routine Maintenance	<p>Costs (opex) of recurrent/programmed activities undertaken to maintain assets, performed regardless of the condition of the asset. Costs of activities predominantly directed at discovering information on asset condition, and often undertaken at intervals that can be predicted.</p> <p>Activities to maintain asset condition and/or to maintain the capacity of the transmission system to transmit electricity, and where the activities are:</p> <ul style="list-style-type: none"> • routine in nature; and • indiscriminately carried out for a pre-defined set of assets; and • scheduled to occur at pre-defined intervals. <p>May include activities to inspect, survey, audit, test, repair, alter, or reconfigure assets.</p> <p>A pre-defined interval may be based on the number of times the asset has operated, or any other measure, if the future timing of the maintenance based on the measure can be predicted with a reasonable level of certainty.</p> <p>Excludes activities that are designed to increase or improve the capacity of the transmission system to transmit electricity,</p>

Term	Definition
	<p>except where the increase or improvement is incidental to the maintenance of the transmission system.</p> <p>Excludes asset removal, asset replacement, new asset installation, vegetation management, and emergency response.</p> <p>May include:</p> <ul style="list-style-type: none"> • functional and intrusive testing of assets, including spares and equipment; • helicopter, vehicle, and foot patrols, including negotiation of landowner access; • asset surveys; • environmental testing; • painting of network assets; • re-conductoring lines • indoor and outdoor maintenance of substations including lawn mowing, weed control, fencing; • maintenance of access tracks including lawn mowing, weed control, and maintenance of security structures; <p>Includes load monitoring and switching activities attributable to routine asset maintenance.</p>
<p>SCADA and Communications Systems</p>	<p>Includes all assets that are used to manage, transmit, receive or carry data or voice traffic for the purposes of managing, monitoring or controlling the transmission network.</p> <p>These assets include all equipment used primarily for communications around the network or from network devices to corporate systems and vice versa (e.g. communications to and from equipment and SCADA devices).</p>
<p>Substations</p>	<p>Substation' has the meaning prescribed in the National Electricity Rules.</p>
<p>Transmission lines</p>	<p>Transmission line' has the meaning prescribed in the National Electricity Rules.</p>

2.8.2 Data source and methodology

Base asset information on all maintenance activity groups and asset subcategories defined in the AER's Instructions and Definitions was sourced from the Network Statistics Report which is extracted from ElectraNet's integrated business and asset management system SAP. This report was used to identify key asset information including asset quantity, functional location, asset age, substation start-up date etc.

Information regarding inspection cycles was taken from the SAP maintenance plan which defines the specific routine inspection and maintenance activities required for each asset type. Consistent with the Instructions and Definitions, where multiple inspection and maintenance activities are carried out on an asset type, ElectraNet has for each asset subcategory reported the highest cost activity.

2.8.3 Basis of estimation

Some assumptions were made based on the available data in order to estimate asset quantity, age profile, maintenance activities and expenditure at the asset category level defined in the instructions and definitions.

With regards to routine maintenance costs for transmission lines, costs are applied between 'support structures', 'tower' and 'conductor' for aerial and non-aerial inspections. The allocation applied is 60% structures, 20% towers and 20% conductors for non-aerial services and 80% structures, 10% towers and 10% conductors for aerial services. This split is an estimate based on the experience of relevant ElectraNet personnel.

The count and associated costs of assets relate to regulated assets only. Dates ranges relate to financial year dates beginning 1st July and up to the most recent full financial year ending 30th June.

Line Maintenance - Transmission Towers

In estimating the number of transmission towers at the end of each year of the reporting period, ElectraNet has assumed the following:

- A tower relates to the structures on transmission lines, not substation structures;
- Poles are considered towers, substation towers such as gantries, earth wire poles etc. were excluded from the count;
- Pi structures (2 poles) are considered one tower;
- 3 single phase vertical angle poles are considered as one tower; and
- The count and maintenance costs associated with transmission towers and support structures includes structures on de-energised lines.

In relation to average asset age of transmission towers, the age of structures is based on the original construction age for the relevant built section.

ElectraNet have assumed that all structures are inspected at least annually. For structures in bushfire and high bushfire risk areas it is assumed inspections are carried out prior to the bushfire season and during the bushfire season (i.e. 2 inspections per annum).

ElectraNet has interpreted from the RIN that there is no difference between maintenance and inspections. Furthermore, ElectraNet maintain all transmission lines through inspection and condition monitoring. Where defects are identified, any maintenance is carried out is considered corrective maintenance.

Line Maintenance - Transmission Support Structures

In estimating the number of tower support structures at the end of each year of the reporting period, ElectraNet has assumed the following:

- A support structure relates to the insulator assemblies on the transmission line excluding substation structures;
- Line (suspension) assembly structures have three support structures per circuit on a tower; and
- Brace (tension) assembly structures have nine support structures per circuit on a tower.

Figure 2-6 details these examples of support structures on transmission lines as circled in red.

Figure 2-6: Examples of Support Structures

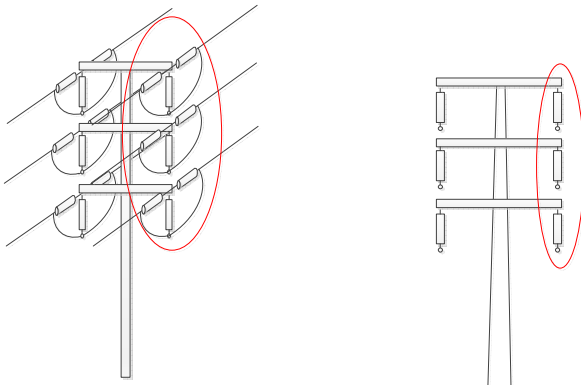

In relation to average asset age of tower support structures, the age of structures is assumed to be that of the original construction date for the relevant built section.

ElectraNet has assumed the same annual inspection rates per year as detailed for transmission towers and that any maintenance carried out is considered corrective maintenance.

Line Maintenance - Conductors

In estimating the number of conductors at the end of each year of the reporting period, ElectraNet has assumed the following:

- A conductor is three phases of a regulated transmission lines. This is irrespective of how many conductors per phase. Note that this definition conflicts with the 'unit of measure' term used in 2.8 of the data template of 'length of route kilometres' as this term would ignore multiple circuit lines.

In relation to average asset, conductors are assumed to have the same age as for structures. ElectraNet are of the opinion that this is reasonable as only a limited amount of re-conductoring has been carried out on transmission lines as repairs.

ElectraNet has assumed the same annual inspection rates per year as detailed for transmission towers and that any maintenance carried out is considered corrective maintenance.

Line Maintenance - Underground Cables

In estimating the length of underground cables at the end of each year of the reporting period, ElectraNet has assumed the following:

- High voltage underground cables which are part of the transmission line feeder system are included; and
- High voltage cables within substations which are used only internally to within the substation are excluded from the calculation.

ElectraNet have assumed that all underground cable routes are patrolled weekly and an alarm and pressure test task is carried out annually. ElectraNet maintain all underground cables through inspection and condition monitoring. Where defects are identified, any maintenance is carried out is considered corrective maintenance.

Line Maintenance – Easements and Vegetation Clearances

In determining route length of easements, ElectraNet has assumed that route length for easements is the same as for transmission lines. ElectraNet acknowledge that there may be some line along roadways, but this is considered to be negligible.

ElectraNet has assumed the same annual inspection rates for easements per year as detailed for transmission towers. Routine vegetation clearance maintenance activities are carried out over the entirety of the network on the basis of a three yearly cycle.

Substation Maintenance - Switching Bays

For the purposes of this analysis, ElectraNet have assumed that the number of switching bays is consistent with the number of substation bays as identified in ElectraNet's SAP asset naming hierarchy.

To establish an average age profile, ElectraNet have assumed that the switching bay age is consistent with the asset start-up date. The count of number of switching bays is from the start-up date.

ElectraNet have assumed that all switching bays are inspected on a four monthly basis. Routine maintenance activities are assumed to be performed on circuit breakers and isolators on a six yearly basis.

Substation Maintenance – Power Transformers

Note that non-regulated and spares were removed from transformer data.

The count of number of power transformers was based on the start-up date. To establish an average age profile, ElectraNet have assumed transformer ages are consistent with the asset start-up date.

ElectraNet have assumed that power transformers are inspected on a four monthly basis and routine maintenance activities assumed to be performed on transformers on a six yearly basis.

Substation Maintenance – Properties

For the purposes of this analysis, property items are considered to be everything within a substation site excluding transformers, switching bays, secondary systems and communication equipment. Property items included in property costs include site establishment items such as Buildings, Earth Grids, Roads, Fences, AC and DC Supplies etc.

The count of number of substation properties is based on the substation start-up date. To establish an average age profile, substation property age is assumed to be the same as the substation start-up date.

ElectraNet have assumed that all substation properties are inspected on a four monthly basis and routine maintenance activities assumed to be performed on Substation Properties on a half yearly basis.

Substation Maintenance – Protection Systems

The count of number of substation protection systems is based on the number of protection scheme functional locations. To establish an average age profile, the protection system age is assumed to be the start date of the most recent equipment associated with the protection functional location.

ElectraNet have assumed that protection systems are inspected on a four monthly basis and routine maintenance activities assumed to be performed on protection systems on a four yearly basis.

SCADA & Network Control

For the purposes of this analysis, ElectraNet have assumed that the AER's definition of SCADA and network control is consistent with ElectraNet's definition of the communications regulatory asset category. ElectraNet have applied this definition to simplify the process of disaggregating the required values from SAP. ElectraNet acknowledge that this approach will not align exactly with the SAP cost assignments as a negligible amount of items will be managed through the secondary systems asset category.

ElectraNet have assumed that the number of SCADA and network control sites is equal to the number of communications sites including those located at substations.

All SCADA and network control sites are assumed to be inspected on a four or six monthly basis. No routine maintenance cycle has been assumed. ElectraNet maintain all communications sites through inspection and condition monitoring. Where defects are identified, any maintenance is carried out is considered corrective maintenance.

2.8.4 Changes to accounting policies

N/A – Information reported within 2.8 of the data template is not impacted by any accounting changes during the reporting period.

2.10 Overheads

2.10.1 Data requirement

Consistent with the requirements in the RIN instructions and definitions, ElectraNet has reported overheads expenditure on the following basis:

- Disclose overhead expenditure before it is allocated to services or to direct expenditure and before any part of it is capitalised; and
- Reported network overhead expenditure under maintenance support, network monitoring & control, asset management support or corporate support.

2.10.2 Data source and methodology

Financial information source

The information provided by ElectraNet is sourced from the ElectraNet general ledger and projects systems. Categorisation is consistent with the operating costs reported to the AER as “Historical expenditure category” reports as part of the Annual Regulated Accounts.

Methodology

Treatment of overheads

The RIN requires that overhead allocations are excluded from the reports expenditure in template 2.10 – Overheads. To achieve this ElectraNet has recalculated activity rates and applied them to all worked hours for the period.

From 1 July 2010 onwards ElectraNet has incorporated overheads into the team cost centre activity rates which are applied to booked hours to charge costs to projects and other cost objects. The activity rates comprise four cost types. These are:

- Direct team labour cost – primary cost;
- Other direct team expense- primary cost;
- Supervisory overhead cost – secondary cost; and
- Administration overhead cost – secondary cost.

Primary costs are the first occurrence of charges and generally originate outside the ElectraNet business.

Secondary costs are costs already incurred which are transferred within the business.

Cost objects are either cost centres, capex projects, opex projects or work orders.

The exclusion of overhead from activity rates requires the removal of secondary costs from overhead rates.

ElectraNet has two categories of activity – direct and indirect:

- Direct activities are those which are incurred on operating and maintaining the network and in the construction of assets; and
- Indirect activities support the direct activities – e.g. general business activity, training, compiling policies and procedures.

ElectraNet has two categories of teams. These are direct and support teams. Support teams incorporate supervisory overhead only. After any direct activity charged by these teams, the main portion of the remaining team cost is allocated the direct teams as administration overhead. This overhead is allocated based on the hours worked by direct teams each month.

Direct team activity rates incorporate all four cost types.

ElectraNet calculates budget activity rates for all teams. All team rates are actualised each month.

Up to 2015/16 contract labour was incorporated into team activity rates as an oncost. In 2016/17 contract labour was excluded from team rates and for those teams which employed contract labour, an average team contract labour rate was calculated. Contract labour hours were charged to activities at team contract labour rates.

Exclusion of overhead

ElectraNet has extracted detailed costs from its SAP system for the reporting period. This information comprises cost centre, cost element, costs, activity hours charged and the partner cost objects, i.e. the receiver or sender of the charge e.g. a capex project.

To calculate team direct cost activity rates, ElectraNet has applied its rate calculation methodology to calculate actual team direct cost rates for the period.

To apply team direct cost activity rates to activities, ElectraNet analysed expenditures by sending cost centre showing cost and hours charged to each receiving cost object. Team direct rates are applied for each cost centre's annual time booking to each cost object. Actual team direct rates were applied for the period. These rates were multiplied by the related hours charged to derive costs net of overhead. Projects may receive activity charges from multiple cost centres and for these an average direct rate or direct / overhead ratio has been calculated for each year.

To apply project and work order overhead reduction to cost centres for opex projects and work orders (mainly maintenance) which settle back to cost centres, the direct cost proportion for each cost object for each year was applied to the settlements received by cost centres, so that the amounts received back from the cost objects are net of overhead for the RIN analysis.

Collation into regulated reporting categories

ElectraNet has aggregated the RIN cost centre data into regulated reporting categories by applying its regulated reporting hierarchy – MAINTBYCAR which has been down-loaded from SAP and configured to apply to the RIN cost information.

Overhead allocation cycles

ElectraNet must also back out secondary cost overhead allocation cycles, which transfer costs from support to direct teams. This leaves overhead cost in the originating cost centres.

Template 2.10

ElectraNet has completed the sections in the template in line with annual reporting to the AER. In each section, for each year, there are three reported items:-

- Regulated overhead expenditure, includes overhead normally charged to capex
- Unregulated overhead expenditure to both capex and opex
- Negotiated overhead expenditure to both capex and opex

The aggregate of the three items in each section is equal to the total ElectraNet overhead cost prior to allocations to regulated capex, and to unregulated and negotiated capex and opex.

2.10.3 Basis of estimation

ElectraNet has presented the RIN information in accordance with the new cost centre mapping as approved in the 2013-2018 revenue reset opex allowance.

2.10.4 Changes to accounting policies

N/A – Information reported within 2.10 of the data template is not impacted by any accounting changes during the reporting period.

2.11 Labour

2.11.1 Data requirement

For each defined overhead category and labour classification levels, ElectraNet must provide historical data labour cost information for prescribed transmission services.

ElectraNet have provided the labour cost information in *Tables 2.11.1 and 2.11.2* as requested by the AER in accordance with the definitions set out in Appendix F of the RIN and shown in [Table 2-11](#) and [Table 2-12](#).

Table 2-11: Labour input classifications

Term	Definition
Executive Manager	A manager responsible for managing multiple senior managers. NSPs typically may have one or more executive managers in areas such as CEO, HR, Finance & Treasury, Legal, Corporate and Network Operations.

Term	Definition
Senior Manager	A manager responsible for managing multiple managers who each manage work teams and projects within the organisation.
Manager	A manager responsible for managing up to full project teams of staff.
Professional	Professional workers who do not have a primary role as staff managers. These may include lawyers, accountants, economists etc.
Semi Professional	Workers with some specialist training supporting fully trained professionals (e.g. draftsperson, bookkeeper etc).
Support Staff	Non-professional support staff not undertaking field work (e.g. clerical support, secretaries).
Intern, junior staff, non-field work apprentice	Interns, junior staff and apprentices undertaking non field work. All apprentices undertaking or training to undertake field work should be reported under Labour Classification Level – Apprentice.
Skilled electrical worker	Fully qualified/trained electrical workers. This will include line workers, cable jointers, electrical technicians and electricians who have completed an apprenticeship.
Skilled non electrical worker	Skilled non electrical worker employed for their skill set. Examples are tradesmen who have completed an apprenticeship such as carpenters, mechanic, painters and arborists.
Apprentice	A field worker employed as part of a government accredited apprenticeship program. This includes all apprentices who will not primarily be working in offices once fully trained (e.g. apprentices training to become electrical workers, fitters and turners, plumbers, painters, mechanics and arborists)
Unskilled worker	Field workers with limited specialist training. This includes workers who have completed short courses with no other qualifications (e.g.

Term	Definition
	labourer, arborist's assistant, traffic controller, meter reader)

Table 2-12: Definitions Specific to Regulatory Template 2.9 – Labour

Term	Definition
<p>Annual ordinary time hours costs - average productive work hours hourly rate per ASL</p>	<p>The regulatory year’s average productive work hours spent on prescribed transmission services hourly rate per ASL for each Classification level including labour costs that are direct on costs related to Labour costs – ordinary time earnings. This includes all direct costs associated with non-productive hours related to ordinary time hours spent on prescribed transmission services (e.g. costs associated with annual leave accrued from working ordinary hours). NSP should indicate what costs are included in each category (1) to (3) directly below. The average hourly wage rate for each year should be calculated by reference to the average number of hours paid as Labour costs – ordinary time earnings for each year and includes costs that are:</p> <ol style="list-style-type: none"> 1. Labour costs - Ordinary time salaries and wages in the year 2. Labour costs – other earnings, on costs, and taxes that are directly related to ordinary time salaries and wages in the year but including allowances.. Fixed costs associated with Labour costs – other earnings, on costs and taxes, for example training, should be reported as costs of ordinary time hours. 3. Labour costs – super that are directly related to ordinary time salaries and wages in the year. 4. Resource contractor costs – the amount of hours worked in the year multiplied by the rate charged by the labour hire company.
<p>Annual ordinary time hours costs - productive work hours per ASL</p>	<p>The average productive work hours per regulatory year per ASL in each Classification level spent on prescribed transmission services work that are Labour costs – ordinary time earnings.</p> <p>All Resource contractor times are classified as ordinary time earnings.</p>
<p>Annual overtime hours costs - productive hours per ASL</p>	<p>The average overtime hours for the regulatory year paid per ASL for each Classification level per year spent on prescribed transmission services. Overtime hours are paid productive work hours that are not Labour costs – ordinary time earnings.</p>

Term	Definition
	<p>Note: for a given classification level average overtime productive work hours per ASL in regulatory year X spent on prescribed transmission services plus average ordinary time earnings productive work hours per ASL in regulatory year X spent on prescribed transmission services should equal average total productive work hours per ASL in regulatory year X spent on prescribed transmission services.</p>
Annual stand down occurrences – total per ASL	The average number of Stand Down Periods per ASL in each Classification Level over the year
Annual totals - ASLs	<p>The number of full-time equivalent employees and staff engaged under labour hire agreements engaged on prescribed transmission services receiving salary or wages (Paid FTE) by the organisation in a given Classification level averaged over the regulatory year. For avoidance of doubt, one full time employee equating to one FTE over the course of the year (for both prescribed transmission services work and other work) that spends 50% of their time on prescribed transmission services work is 0.5 ASL.</p> <p>Resource contractor hours are deemed to be 100% productive and their hours charged for the year as a % of 1957.50 hours determines the ASL equivalent.</p>
Annual totals - average productive work hours per ASL.	The average work hours for the regulatory year per ASL in each Classification level spent on prescribed transmission services work that are productive work hours (i.e. not including non-productive work hours).
Annual totals – total labour costs	The total Labour Costs associated with the total ASLs in a given Classification level
ASL	Average Staffing Level. One ASL is one full-time equivalent employee undertaking prescribed transmission services work receiving salary or wages (Paid FTE) over the entire year. For avoidance of doubt, one full time employee equating to one FTE over the

Term	Definition
	<p>course of the year(for both prescribed transmission services and other work) that spends 50% of their time on prescribed transmission services work is 0.5 ASL.</p> <p>Resource contractor hours are deemed to be 100% productive and their hours charged for the year as a % of 1957.50 hours determines the ASL equivalent.</p>

2.11.2 Data source and methodology

Labour Classifications

To identify ElectraNet employees under each labour classification as per the RIN Instructions and Definitions, a query was run in SAP which provided a list of all active and inactive as at 30 June for the year of the required reporting period. Specifically the database was used to identify for each employee the following:

- Employee name;
- Job type;
- Position ID;
- Division; Team;
- Business unit;
- Occupation benchmark (i.e. standard occupation classification); and
- Employment status (i.e. active or inactive).

ElectraNet have benchmarked positions on the basis of the Australian Classification of Occupations (ASCO), ElectraNet note that the labour classifications provided in the Instructions and Definitions do not necessarily correspond with the classifications in ElectraNet’s employee data. Therefore, from the identified list of employees for each year of the reporting period, ElectraNet, based on relevant management experience mapped the ElectraNet’s defined occupation benchmarks to the RIN labour classification levels as shown in **Table 2-13** below:

Table 2-13: Labour Classification Mapping

ElectraNet Occupation Benchmark	AER Labour Classification
Intermediate clerical	Intern, junior staff, apprentice or Support staff
Advance clerical	Support staff
Associate professionals	Semi professional
Professionals	Professional
Managers	Manager or Senior manager or Executive manager

ElectraNet ran a number of queries within the SAP Business Warehouse to provide the following labour cost information in [Table 2-14](#):

Table 2-14: SAP Business Warehouse Queries – Labour Costs

Data Query (SAP Business Warehouse)	Purpose
Payroll Data Super Query	Provides the majority of the data that makes up labour costs.
Cost Centre Analysis Formatted Query	<p>Provides the remaining data that makes up labour costs, not captured via the Payroll data super query, e.g. Training, employee recognition awards etc.</p> <p>Ensures numbers match to the General Ledger and corresponding cost centre structure utilised in the Basis of Preparation used for Repex (Replacement Capex)</p>
Employee Hours Formatted Query	Provides the basis for work hours
Headcount / FTE Data	Provides the basis for Average Staffing Levels (ASL)

The position identification was used to establish average staffing levels for each labour classification.

ElectraNet are of the opinion that this is appropriate as using position identification means total labour cost and average productive hours will not be impacted by employee movements within the organisation. Therefore average staffing levels, total labour cost and average productive work hours will not move as the employee moves around the organisation.

ElectraNet acknowledge that in a limited number of circumstances a position has become redundant or the position description has changed. This means that all historical information within the payroll data super query changes for the position identification. Therefore, to account for this, ElectraNet has referenced the position identification from the list of active and inactive employees within the Payroll Data Super Query.

Note that where an employee has left the organisation during the required reporting period and has accumulated a large amount of long service leave entitlements, but was still not eligible at the time of their departure, a reversal of long service leave entitlement for the relevant position was incurred.

Corporate v Network Internal Labour Costs

To determine corporate and network internal labour costs, ElectraNet utilised the same classification as described in section 2.2.3 of this Basis of Preparation.

Average Staffing Levels (ASL)

Average staffing levels reported reflect the following:

- Employee = (1 x Utilisation Level) less unpaid leave; and
- Casual employee equals number of worked hours in a month divided by the number of available hours in a month.

Number of FTEs will reflect full time employees and component of the year they worked. For example, if a full time employee started work three months into a reporting year they will be captured as 0.75 of an FTE (i.e. $9/12 = 0.75$).

For casuals it is based on their work hours as a percentage of total hours available in the reporting year.

Total Labour Costs

Total labour costs have been derived on the basis described in section 2.2.3 of this report.

As noted previously, ElectraNet run a payroll data super query in SAP to establish total direct labour payroll costs. Total indirect payroll costs will reflect total labour costs less total direct labour costs.

Total Indirect Payroll Costs have been allocated by position identification based on direct labour payroll costs.

Productive Hours

Productive hours per ASL are based on times sheet entries captured in SAP. ElectraNet sourced employee hours worked via an Employee Hours Formatted Query in SAP.

Note that employee timesheets capture both productive and non-productive hours. The query filtered employee hours to only identify productive hours only. Non-productive hours such as leave and hours associated with unregulated activities have been excluded from the calculation.

In some instances, contractors not classified as casuals will have completed hours in timesheets or appear on the headcount report, but have not been paid via payroll. Costs associated with these contractors have been captured as indirect payroll costs and allocated across all employees as with other indirect costs such as training etc.

Average Productive Work Hours

This analysis reflects the summation of Productive Hours for a fiscal year per ASL.

Productive Ordinary Hours

Productive ordinary hour figures have been derived from total productive work hours less total productive overtime hours.

Productive Overtime Hours

Productive Overtime Hours only account for paid overtime and assume all overtime hours are productive.

Ordinary Time Earnings

For the purposes of this analysis, ordinary time earnings equal total labour costs less overtime earnings.

Overtime Earnings

Overtime earnings represent a minimal component of total productive hours. ElectraNet have identified that overtime hours only represents around less than 0.5% of total hours worked.

ElectraNet acknowledge that overtime paid only reflects direct labour costs. Other attributable costs such as, superannuation and payroll tax are not captured in the cost data. Therefore, ElectraNet has added to overtime earnings additional costs of 9.25% for superannuation and 4.95% for payroll tax have been assumed.

ElectraNet note that the overtime rate is lower than the overall ordinary time rate. This reflects the fact that overtime has typically during the reporting period been undertaken by lower paid employees.

Average Ordinary Hourly Rate per ASL

To establish average ordinary hourly rate per ASL, ElectraNet has divided ordinary time earnings by productive ordinary hours.

Average Overtime Hourly Rate per ASL

To calculate average overtime hourly rate per ASL, ElectraNet divided overtime earnings by productive overtime hours.

ElectraNet note that the following Labour components are not applicable to ElectraNet:

- Executive manager position in the Network Overhead area – All Executive Manager positions reside within the Corporate Overhead area;
- Stand-Down Occurrences – If applicable, it will only impact external contractors;
- Skilled Electrical Worker – External contractors provide this service;
- Skilled Non Electrical Worker – External contractors provide this service;
- Apprentice – External contractors provide this service; and
- Unskilled Worker – External contractors provide this service.

- Resource Contractors have become significant from the 2016/17 year. Therefore data has been extracted from SAP for hours and dollars and this has overlaid the employee data. This results in the number of ASL increasing. All Resource contractor times are deemed productive.

2.11.3 Basis of estimation

Productive Hours

Timesheet data was completed for all ElectraNet employees in the 2016/17 year. For some executives the hours booked were budget hours.

2.11.4 Changes to accounting policies

N/A – Information reported within 2.11 of the data template is not impacted by any accounting changes during the reporting period.

2.12 Input Tables

2.12.1 Data requirement

ElectraNet must report Input Table values in accordance with the standard approach per the RIN definitions and instructions.

Capital expenditure must be reported by year on an incurred basis, in \$nominal, against the detailed asset categories in the template and analysed by spend type. All costs are reported net of internal overhead costs.

Prescribed network and corporate overheads are reported before allocation to capex or to direct opex activities.

Maintenance cost is external contracted cost.

2.12.2 Data source and methodology

The information provided by ElectraNet is sourced from the ElectraNet general ledger and projects systems and from internal capital project estimates.

Capex

Capex project incurred spend has previously been supplied annually to the AER in Historical Capex reports as part of the Annual Regulated Accounts. ElectraNet has ensured consistency with information previously reported to the AER, including retention of the project categorisation as previously reported, but has not adjusted for provision movements for RIN reporting.

The incurred capex for the year relates to projects during their construction phase and ElectraNet has used the same asset class analysis method as used when preparing the annual Regulatory Financial Report. For this, projects are classified using estimates prepared by the ElectraNet estimating team. The allocation to materials, direct labour, contract cost and other is based on analysis of cost element postings to projects and also on analysis of significant projects by asset type. That analysis has been applied to projects within the same project category.

Opex

The information provided by ElectraNet is sourced from the ElectraNet general ledger and projects systems. Categorisation is consistent with the operating costs reported to the AER as “Historical expenditure category” reports as part of the Annual Regulated Accounts.

Methodology

Treatment of overheads

The RIN requires that overhead allocations are excluded from the reports expenditure in template 2.10 – Overheads. For template 2.12 ElectraNet has reported prescribed overheads before allocation to capex or to other opex. To achieve this ElectraNet has recalculated activity rates and applied them to all worked hours for the period.

From July 2010 onwards ElectraNet has incorporated overheads into the team cost centre activity rates which are applied to booked hours to charge costs to projects and other cost objects. The activity rates comprise four cost types. These are

- direct team labour cost – primary cost
- other direct team expense- primary cost
- supervisory overhead cost – secondary cost
- administration overhead cost – secondary cost

Primary costs are the first occurrence of charges and generally originate outside the ElectraNet business.

Secondary costs are costs already incurred which are transferred within the business.

Cost objects are either cost centres, capex projects, opex projects or work orders.

The exclusion of overhead from activity rates requires the removal of secondary costs from overhead rates.

ElectraNet has two categories of activity – direct and indirect.

- Direct activities are those which are incurred on operating and maintaining the network and in the construction of assets.
- Indirect activities support the direct activities – e.g. general business activity, training, compiling policies and procedures

ElectraNet has two categories of teams. These are direct and support teams. Support teams incorporate supervisory overhead only. After any direct activity charged by these teams, the main portion of the remaining team cost is allocated the direct teams as administration overhead. This overhead is allocated based on the hours worked by direct teams each month.

Direct team activity rates incorporate all four cost types.

ElectraNet calculates budget activity rates for all teams. For support teams and direct teams the rates are actualised each month.

Up to 2015/16 contract labour was incorporated into team activity rates as an oncost. In 2016/17 contract labour was excluded from team rates and for those teams which employed contract labour, an average team contract labour rate was calculated. Contract labour hours were charged to activities at team contract labour rates.

Please note that the Resource Contractors do not attract these overheads in 2016-17 as they are not directly employed by ElectraNet but by a labour hire company. The overheads of the labour hire company are effectively incorporated into the charge out rate for these resource contractors.

Exclusion of overhead

ElectraNet has extracted detailed costs from its SAP system for the year. This information comprises cost centre, cost element, costs, activity hours charged and the partner cost objects, i.e. the receiver or sender of the charge e.g. a capex project.

To calculate team direct cost activity rates, ElectraNet applied its rate calculation methodology to calculate team direct cost rates for both budgeted and actual costs. To apply team direct cost activity rates to activities, ElectraNet analysed expenditures by sending cost centre showing cost and hours charged to each receiving cost object. Team direct rates are applied for each cost centre's annual time booking to each cost object. Actual team direct rates are applied for the reporting period. These rates are multiplied by the related hours charged to derive costs net of overhead. Projects may receive activity charges from multiple cost centres and for these an average direct/overhead ratio was been calculated for the year. To apply project and work order overhead reduction to cost centres, for opex projects and work orders (mainly maintenance) which settle back to cost centres, the direct cost proportion for each cost object for each year was applied to the settlements received by cost centres, so that the amounts received back from the cost objects are net of overhead for the RIN analysis.

Collation into regulated reporting categories

ElectraNet has aggregated the RIN cost centre data into regulated reporting categories by applying its regulated reporting hierarchy – MAINTBYCAR which has been down loaded from SAP and configured to apply to the RIN cost information.

Overhead allocation cycles

ElectraNet must also back out secondary cost overhead allocation cycles, which transfer costs from support to direct teams. This leaves overhead cost in the originating cost centres.

Templates 2.12

ElectraNet has completed the sections in the template in line with annual reporting to the AER. Items are reported as follows:-

- Maintenance costs are as previously reported in templates 2.7 and 2.8. All ElectraNet maintenance cost is contracted.
- Network and overheads – network cost categories excluding direct maintenance. Direct – as reported in template 2.10
- Corporate overheads – as reported in template 2.10
- Capex – augmentation, connections and replacement on an “as incurred” basis
- Non-network expenditure – capex only, on an “as incurred” basis.

Related party transactions are between ElectraNet and its directors as disclosed in the Annual Regulatory Financial Report.

2.12.3 Basis of estimation

Labour costs for opex and capex are extracted from the internal preliminary workings files. ElectraNet does not track direct labour expenditure in its accounting systems. Direct labour is the main component of hourly activity rates. The process of estimation is as described above under methodology.

Materials, contract and other costs for augmentation, connections and replacement capex are based on project cost estimates prepared by the ElectraNet estimating team which has derived project cost splits between material, contract, other external and internal costs. ElectraNet does not have detailed analysis from suppliers of the split between materials, contract and other costs, because many capital projects are executed on a supply and build basis.

ElectraNet has presented the RIN information in accordance with the cost centre mapping as approved in the 2013-2018 revenue reset opex allowance.

2.12.4 Changes to accounting policies

N/A – Information reported in data template 2.12 is not impacted by any accounting changes during the reporting period.

5. Asset and Demand Information

5.2 Asset Age Profile

5.2.1 Data requirement

Consistent with the requirements in the RIN instructions and definitions, ElectraNet has reported asset age profile information on the following basis:

Table 5.2.1 instructions:

- a) *Where ElectraNet provides asset sub-categories corresponding to the prescribed asset categories in table 5.2.1, ElectraNet must ensure that the expenditure and asset replacement / asset failure volumes of these sub-categories reconcile to the higher level asset category. ElectraNet is required to insert additional rows and provide a clear indication of the asset category applicable to each sub-category. ElectraNet must provide corresponding replacement expenditure data in regulatory template 2.2 as per its respective instructions.*
- b) *In instances where ElectraNet is reporting expenditure associated with asset refurbishments/ life extensions capex it must insert additional rows at the bottom of the table for the relevant asset group to account for this. ElectraNet must provide the required data, applying the corresponding asset category name followed by the word "REFURBISHED". ElectraNet must provide corresponding replacement expenditure data in regulatory template 2.2 as per its respective instructions.*
- c) *In instances where ElectraNet considers that both the prescribed asset group categories and the asset sub-categorisation do not account for an asset on ElectraNet's transmission system, ElectraNet must insert additional rows below the relevant asset group to account for this. ElectraNet must provide the required data, applying a high level descriptor of the asset as the category name. The section item titled "OTHER BY" illustrates this requirement. ElectraNet must provide corresponding replacement expenditure data in regulatory template 2.2 as per its respective instructions.*
- d) *In instances where ElectraNet wishes to provide asset sub-categories in addition to the specified asset categories in table 5.2.1, ElectraNet must provide a weighted average asset economic life, including mean and standard deviation that reconciles to the specified asset category in accordance with the following formula:*

Economic life of asset category

$$= \sum_{i=1}^n \left(\frac{\text{value of asset sub - category}_i}{\text{total value of asset category}} \right) \times \text{economic life of asset sub - category}_i$$

where:

n is the number of sub-categories to reconcile with the asset category

Asset values are determined by the asset category's contribution to the current replacement cost of the network. This being the most recent per unit cost of replacement for each asset, multiplied by the number of those assets in service and reported in the asset age profile.

Table 5-1: Definitions Specific to Regulatory Template 5.2 – Asset Age Profile

Term	Definition
Asset refurbishments/ life extension capex	The non-demand driven capex to restore an asset to its former functionality where the asset has reached the end of its economic life. The works undertaken must result in a material extension in the expected life of the asset
Circuit breaker	A switch that can open under fault current conditions to protect equipment and electrical circuits from damage.
Conductors	These assets have the primary function of transmitting power, above ground, within the transmission network. It excludes any assets that are included in any other asset category.
Current Transformers	transformers used to measure current for protection or measurement purposes.
Gas Insulated Switchgear Unit	enclosed gas insulated switchgear that may comprise circuit breakers, disconnectors, isolators, and other gas insulated components.
Isolators/disconnectors	switches used to de-energise and isolate equipment or portions to the electrical network to allow service or maintenance to be undertaken.
Multiple circuit configuration	A multiple circuit configuration is a transmission line that includes more than one electrical circuit.
SCADA and Network Control and Protection systems replacement	Replacement expenditure associated with SCADA and network control hardware, software and associated IT systems. Includes replacement of protection and control systems and communication systems. This excludes all costs associated with SCADA and Network Control Expenditure that exist within gateway devices (routers, bridges etc.) at corporate offices. Protection systems has the meaning prescribed in the National Electricity Rules
Single circuit configuration	A single circuit configuration is a transmission line that has one set of conductors that are operated as a single electrical circuit. However, for the purposes of this definition, where a line has been constructed as a

Term	Definition
	multi-circuit line but operates as a single circuit line, it should be included as a multi-circuit line.
Substation power transformers	<p>These are assets used to transform between voltage levels within segments of the network.</p> <p>This includes all its components such as the cooling systems and tap changing equipment.</p> <p>It excludes any assets that are included in any other asset group.</p> <p>For the avoidance of doubt, this does not include instrument transformers as defined in the National Electricity Rules.</p>
Substation reactive plant	<p>These are assets used to support the transfer of real power across the network. This includes reactors, synchronous condensers, shunt capacitors, static VAr compensators, dynamic VAr compensators.</p> <p>It excludes any assets that are included in any other asset group.</p>
Substation switchbays	<p>These are all assets used to provide switching within the substation and includes disconnect switches, circuit breakers, current transformers, voltage transformers and associated busbars and steelwork.</p> <p>It excludes any assets that are included in any other asset group.</p>
SVCs (Static VAR compensators)	Has the meaning prescribed in the National Electricity Rules.
Transmission cables	<p>These assets have the primary function of transmitting power, below ground, between segments of the network.</p> <p>This includes the material primarily used to transmit the power and cable ends, joints, terminations and associated hardware and equipment (e.g. surge diverters, etc.), cable tunnels, ducts, pipes, pits and pillars.</p> <p>It excludes any assets that are included in any other asset group.</p>
Transmission towers	These are vertically oriented assets that provide load bearing structural support for conductors or other lines assets. This also includes associated transmission tower support structures, insulators, earthing, footings, where these are replaced in conjunction with a

Term	Definition
	transmission tower replacement project. It excludes any assets that are included in any other asset group.
Transmission Tower Support Structures	These are horizontally oriented structures and their components that provide support for conductors or other line assets to be located on a transmission tower and provide adequate clearances. This expenditure relates to that which TNSPs incur when transmission tower support structures are replaced independently of the transmission tower they are located on. This includes tower section, arms, insulators, earthing It excludes any assets that are included in any other asset group.
Voltage Transformers	transformers used to measure voltage levels for protection or measurement purposes.

5.2.2 Data source and methodology

Historically ElectraNet has not reported an asset’s economic life on the basis defined in the instructions and definitions. Therefore, ElectraNet have reported the economic life of each asset category on the basis of the standard useful lives. ElectraNet engaged Maunsell Australia Pty Ltd to prepare expert advice to determine for each asset category a standard asset life which was submitted to the AER by ElectraNet as part of ElectraNet’s 2008-13 revenue reset proposal (the “Maunsell Report”). This is the basis for ElectraNet’s economic life used for each asset category. Note that standard useful lives used in the economic life calculation are those as approved by the AER in the recent 2013-18 revenue reset determination (Table 6.3 AER Final Decision ElectraNet 2014-15 to 2017-18).

Many of the asset categories that the AER has requested are subcomponents that make up these composite assets classes, and many of these may have differing lives to the parent class, for example, SVC’s contain very major electronic secondary systems which will have different lives to the “substation primary plant” 44.8 year class. In this case if provided in the Maunsell Report the recommended asset lives for those subcomponents are used, and if not the overarching regulatory asset class is used.

ElectraNet notes asset lives depend on many factors such as design quality and construction, the loading and mechanical and electrical stresses, environmental conditions, maintenance practices etc. etc. Whilst each asset will have their own individual lives, ElectraNet believe generic figures are appropriate for valuation and planning purposes given assets of similar duties and operating regimes and a comprehensive asset management plan.

ElectraNet for determination of the standard deviation of economic life has used the methodology proposed in AER document “Electricity network service providers – Replacement expenditure model handbook” Nov 2013 page 19 which states, “A common occurrence in this regard is the standard deviation for the replacement life is not provided – normally owing to this not being known by the NSP. In these circumstances, the standard deviation can be set to the square root of the mean life. This approximation may, however, overstate the standard deviation”

Note the Installed asset date is as requested by the AER as energisation/commissioning date hence these may not match assets reported in other sections of the RIN that are on a project close basis.

Asset information is derived from the Network Statistics Report that extracts data from SAP. This contains information on size/dimension, voltage, start-up date, regulated status and technical object type.

ElectraNet used the internal Plant and Line Rating database as the source to determine the seasonal thermal normal ratings for all regulated lines.

Table 5.2.1 – Asset age profile

Transmission Towers

To determine the number of circuits per structure the line schedule by feeder report is interrogated in the Network Statistics Report. Structures that report multiple times for different feeders (circuits) are regarded as multiple circuits.

In estimating the number of transmission towers at the end of each year of the reporting period, ElectraNet has assumed the following:

- A tower relates to the structures on transmission lines, not substation structures;
- Poles are considered towers, substation towers such as gantries, earth wire poles etc. were excluded from the count;
- Pi structures (2 poles) are considered one tower;
- 3 single phase vertical angle poles are considered as one tower; and
- The count of transmission towers only relates to regulated structures.

In relation to average asset age of transmission towers, the age of structures is based on the original construction age for the relevant built section.

De-energised lines are included in the provided figures. This is as these lines can be returned to service quickly with minor works and these sections are still maintained.

Multiple circuits include both double and triple circuit towers.

Voltage is the highest voltage if there are multiple circuits of differing voltages.

Asset economic life is the standard useful asset life for the “transmission lines - overhead” class.

Conductors

Circuit rating from the Plant and Line Rating database is linked to the feeder via a lookup on the unique feeder number in the Network Statistics Report.

Conductor has been defined as the circuit kilometres of conductor by built section. A conductor is three phases of regulated transmission line. This is irrespective of how many

conductors per phase and excludes earth wires. Circuit length comes from the line schedule SQLite database report query BSCircuitlength.

Line rating (MVA) is the highest normal thermal rating of the circuits within the built section (not constraining plant).

Conductors are assumed to have the same age as the built section. ElectraNet are of the opinion that this is reasonable as only a small amount of re-conductoring has been carried out on transmission lines.

De-energised lines are included in the provided figures. This is as these lines can be returned to service quickly with minor works and these sections are still maintained. The rating that the line would have if it is re energised if this is not available it is zero.

Asset economic life is the standard useful asset life for the “transmission lines - overhead” class.

Underground cables have been excluded.

Cables

To determine the insulation of some cables Grazer, the asset management tool was queried in addition to the Network Statistics Report.

A cable has been defined by the circuit kilometres of cable. A cable is three phases of regulated underground cable. This is irrespective of how many conductors per phase.

High voltage underground cables which are part of the transmission line feeder system are included; and High voltage cables within substations which are used only internally to within the substation are excluded from the calculation.

Asset economic life is the standard useful asset life for the “transmission lines - underground” class.

66 kV Cables have been included in this section.

Air Insulated Circuit Breaker

GIS breakers have been removed from the count in the Network Statistics Report.

ElectraNet has applied the SF6 Circuit Breaker asset age of 42 years as these circuit breakers are the main type used throughout ElectraNet’s network.

Load switches have been excluded.

Air Insulated Isolators / Earth Switch

GIS isolators have been removed from this count in the Network Statistics Report. Additionally, Earth switches are not counted separately to isolators (i.e. insulator with earth switch equals 1, earth switch by itself equals 0, insulator with double position earth switch equals 1).

The air insulated isolator/ earth switches asset economic life is the standard useful asset life for the “substation primary plant” class.

Fault throwing switches were excluded.

VT

The asset count derived from the Network Statistics Report included voltage transformers (ITVT) and capacitor voltage transformers (ITCVT). The report classifies voltage and capacitor transformers as single units when they are grouped in threes therefore the count has been divided by three to be consistent with the assumption that is all assets are by per 3 phase set. VT's at a voltage less than 10kV have been excluded as they do not provide a transmission function.

The VT standard asset economic life is based on expert advice.

CT

The asset count from the Network Statistics Report includes current transformers (ITCT) and combined current and voltage transformers (ITCTVT). The report classifies current transformers as single units when they are grouped in threes therefore the count has been divided by three to be consistent with the assumption that is all assets are by per 3 phase set.

Furthermore, the following are excluded as they do not provide a transmission function

- internal cap balance VT's and CT's at a voltage less than 10kV;
- Leakage or neutral Overcurrent CT's

Combined CT & VT's are classed as CT's (this is as CT's are generally the more expensive piece of plant due to their construction techniques). Asset economic life is based on expert advice.

GIS Module

The asset count includes any GIS Module that has a circuit switching element which is gas insulated. This is consistent with the definitions carried through RIN but is not inclusive of standalone Earth switches.

Asset economic life is the standard useful asset life for the “substation primary plant” class.

Substation Power Transformers

The asset count for transformers has applied the highest transformer nameplate rating with forced cooling if available (ODAF). Additionally, the asset count excludes AC supply Transformers as these do not provide a transmission function (site auxiliary function), but includes SVC transformers and Tie (Transmission) Transformers.

Asset economic life is the standard useful asset life for the “substation primary plant” class.

Transformer refurbishment will not have a line item (as in section 2.2) as this date information is not recorded to the asset (only original energisation).

SVCS

The SVC unit count is defined by the associated step up transformer. In the substation power transformers section search on equipment location (SVC).

Asset economic life is the standard useful asset life for the “substation primary plant” class.

Capacitor

Where the report classifies capacitors down to the single phase unit the count must be made consistent with the assumption that is all assets are by per 3 phase set. These can be identified by the phase code letters.

Asset economic life is the standard useful asset life for the “substation primary plant” class.

Oil Filled Reactors

The asset count includes only oil filled reactors. Additionally, air cooled reactors that are used in applications that would typically require oil filled reactors, such as network voltage control are included within this category. However, other Air cooled reactors that are used for the applications that would typically require air cooled reactors such as fault level control, inrush or harmonic filtering purposes are excluded.

Asset economic life is the standard useful asset life for the “substation primary plant” class.

SCADA, Network Control and Protection

The basis that SCADA, Network Control and Protection were broken up in section 2.2 of the RIN was consistent with categories on the basis of ElectraNet’s internal project estimating tool at a high level. It has been assumed that category is only split into function for major capital works. For these high level categories giving an installed asset profile would not be very meaningful and would look similar to the site establishment profile.

Total Secondary Systems

Secondary Systems have been defined as an age count of all protection schemes. Apart from Telecommunication (SCADA and control) which is treated separately this will cover the vast majority of secondary systems.

The count of substation protection systems is based on the number of protection scheme functional locations. To establish the age profile, the protection system age is assumed to be the start date of the most recent equipment associated with the protection functional location.

Asset economic life is the standard useful asset life for the “Substation secondary systems - electronic” class. This is because electronic devices (electronic and digital) are the primary type in the ElectraNet network.

Telecommunications

For the purposes of this analysis, ElectraNet have assumed that the AER’s definition of SCADA and network control is consistent with ElectraNet’s definition of the communications regulatory asset category. ElectraNet have assumed that the number of

SCADA and network control sites is equal to the number of communications sites including those located at substations.

The count of substation properties and standalone comms sites is based on the original site start-up date.

Asset economic life is the standard useful asset life for the “Substation secondary systems - electronic” class. This is because electronic devices (electronic and digital) are the primary type in the ElectraNet network.

Site Establishment

Site establishments have been defined as an age count of all substation (substation and switching station) sites.

The count of substation (not including standalone comms sites or weather stations) properties is based on the original substation start-up date.

Asset economic life is the standard useful asset life for the “substation establishment” class.

OPGW

OPGW is defined as the circuit kilometres of OPGW.

Asset information has been collated and cross checked from SAP, the line schedule database, and information provided by the Principal Engineer Telecommunications.

From SAP query IH06 by all 4th level built section Function locations containing “OPGW”. These are then linked via functional location to the span connectivity in the line schedule to obtain span lengths. In the line schedules database, spans are filtered by earthwire size for known OPGW types. These unique span lengths are then added together.

The start-up date for the OPGW circuit used is as available in SAP if unavailable, the year of construction has been provided by the Principal Engineer Telecommunications, Network Strategies. Where no better information is available OPGW is assumed commissioned on the 1st of Jan of the start-up year.

Asset economic life is the standard useful asset life for the “Transmission line refit” class. This is because OPGW at ElectraNet is primarily used as a retrofit earth wire on existing transmission lines.

OPGW is included if it is installed, regardless of if it is being used for communication purposes. Buried fibre is excluded.

5.2.3 Basis of estimation

Note that the asset age profile is based on regulated assets only, spares have been excluded.

Insulation type is taken to be for the external insulation (bushing) not the internal breaking mechanism (i.e. how the phases are insulated from each other and ground).

All plant and equipment units added are per 3 phase set.

Input data is assumed to be as at 30 June for each year of the required reporting period.

5.2.4 Changes to accounting policies

N/A – Information reported within 5.2 of the data template is not impacted by any accounting changes during the reporting period.

5.3 Maximum Demand Network Level

5.3.1 Data requirement

Table 5.3.1 of the data template must be completed in accordance with the RIN in particular Appendix E and Appendix F.

ElectraNet must provide inputs for the appropriate cells if it has calculated historical weather corrected maximum demand. Where ElectraNet does not calculate weather corrected maximum demand it may estimate the historical weather corrected data or shade the cells black. For Regulatory Years 2015 and thereafter ElectraNet must provide weather corrected maximum demand in accordance with best regulatory practice weather correction methodologies.

ElectraNet does not calculate weather corrected maximum and has received this data from SA Power Networks. For ElectraNet's direct connect industrial customers, ElectraNet has accounted for diversity in the 10% and 50% POE coincident demands. The methodology is described in the Maximum Demand and Utilisation Spatial.

ElectraNet must provide inputs for 'Embedded generation' if it has kept and maintained historical data for embedded generation downstream of connection points and if it accounts for such embedded generation in its maximum demand forecast.

If ElectraNet has not kept and maintained historical data for embedded generation downstream of connection points, it may estimate the historical embedded generation data or shade the cells black. For Regulatory Years 2015 and thereafter ElectraNet must provide embedded generation data. It must do similarly if it accounts for embedded generation in its system level maximum demand forecast.

For Subsequent Regulatory Years ElectraNet will be required to provide Weather Adjusted Maximum Demand on an ongoing basis in accordance with best regulatory practice weather adjustment methodologies.

ElectraNet has not kept and maintained historical data for embedded generation downstream of connection points and has received this data from SA Power Networks.

5.3.2 Data source and methodology

ElectraNet has received the 10 % and 50 % POE weather adjustments from SA Power Networks. Embedded generation has been estimated see section 5.4.3.

For ElectraNet's direct connected customers (excluding the NSP SA Power Networks), National Grid Metering (NGM) data on which the NEM financial settlement is based has been used. This has been previously Quality Controlled by the Metering Data Agent

(meter reader) and by AEMO prior to use in NEM settlement. It is also checked weekly by ElectraNet's internal processes.

For the avoidance of doubt the raw network level coincident maximum demand is consistent with the coincident system maximum demand specified in the Economic Benchmarking RIN and is sourced from the same data source.

Raw Network Level coincident maximum demand was worked out by firstly summing all the half hour MW demands in the network at connection point level over the financial year and then by identifying the maximum summation of that final year. The time and date of the maximum summation were also noted and compared with the "summer peaking" and "winter peaking" definition to work out the peaking season.

5.3.3 Basis of estimation

ElectraNet's large industrial customers are not weather dependant. This makes estimations of non-coincident 10 and 50 percent POE neither possible, nor appropriate, using weather corrected maximum demand methodology. ElectraNet does not have sufficient historical information with appropriate baselines (baselines change before sufficient history can be captured) to determine the 10 % and 50 % POE values for these customers using an alternative methodology. ElectraNet has estimated the 10 and 50 POE numbers from the customer's maximum usage over the most recent year.

ElectraNet has estimated the coincident 10% POE and 50% POE. This has been explained in the section: Maximum Demand and Spatial Utilisation; Basis of estimation.

5.3.4 Changes to accounting policies

N/A – Information reported within Table 5.3.1 relates to non-financial information.

5.4 Maximum Demand and Utilisation Spatial

5.4.1 Data requirement

Instructions for regulatory template 5.4.1:

In *Table 5.4.1*, ElectraNet must input maximum demand information for connection points.

8.7 ElectraNet must insert rows into the tables for each of its connection points. ElectraNet must note instances where it de-commissions components of its network belonging to that segment in the basis of preparation.

8.8 Where maximum demand in MVA occurred at a different time to maximum demand in MW, ElectraNet must enter maximum demand figures for both measures at the time maximum demand in MW occurred. In such instances, ElectraNet must enter the maximum demand in MVA in the basis of preparation, noting the regulatory year in which it occurred.

8.9 If either the MW or MVA measure is unavailable, calculate the power factor conversion as an approximation based on best engineering estimates.

8.10 If ElectraNet cannot use raw unadjusted maximum demand as the basis for the information it provides in table 5.4.1, it must describe the methods it employs to populate those tables. See clause 3.4(d) for further guidance.

8.11 *ElectraNet must input the connection point rating. For table 5.4.1 rating refers to normal cyclic rating.*

(a) ElectraNet must provide the seasonal rating that corresponds to the time of the raw adjusted maximum demand. For example, ElectraNet must provide the summer normal cyclic rating of the network segment if the raw adjusted maximum demand occurred in summer.

(b) Where ElectraNet does not keep and maintain connection point rating information (for example, where the DNSP owns the assets to which such ratings apply), it may estimate this information or shade the cells black.

8.12 *ElectraNet must provide inputs for 'Embedded generation' if it has kept and maintained historical data for embedded generation downstream of the connection point and/or if it accounts for such embedded generation in its maximum demand forecast.*

(a) ElectraNet must allocate embedded generation figures to the appropriate connection point under system normal conditions (consistent with the definition of raw adjusted maximum demand).

(b) ElectraNet must describe the type of embedded generation data it has provided. For example, ElectraNet may state that it has included scheduled, semi-scheduled and non-scheduled embedded generation in the tables for connection points. In this example, we would be able to calculate native demand by adding these figures to the raw adjusted maximum demand figures.

(c) If ElectraNet has not kept and maintained historical data for embedded generation downstream of the connection point, it may estimate the historical embedded generation data or shade the cells black. For Regulatory Years 2015 and thereafter ElectraNet must provide embedded generation data. It must do similarly if it accounts for embedded generation in its spatial maximum demand forecast.

8.13 *ElectraNet must provide inputs for the appropriate cells if it has calculated historical weather corrected maximum demand.*

(a) ElectraNet must describe its weather correction process in the basis of preparation. ElectraNet must describe whether the weather corrected maximum demand figures provided are based on raw adjusted maximum demand or raw unadjusted maximum demand or another type of maximum demand figure.

(b) Where ElectraNet does not calculate weather corrected maximum demand it may estimate the historical weather corrected data or shade the cells black. For Regulatory Years 2015 and thereafter ElectraNet must provide weather corrected maximum demand in accordance with best regulatory practice weather correction methodologies.

8.14 *Tables requesting system coincident data are referring to the demand at that particular point on the network (connection point) at the time of system (or network) peak.*

(a) For example, table 5.4.1 requests information about the maximum demand on connection points at the time of system or network peak.

(b) Conversely, non coincident data is the maximum demand at a particular point on the network (which may not necessarily coincide with the time of system peak). For example, table 5.4.1 requests information about non-coincident maximum demand at connection points. In table 5.4.1, ElectraNet must provide information about the maximum demand at each connection point in each year, which may not correspond to demand at the time of system peak.

(c) If ElectraNet does not record and/or maintain spatial maximum demand coincident to the system maximum demand, ElectraNet must provide spatial maximum demand coincident to a higher network segment. ElectraNet must specify the higher network segment to which the lower network segment is coincident to in the basis of preparation. For example, if ElectraNet does not maintain maximum demand data for connection points coincident to the system maximum demand, ElectraNet may provide maximum demand data coincident to regional demand. In this example, ElectraNet would specify the relevant region in the basis of preparation.

Table 5-2: Definitions Specific to Regulatory Template 4.3 - Maximum Demand and Utilisation - Spatial

Term	Definition
Embedded generation	See 'embedded generator'.
Embedded generator	Has the meaning prescribed in the National Electricity Rules
Maximum demand	Has the meaning prescribed in the National Electricity Rules. Note: this RIN sets out the specific types of maximum demand information we require to perform our obligations under the NER. For the avoidance of doubt, maximum demand refers to 30 minute demand unless otherwise indicated.
MVA	Mega volt ampere
MW	Megawatt.
Network	Has the meaning prescribed in the National Electricity Rules
Network coincident maximum demand	The load on the network at the time during which the network was experiencing its maximum demand for the relevant regulatory year.
Non-coincident maximum demand	The load on the connection point, or other spatial level, at the time during which the relevant connection point, or spatial level, was experiencing its maximum demand for the relevant regulatory year.

Term	Definition
Non-scheduled generator	Has the meaning prescribed in the National Electricity Rules
Normal cyclic rating	The maximum peak loading based on a given daily load cycle that an asset or element of the network can supply each day of its life under normal conditions resulting in a normal rate of wear. ElectraNet must provide its definition(s) of 'normal conditions'
Power factor	The ratio of demand in MW to demand in MVA.
Probability of exceedance (PoE)	<p>Typically, actual maximum demand is standardised to either, or both, of 10 per cent and 50 per cent PoE levels.</p> <p>The 50 (10) PoE demand level is the level of maximum demand that, on average, would be exceeded in 50 per cent (10 per cent) of seasons. It can be thought of as the maximum demand that would be observed or exceeded once every two (ten) years on average.</p> <p>The key driver of variability in demand is usually weather. However this is not always the case and the concept of POE is not necessarily tied directly to weather.</p>
Raw data	Refers to demand without weather correction.
Raw adjusted maximum demand	<p>Raw unadjusted maximum demand that is adjusted to system normal conditions. ElectraNet must adjust to system normal conditions by accounting for (temporary) switching relevant to the network segment, and for temporary load changes from major customers (such as temporary closure of major industrial customers). ElectraNet must not adjust maximum demand data for (permanent) transfers, block loads or embedded generation.</p> <p>The term, 'raw', refers to demand data that has not undergone weather correction.</p>
Raw unadjusted maximum demand	<p>Actual maximum demand as measured by ElectraNet at the specified network segment. This must not include any adjustments for factors such as switching, temporary load changes from major customers, transfers, block loads or embedded generation.</p> <p>The term, 'raw', refers to demand data that has not undergone weather correction.</p>
Scheduled generator	Has the meaning prescribed in the National Electricity Rules
Semi-scheduled generator	Has the meaning prescribed in the National Electricity Rules
Summer peaking	Maximum demand experienced over the period 1 October to 31 March.

Term	Definition
Switching	Temporary changes in network configuration and restoration made by ElectraNet for operational reasons.
Transfers	Permanent (or indefinite) changes in network configuration made by ElectraNet usually to manage demand growth.
Weather correction	The removal of the impact of temperature fluctuations so as to derive a maximum demand measure corrected to a probability of exceedance (PoE), usually 50% PoE and/or 10% PoE.
Winter peaking	Maximum demand experienced over the period 1 April to 30 September.

5.4.2 Data source and methodology

Table 5.4.1 Non-Coincident & Coincident Maximum Demand

National Grid Metering (NGM) data on which the NEM financial settlement is based has been used. This has been previously Quality Controlled by the Metering Data Agent (meter reader) and by AEMO prior to use in NEM settlement. It is also checked weekly by ElectraNet’s internal processes for reasonableness of Transmission Loss Factor.

All data is sourced from NGM Data extracted from the ElectraNet Oracle database to an Excel spreadsheet pivot table where the Data Slicer is used to extract data by Financial Year. The extracted data is used to calculate the required RIN parameters via appropriate formulae, following Appendix E and Appendix F of the RIN in an Excel workbook.

This data source is identical to that used for the economic benchmarking RIN.

This methodology relies on the fact that ElectraNet has contract agreed maximum demands (AMD) at each load connection point defined in the Electricity Transmission Code (ETC).

The ETC classifies individual connection points and connection point groups. The former does not normally have an alternative source of transmission supply and is not normally meshed with other connection points via the underlying distribution network. The latter (grouped) connection points are made up of multiple transmission connection points which are interconnected via the underlying sub-transmission network operated by the DNSP. There are no abnormal conditions to be adjusted for connection point groups.

The transmission connection agreements specify material censures for exceeding these AMDs without prior approval. During low system demand times load may be moved from one connection point to another to facilitate works by the TNSP or DNSP without penalty. Such transfers do not generally occur at time of high system demand. A threshold level of 105% of AMD has been chosen as a threshold for abnormal conditions.

1. Connection Point Raw Adjusted MD Non-coincident Maximum MW (Adjusted NMW)

Individual connection point's raw unadjusted MD non-coincident maximum MW (Unadjusted NMW) was worked out by identifying the maximum MW demand of the connection point in the Financial Year.

Adjustment

If the connection point is not in a group identified in the ETC then:

Adjusted NMW = Unadjusted NMW if $\text{Unadjusted NMW} < 1.05 \times \text{Agreed Maximum Demand of the connection point}$

Otherwise

Adjusted NMW = the MW demand of the connection point in the Financial Year that is closest but less than $< 1.05 \times \text{Agreed Maximum Demand of the connection point}$

If the connection point is in a connection point group identified in the ETC then:

Work out the connection point group's coincident maximum MW demand by firstly summing all the half-hour MW demands of the connection points in the group over the Financial Year and then by identifying the maximum summation of that Financial Year. Note the time and date of the group's coincident MW maximum demand

Adjusted NMW = MW demand of the connection point at the time/date of the group's coincident maximum MW demand.

2. Connection Point Raw Adjusted MD Coincident Maximum MW

Individual connection point's raw unadjusted coincident maximum MW demand was worked out by identifying the connection point's MW demand at the time/date of Network Level maximum coincident MW demand in *Table 5.4.1*. This is also the connection point's raw adjusted coincident maximum MW demand. In other words, no adjustment is required based on the assumption that at system peak there is no abnormal switching. This is the best estimate.

3. Connection Point Raw Adjusted MD Non-coincident Maximum MVA

Individual connection point's unadjusted MD non-coincident maximum MVA demand was worked out by identifying the MVA demand of the connection point at the time/date of the connection point's adjusted non-coincident maximum MW demand. This is also the connection point's raw adjusted non-coincident maximum MVA demand according to Appendix E and Appendix F.

ElectraNet has been unable to identify a valid basis for identifying Connection Point Raw Adjusted MD Non-coincident Maximum MVA which are not coincident with the equivalent MW peak. ElectraNet is also unable to identify a system normal condition under which a connection point adjusted MVA peak would not be coincident with the equivalent MW peak. Hence the Connection Point Raw Adjusted MD Non-coincident Maximum MVA is that occurring at the Connection Point Raw Adjusted MD Non-coincident Maximum MW peak.

4. Connection Point Raw Adjusted MD Coincident Maximum MVA

Individual connection point's unadjusted MD coincident maximum MVA demand was worked out by identifying the MVA demand of the connection point at the time/date of Network Level maximum coincident MW demand in *Table 5.4.1*. This is also the connection point's raw adjusted non-coincident maximum MVA demand according to Appendix E and Appendix F.

5. Connection Point Date MD Occurred Non-coincident

Individual connection point's Date MD Occurred Non-coincident is the date associated with its raw adjusted MD non-coincident maximum MW identified in 1 above.

6. Connection Point Half Hour Time Period MD Occurred Non-coincident

Individual connection point's Half Hour Time Period MD Occurred Non-coincident is the half hour time associated with its raw adjusted MD non-coincident maximum MW identified in 1 above.

7. Connection Point Date MD Occurred Coincident

Individual connection point's Date MD Occurred Coincident is the date associated with the date of Network Level maximum coincident MW demand in *Table 5.4.1*.

8. Connection Point Half Hour Time Period MD Occurred Coincident

Individual connection point's Half Hour Time Period MD Occurred Coincident is the half hour time associated with the time of Network Level maximum coincident MW demand in *Table 4.2.1*.

9. Connection Point Peaking Season Non-coincident

Individual connection point's peaking season non-coincident is the season in which the Raw Adjusted MD Non-coincident Maximum MW was registered. The Time and Date of the Raw Adjusted MD Non-coincident Maximum MW were compared with the "Summer peaking" and "Winter peaking" definition to work out the peaking season.

10. Connection Point Peaking Season Coincident

Individual connection point's peaking season coincident is the season in which the Raw Adjusted MD Coincident Maximum MW was registered. The Time and Date of the Raw Adjusted MD Coincident Maximum MW were compared with the "Summer peaking" and "Winter peaking" definition to work out the peaking season. This is also the same as the peaking season of the Raw Network Level coincident maximum demand.

The required submission data have been derived for each year as described above in a Excel workbook. The data was imported via Excel formula in a spreadsheet the same as the AER Category Analysis data templates for transmission network service providers. The imported data were then copied and pasted in the AER Category Analysis data templates.

Crosschecks have been carried out to ensure internal integrity.

Methodology for corrected maximum demand is described below:

ElectraNet has not kept and maintained historical data for embedded generation downstream of connection points and has received this data from SA Power Networks.

Connection Point Rating

Data sources

- ElectraNet Ratings (Operational) database
- ElectraNet System Switching Diagrams (SSD's) for other party owned plant ratings

ElectraNet has provided connection point ratings for the regulatory year, for previous years these cells have been shaded black. This is because a change in connection point rating (normal cyclic rating) may occur based solely on a desktop analysis (as discussed in section 2.3 Augex in the definition of normal conditions). Additionally, this rating change may not be linked to any change in the physical asset hence it is harder to trace and for this reason ElectraNet are of the opinion that this would be unnecessarily burdensome to back calculate historical connection point ratings.

If the connection point is a substation, the rating is the Normal cyclic rating of the substation transformer/s. Where there is more than one transformer such as for a N-1 configuration the summation of the transformer normal cyclic ratings is given. For the case of a line where there is more than one line directly in parallel such as for a N-1 configuration, the summation of the line seasonal thermal ratings is given.

This represents the N capacity of a given connection point (i.e. with all transformers and lines in service). The reliability requirement for each connection point is stipulated independently by the Essential Services Commission of South Australia (ESCOSA), with some connection points requiring redundancy, some requiring only some redundancy, and some requiring no redundancy at all. This redundancy requirement can be found in the SA Electricity Transmission Code (ETC). ElectraNet does not consider that using the summation of the ratings gives a true and representative proxy of the connection point rating in a N-1 configuration.

ElectraNet's transformers do not have seasonal cyclic ratings hence the non-coincident and coincident ratings will be the same. If the connection point is a line then it will be the seasonal thermal rating (constrained by terminal equipment if applicable) occurring at that time.

In the case where another party owns the assets to which the ratings apply the rating is assumed to be either the highest nameplate of the customer transformer (preferred) or the rating of the next upstream (ElectraNet owned) constraining piece of plant.

Some connection points are configured as grouped connection points. Such connection points in any given group are located in geographically separate locations, but service a common (meshed) load area. In these cases and when the rating applies to plant not owned by ElectraNet (some of the Metro Western Suburbs) these cells have been shaded black. In these cases it is not meaningful to present the capacity of the individual connection points, because capacity is shared between the connection points. Similarly the loading on an individual connection point is a function of the location of other connection points in the group, the load magnitude and location spread throughout the

load region, and the topology and nature of the underlying distribution network. A powerflow study is therefore required to meaningfully compare the ability of the group's set of connection points to supply the given load area. ElectraNet does not consider it possible to provide these ratings for the above reasons for the past or into the future.

If there are project works that have resulted in the temporary de-rating of the connection point at the end of the given regulatory year, this is ignored and the full connection point rating has been provided.

Connection point rating is at the end of the given regulatory year (as at 30 June XX).

ElectraNet must run the network to the lowest long run cost hence, connection point augmentation once triggered are sufficient for increases in load over the longer term. For efficiencies in procurement, delivery and spares, ElectraNet has standard transformer sizes, step changes to the next size up effect the connection point utilisation.

Large direct connect customers – weather correction and embedded generation

For ElectraNet's direct connected customers (excluding the NSP SA Power Networks), National Grid Metering (NGM) data on which the NEM financial settlement is based has been used. This has been previously Quality Controlled by the Metering Data Agent (meter reader) and by AEMO prior to use in NEM settlement. It is also checked weekly by ElectraNet's internal processes.

ElectraNet has excluded non-coincident maximum demands for regulatory year 2016-17, from the 28 September 2016 until the 11 October 2016 when the market was suspended by AEMO in accordance with the Rules as stated in the AER's Electricity Report..

Connection points with ElectraNet's direct connect customers are:

Davenport 275 kV	Mannum - Adelaide #2 3.3 kV
Woomera 132 kV	Mannum - Adelaide #3 3.3 kV
Middleback 132 kV	Millbrook 3.3 kV
Middleback 33 kV	Murray Bridge - Hahndorf #1 11 kV
Roseworthy 11 kV	Murray Bridge - Hahndorf #2 11 kV
Morgan - Whyalla #1 3.3 kV	Murray Bridge - Hahndorf #3 11 kV
Morgan - Whyalla #2 3.3 kV	Back Callington 11 kV
Morgan - Whyalla #3 3.3 kV	Stony Point 11 kV
Morgan - Whyalla #4 3.3 kV	Leigh Creek Coalfield
Mannum - Adelaide #1 3.3 kV	Pimba
Torrens Island House Suppliers	

ElectraNet has not adjusted the demands of our large industrial customers for embedded generation for either coincident or non-coincident demand. ElectraNet is not required to perform these calculations until Regulatory year 2015.

ElectraNet does not weather correct the non-coincident demands of our large industrial customers as these loads are not weather dependant. ElectraNet has been provided with weather corrected 10% POE and 50% POE demands from SA Power Networks. SA Power Networks has provided this information at the meshed connection point level.

ElectraNet has estimated the coincident 10% and 50% POE for our direct connect industrial customers. This is discussed in the basis of estimation below.

SAPN connection points

Data source:

- data supplied by SA Power Networks
- ElectraNet's oracle NGM data

ElectraNet has been provided with weather corrected 10% POE and 50% POE demands from SA Power Networks. SA Power Networks has provided this information at the meshed connection point level.

Note that as this demand information has been provided by SAPN, it will not completely reconcile to network level demand in per the previous section of this report as demand information has come from different sources. ElectraNet propose that for the next reporting period, network demand and weather corrected demand data will be provided by the same SAPN source.

ElectraNet has split this data into connection points at the level of National Metering Identifiers (NMIs). The splitting of the meshed connection point data for the Raw MW, Raw MVA, 10% POE MW, 10% POE MVA, 50% POE and 50% POE MVA values according to the MW percentage share for each NMI had of the sum of the meshed connection points at the date and times SA Power Networks nominated for each meshed connection point coincident and non-coincident maximum demand.

The NMI's have then be aggregated to the level of Transmission Network Identifiers (TNIs) consistent with the level of resolution supplied in previous RINs.

5.4.3 Basis of estimation

ElectraNet does not weather correct the non-coincident demands of our large industrial customers as these loads are not weather dependant. The Weather Adjusted 10 %POE and Weather Adjusted 50% POE demands have been provided by SA Power Networks. ElectraNet has been provided with weather corrected 10% POE and 50% POE demands from SA Power Networks. SA Power Networks has provided this information at the meshed connection point level.

Embedded generation has been estimated based on available SCADA values of major embedded generators and ElectraNet's estimation of solar output across the state. Actual solar PV installations at each connection point as at August 2015 was supplied by SA Power Networks. The capacity is further scaled down according to the state-wide level of installations reported by the Clean Energy Regulator for the month the maximum occurred at each connection point.

ElectraNet has accounted for the diversity of our direct connect customers with the time of state-wide peak demand.

ElectraNet has estimated the coincident weather adjusted 10% POE and weather adjusted 50% POE values based on the relationship between the observed annual maximum non-

coincident demands and the coincident (state-wide) maximum demand over the last 12 years. For each year, the coincident maximum was divided by the non-coincident maximum. This value is then a percentage of the non-coincident maximum that was observed that at time of the coincident (state-wide) maximum.

With the 12 years of history, the 90th and 50th percentile values have been used to determine the 10 and 50% POE multipliers, to be applied to the non-coincident maximum and this has determined the Weather Adjusted 10% POE and the weather adjusted 50% POE.

The Dry Creek Exit connection point is a member of the meshed Eastern Suburbs connection point and is usually zero. ElectraNet have not applied a weather correction or for this connection point as the basis for the supplied 10% and 50% POE numbers for the Eastern Suburbs is not an appropriate basis on which to determine this individual connection point.

The Dry Creek connection point is usually zero. Under certain network reconfiguration's the connection point may see demands reach around 100 MW. These conditions are unrelated to weather. As such weather corrected values are not relevant. The connection point is part of the meshed Eastern Suburbs connection point, for which 10% and 50% weather corrected values fully account for this connection point. Hence the maximum non-coincident value has been recorded, weather corrected values are not estimated.

5.4.4 Changes to accounting policies

N/A – Information reported within 5.4 of the data template is not impacted by any accounting changes during the reporting period.



Basis of Preparation

AER Category Analysis RIN

Appendices

October 2017

DRAFT

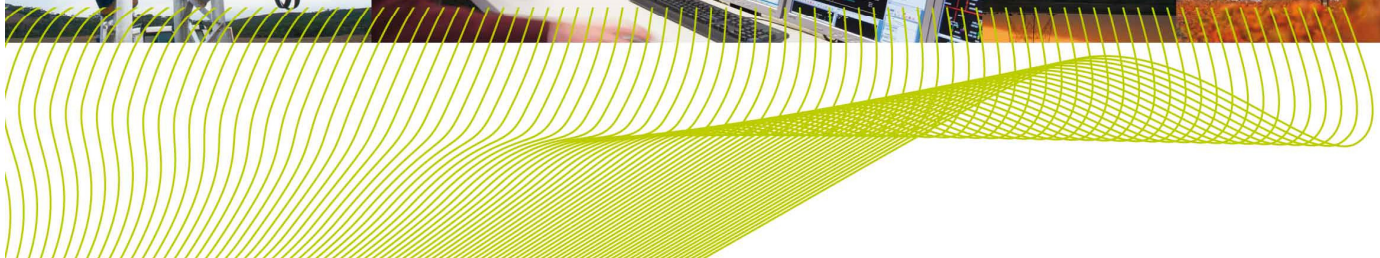

Appendix A ElectraNet Vegetation Management Zones

A1 Total network area with borders for each vegetation management zone

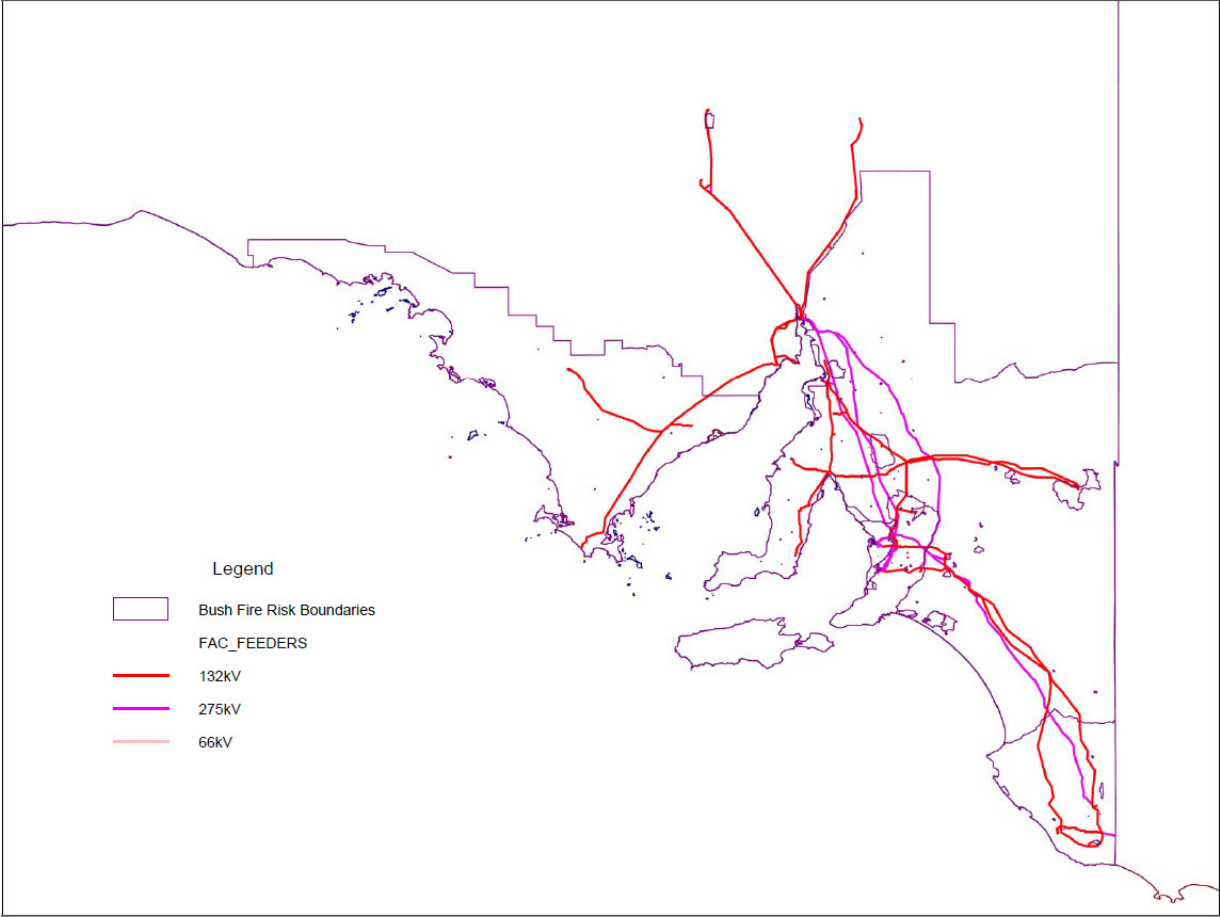

A1.1 High Bushfire risk zones

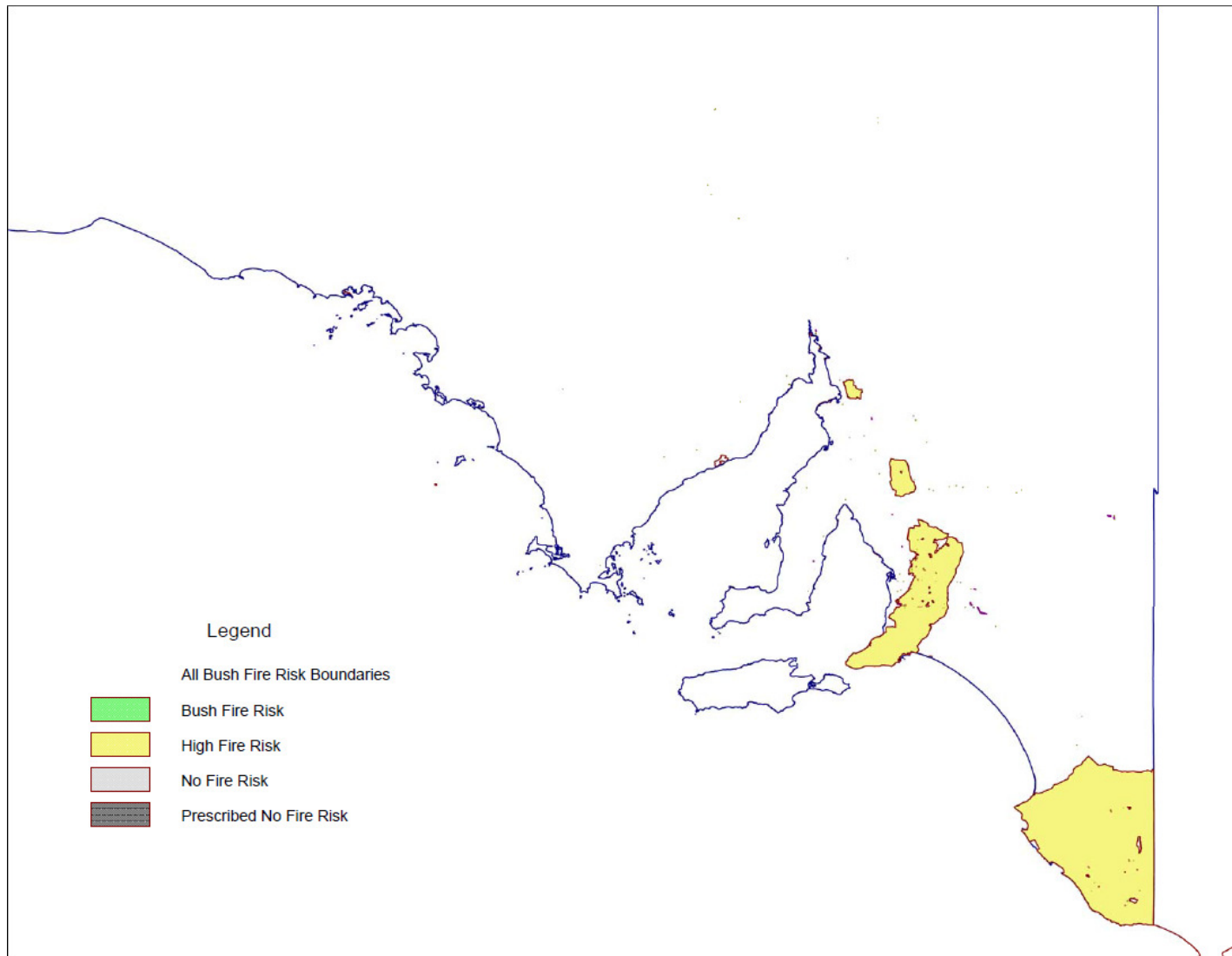

A1.2 Bushfire risk zones

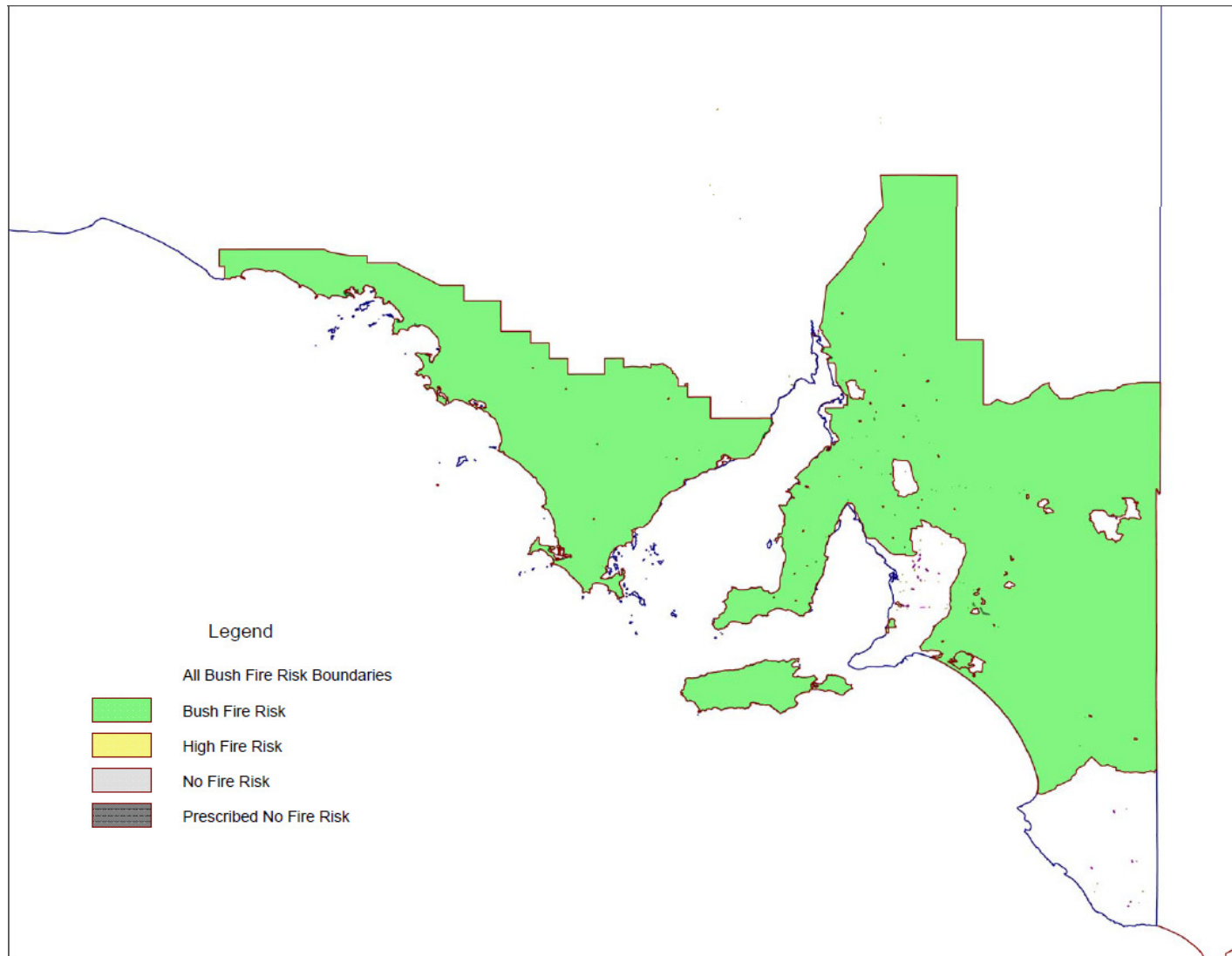

A1.3 Non-bushfire risk zones

