

# CUSTOMER ELECTRIFICATION FORECASTING METHODOLOGY

UE ATT 2.01 – PUBLIC  
2026–31 REGULATORY PROPOSAL

# Table of contents

<b>1. A new approach to support customers</b>	<b>3</b>
<b>2. Time-series forecasting</b>	<b>4</b>
2.1 Demand forecast	5
2.2 CER load profiles	5
<b>3. Evolving power-flow simulations</b>	<b>12</b>
3.1 Zepben executive summary	12
<b>4. Power-flow output tag mapping and definitions</b>	<b>14</b>
4.1 Model topology	21
<b>5. Our modelling expands beyond power-flow analysis</b>	<b>22</b>
5.1 Data consolidation	22
5.2 AWS sequence part 1	22
5.3 AWS sequence part 2	23
5.4 Post proactive modelling	23
5.5 Supporting modelling	24
<b>6. Data quality checks</b>	<b>25</b>
6.1 Filters	25
6.2 Filling the gaps	25
6.3 Forecast forward	26
<b>7. Summating energy at risk values</b>	<b>27</b>
7.1 Valuing undervoltage load	27
7.2 Valuing customer overvoltage export curtailment	29
<b>8. Calculating voltage alleviations</b>	<b>31</b>
8.1 Reconductoring augmentation	31
8.2 DSS offload augmentation	33
8.3 BESS augmentation	35
<b>9. Evaluate all economic augmentations</b>	<b>38</b>
9.1 Formulae	39

9.2	Assumptions	40
<b>10.</b>	<b>Forecasting voltage compliance</b>	<b>41</b>
10.1	Undervoltage Equations	41
10.2	Undervoltage compliance forecasting	44
10.3	Overvoltage compliance forecasting	46
<b>11.</b>	<b>Modelling augmentations in weekly voltage compliance</b>	<b>48</b>
11.1	Fomulae	48
11.2	Methodology	48
<b>12.</b>	<b>Generate service level results</b>	<b>51</b>
12.1	Methodology for site selection	51
<b>13.</b>	<b>Predicting complaints from compliance</b>	<b>54</b>
13.1	Estimating reactive projects from weekly complaints:	55
<b>14.</b>	<b>HV cluster efficiency</b>	<b>59</b>
<b>15.</b>	<b>Calculating flexible exports</b>	<b>63</b>
<b>16.</b>	<b>Voltage compliance POE 10 forecast</b>	<b>66</b>
16.1	Logic for detecting compliance peaks by season	66
16.2	Logic for modelling the effect of POE10 versus POE50	66
<b>17.</b>	<b>Regional and rural equity – SWER upgrades</b>	<b>68</b>
17.1	Risk calculation	68
17.2	Cost of upgrades	68
17.3	All economic upgrades	69

# 1. A new approach to support customers

Traditionally, our electrical modelling approaches have relied on taxonomic representations of network topologies and point-in-time power flow simulations that approximate the expected performance of the network. Economic assessments have typically interpolated or synthetically represented customers as homogeneous units to derive potential economic outcomes and determine network-level investment requirements.

While these methods were considered best practice for their time, they fall short in addressing the increasingly dynamic interplay between energy import and export, as well as the diversity in network topologies, customer demographics, and consumption behaviours across our expansive networks. Additionally, the evolving dynamics of price and demand now necessitate constraint assessments that can accurately analyse intraday demand patterns, export behaviours, and economic values.

Recognising these limitations, we have developed a next-generation modelling approach that faithfully reflects both our network topology and customer behaviours. Our model captures the full extent of the network, starting at the zone substation bus and extending all the way through the high voltage network to individual customer connection points within the low-voltage network.

Key improvements on traditional approaches include:

- utilisation of actual and comprehensive customer AMI Data: Power flow simulations leverage actual Advanced Metering Infrastructure (AMI) data tied to customers' specific points of supply, enabling us to simulate power flows every 30 minutes. This ensures that dynamic behaviours and diversities in consumption and export are accurately represented in the results
- granular network representation: The model integrates detailed and complete network topology, allowing for a comprehensive and realistic assessment of constraints and performance
- advanced data management and cloud computing: The massive datasets generated by this approach require advanced data management capabilities. Our economic assessments are now fully scripted and executed via cloud computing platforms, enabling efficient processing of large-scale simulations and analyses.

This step-change advancement is essential for providing robust, data-driven planning advice on how our network must evolve to meet the changing requirements and expectations of our customers. By embracing this innovative approach, we ensure greater accuracy, reliability, and confidence in our network investment decisions, ultimately delivering better outcomes for both customers and stakeholders.

This methodology aims to provide a conceptual overview of the approach developed and executed within our scripts. Figure 1 summarises the evolution in our modelling.

**FIGURE 1** EVOLUTION FROM POINT TO TIME SERIES MODELLING

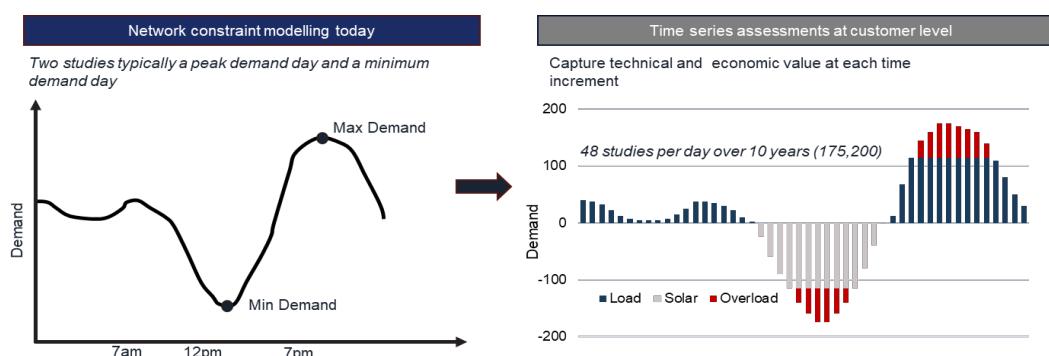

## 2. Time-series forecasting

Accurately estimating future network performance requires understanding how shifts in energy demand will affect the network. Key drivers of future energy demand include population changes, weather patterns, and the adoption of customer energy resources (CER) such as photovoltaic (PV) systems, electric vehicles (EVs), energy storage, electrification trends, and large-scale generation or block loads. Therefore, confident network performance forecasting depends on reliable projections of these factors.

To address this, the probabilistic demand forecasting task was outsourced to Blunomy, whose model is forecasting the demand as a 30-minute time-series over forecast horizon of 25 years. The forecast is modelled across representative set of weather conditions and employs an ensemble of specialised modules. Each module forecasts distinct components, including Native Demand, CER Adoption (PV, EV, and Storage), Electrification of Gas Consumption, Large Generators, and Block Loads.

Every model in the ensemble combines specialised short-term time series forecast and long-term Socioeconomic forecast. The short-term models focus on granular patterns, leveraging machine learning and scientific simulations to capture correlations from data sources such as AMI meter readings and weather conditions. **Long-term models** rely on (AEMO) forecasts, demographic trends, and historical data to project broader trends in energy demand and CER uptake.

Forecasting the complete demand time-series (as opposed to only forecasting the peak demand) allows the model to consider the structural changes in the load patterns and the impact of new technologies on maximum and minimum demand. The time-series forecast methodology is divided into two key sections, Demand Forecast and CER Load Profiles that are key inputs to our CER and Electrification modelling approach.

Figure 3 demonstrates a time-series forecast.

**FIGURE 2 TIME-SERIES FORECAST AS A PRODUCT OF SHORT-TERM FORECAST AND LONG-TERM TREND**

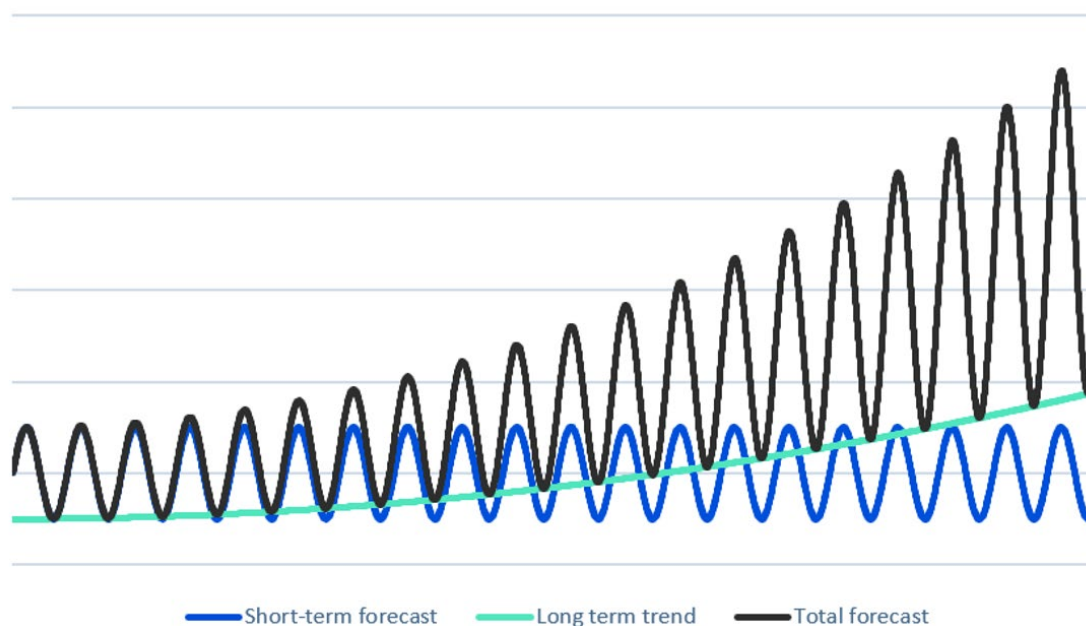

## 2.1 Demand forecast

A comprehensive technical guide detailing the demand forecast methodology can be found in Demand Forecasting supporting document.

## 2.2 CER load profiles

CER Load Profiles are essential in time-series forecast and time-series network modelling. The individual technology demand profiles can be combined with customer's historical demand profile to precisely model the uptake of CER at individual customer level.

Solar PV generation, battery energy storage charge/discharge and EV charging profiles are modelled based on available data and feed into Zepben's power flow model, described in Section 4 .

Each demand profile is based on possible customer behaviour. Each modelled profile is coupled with a weighting that determines the probability and distribution of these behaviours in the forecast.

### 2.2.1 Solar PV generation

To enhance our model's accuracy, we received PV generation data from Blunomy estimating the solar PV generation for each PV customer and aggregated at the feeder level to identify geographical based generation trace, aligned to our forecasting methodology. These profiles are 30min historical time-series generation (kW) per 1 kW of installed PV for the period of 1st of April 2020 to 31st of March 2024. Figure 5 illustrates a sample set of historical solar PV generation.

**FIGURE 3 SOLAR PV AND BATTERY STORAGE PROFILES OVERVIEW**

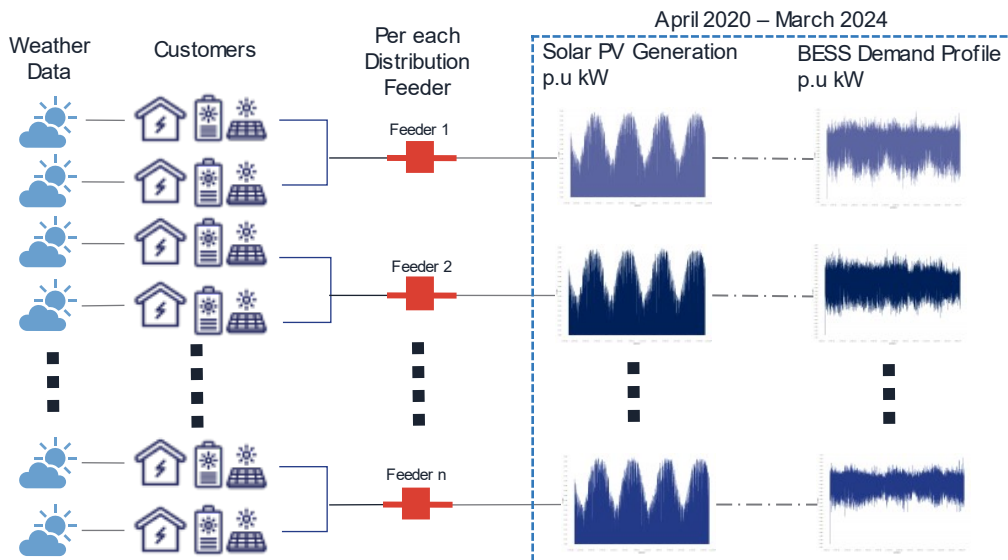
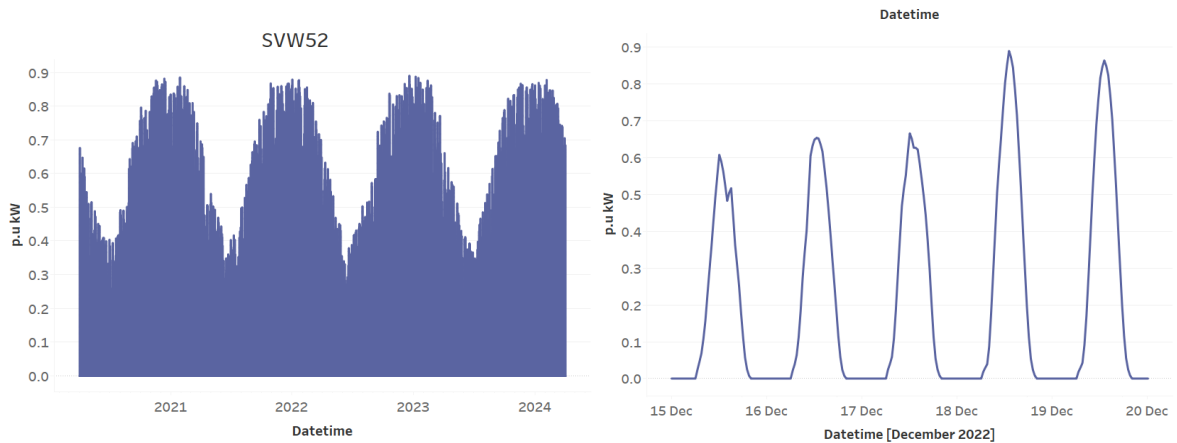

Figure 5 show an example of solar generation profile.

**FIGURE 4 HISTORICAL SOLAR GENERATION FOR A FEEDER**



### Distribution

As part of the input to Zepben’s Hosting Capacity Module (HCM), a distribution of solar systems was provided. This avoids applying a one-size-fits-all assumption to the forecast, instead offering a pool of diverse system types that can be allocated to different customers. The percentage share of each system size was calculated using the previous 2 years of installation data per distribution feeder. Table 1 below summarises modelled system sizes and their distribution the network.

**TABLE 1 SOLAR PV SYSTEM SIZE AND DISTRIBUTION**

SYSTEM SIZE	CONNECTION TYPE	DISTRIBUTION (BASED ON LAST 2 YEARS)
5 kW	1-phase	85% at network level
10 kW	3-phase	10.5% at network level
10 kW	1-phase	4.5% at network level

### 2.2.2 Battery energy storage charge/discharge

Similarly to the solar PV demand profiles, battery energy storage charge/discharge profiles are provided by Blunomy for each distribution feeder. These profiles are 30min historical charging demand (kW) per 1 kWh of charging capacity for the period of 1 April 2020 to 31 March 2024. Figure 6 below shows a sample of this data set.

**FIGURE 5 HISTORICAL BESS & PV TRACE FOR A FEEDER**

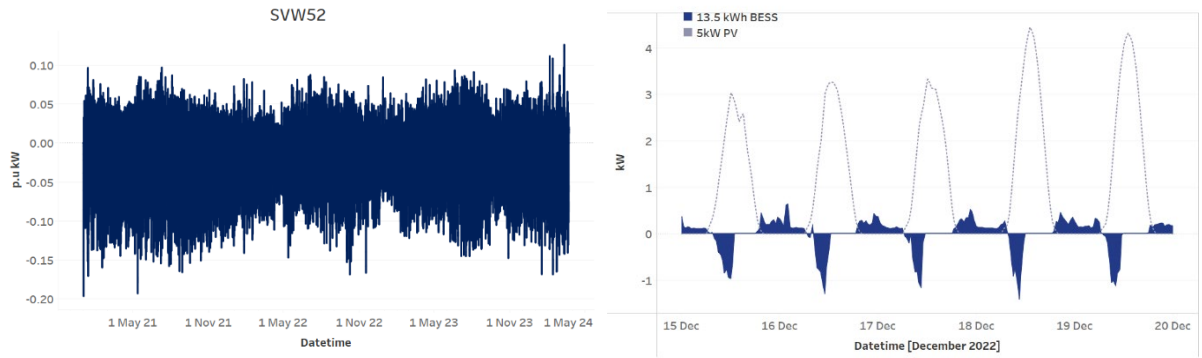

**Distribution**

It is assumed that all the residential battery storage systems will be coupled with a solar PV system and the size of BESS units is 13.5 kWh (similar to Tesla Powerwall), shown at table 2.

**TABLE 2 RESIDENTIAL BESS AND PV SIZE**

BESS SYSTEM SIZE	PV SYSTEM SIZE	DISTRIBUTION
13.5 kWh	5 kW	Same PV distribution
13.5 kWh	10 kW	Same PV distribution



### 2.2.3 EV charging

Electric Vehicles are one of the fastest growing consumer energy resources (CER) and it is expected to have a big impact in our network. However, there is a big limitation in availability of data around EV charging demand. It is very important for our business to understand how customers might charge their EV, how much additional power is used in each charging events, when and where those charging events occur.

There has been a few external studies and research around EV charging profiles which is all based on sample of EVs or customer surveys. Internally we have identified a key gap in this area and lack of studies with a focus of customer behaviours in Victoria. As a result, we have built an EV detection and segmentation machine learning model to detect customer with EVs and Level 2 charging using customer's AMI meter data.

The detection model is not just detecting the presence of an EV but creating a dataset of customer's AMI data where charging events are flagged. A sample of these flagged charging signals are what is used as EV charging demand profiles as an input to HCM model. A detailed technical report outlining the EV detection and segmentation methodology is available upon request.

Figure 7 below is an illustration of our internal EV detection model.

**FIGURE 6 EV DETECTION AND PROFILE MODEL OVERVIEW**

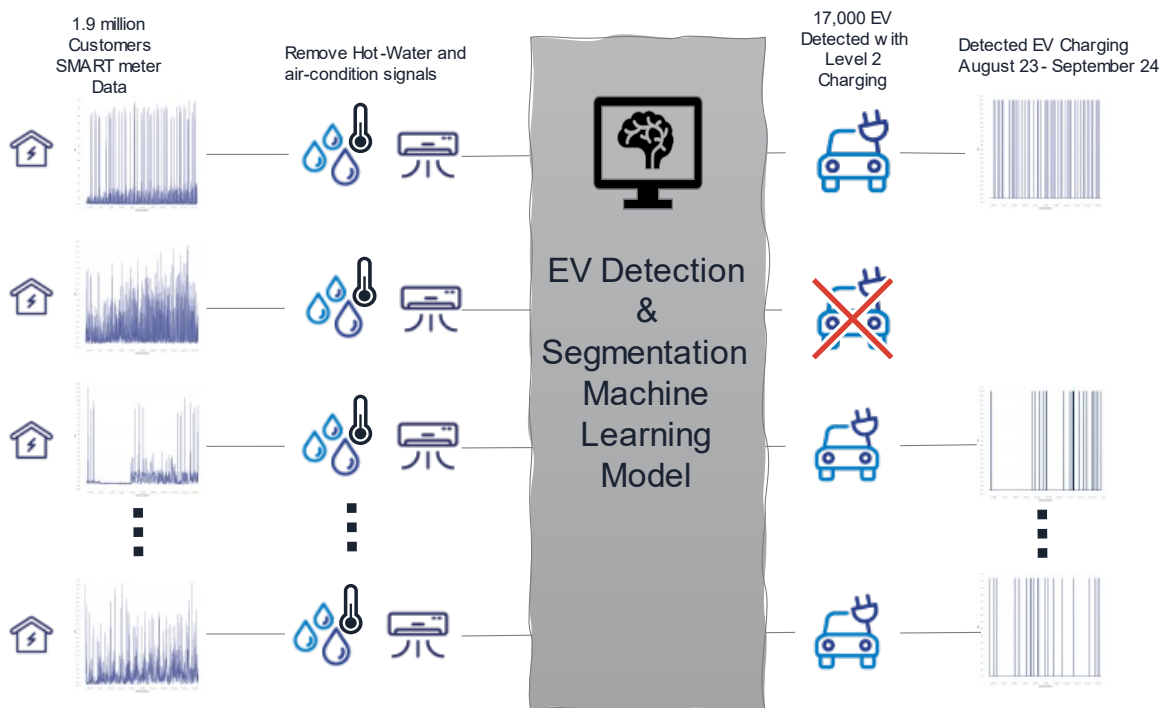
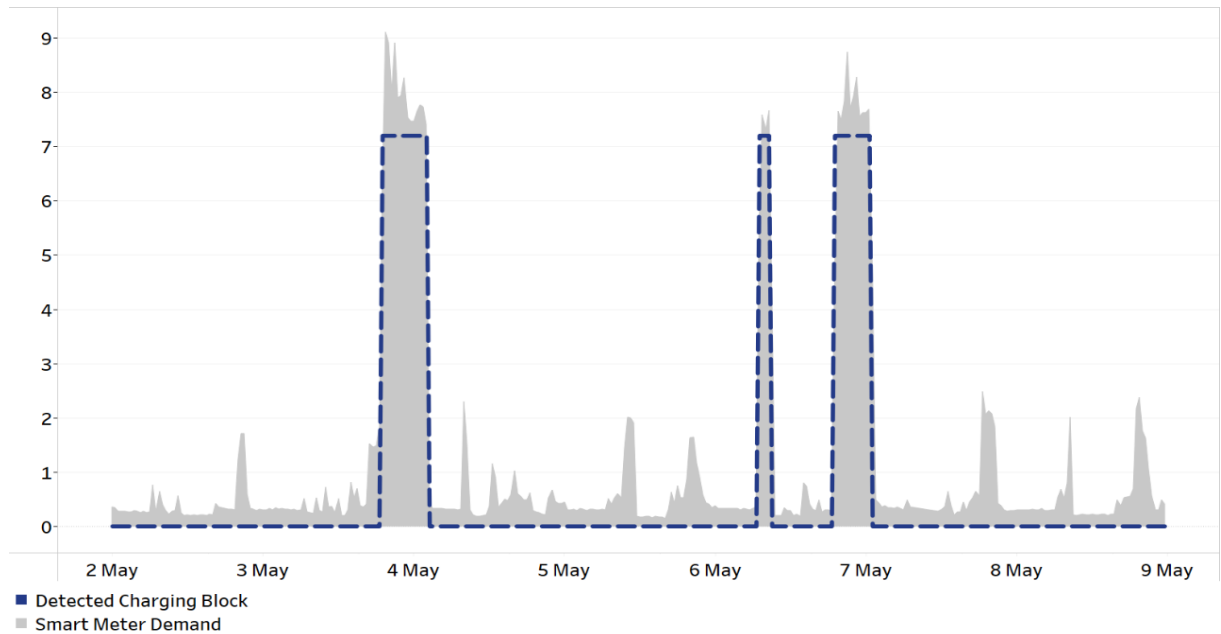

Figure 8 shows an example of detected EV charging signals from customer load.

**FIGURE 7 EXAMPLE OF DETECTED EV CHARGING FROM A SMART METER DATA (KW)**



**Demand profiles**

Leveraging from our internal EV detection studies, a sample of detected EV customers across all three network was selected. The sample includes one year of smart meter data where the EV charging event was detected. Figure 9 below shows a few of these charging signals.

**FIGURE 8 EV CHARGING EVENTS – SAMPLE (KW)**

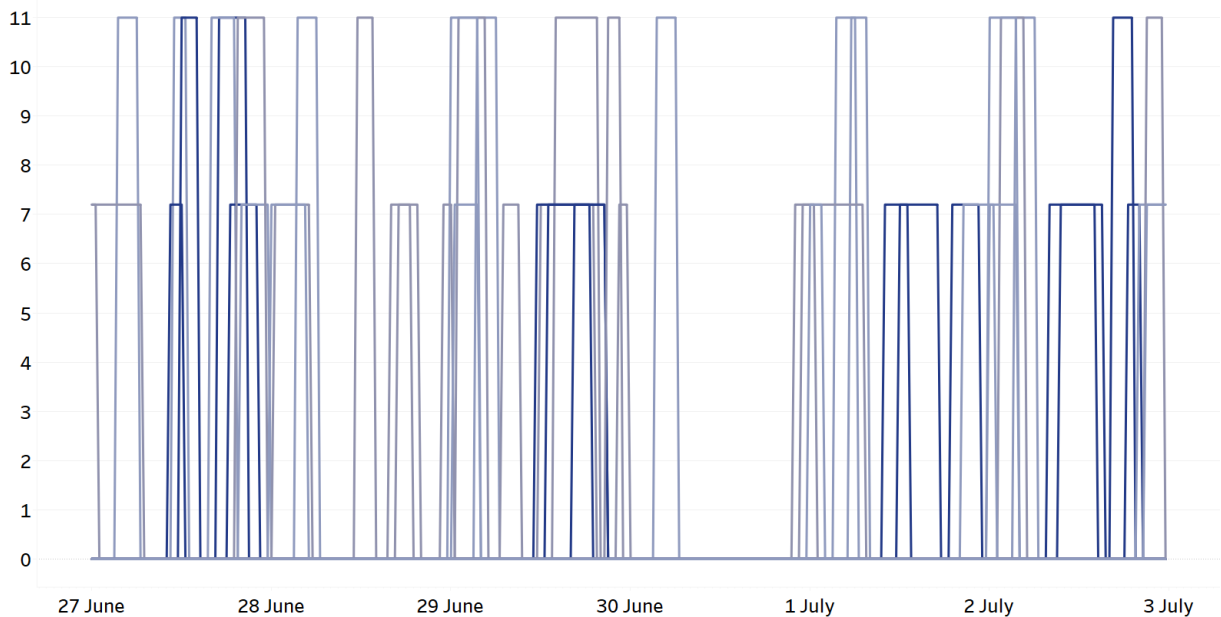

These charging signals are raw output of the model and may include noise associated with customer load additional to EV charging. To remove this noise, we have first mapped each charging signal to a maximum charging power of:

- 7.2kW – Level 2 on single phase connection

- 11kW – Level 2 on three phase connection
- 22kW – Level 2 on three phase connection with a fast charger.

This will give us an accurate sample of EV charging profiles for customers with level 2 chargers. Next, we have used these profiles to model EV customers with trickle charging (level 1).

Trickle charging profiles was modelled by using the detected level 2 charging events and normalising the profile, so the maximum charging power does not exceed 2.4kW. Next, the number of charging events was extended so the same amount of energy is used for charging an EV.

### Distribution

The final set of demand profiles are representing 4 different levels of charging power and 4 different charging behaviour. Each of these profiles receives a weighting from 0-100% into the forecast years.

### Charging power

A split of 30/70% between Level 1 and Level 2 chargers was assumed supported by Future Home Demand report by Monash University<sup>1</sup>. Using solar customers as a proxy, there will be 85% single phase and 15% three phase chargers for Level 2 charging customers. Table 3 below shows this breakdown and distribution of each charging power.

**TABLE 3 CHARGING POWER DISTRIBUTION**

CHARGING POWER	CONNECTION TYPE	DISTRIBUTION
2.4kW	1-phase	30%
7.2kW	1-phase	59.5%
11kW	3-phase	9.975%
22kW	3-phase	0.525%

### Charging behaviour

The internal EV detection model is also segmenting the customers based on their charging behaviour. These charging behaviour segments are:

- Convenience
- Light Convenience
- Night Owl
- Day Charging

AEMO's 2024 IASR is forecasted that the share of convenience charging is expected to decline over years and this trend is applied to our distribution of charging behaviour over time. This change in charging behaviour is shown in Figure 10.

<sup>1</sup> UE ATT SE.10 – Monash University - Future home demand – Jul2023 – Public

**FIGURE 9 CHARGING BEHAVIOUR DISTRIBUTION FORECAST (%)**

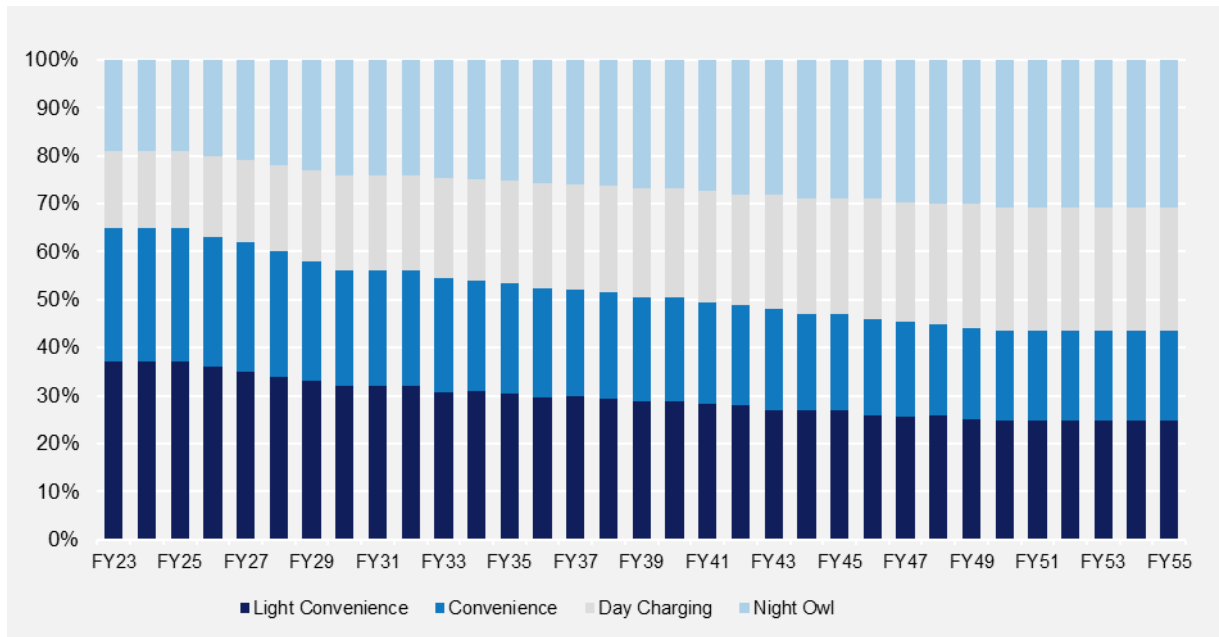

### 3. Evolving power-flow simulations

We have engaged Zepben to develop a comprehensive high-voltage (HV) to low-voltage (LV) simulation of our network through their Energy Work Bench (EWB) platform. Through this collaboration, we have evolved Zepben’s power flow methodology, enabling us to harness Victorian customers’ investment in Advanced Metering Infrastructure (AMI) and meet Victorian power quality commitments.

A detailed write-up of the Zepben methodology is provided in the document below.

The executive summary of this document is included as section 4.1, highlighting key enhancements to the power flow methodology.

**FIGURE 10 POWER FLOW METHODOLOGY**

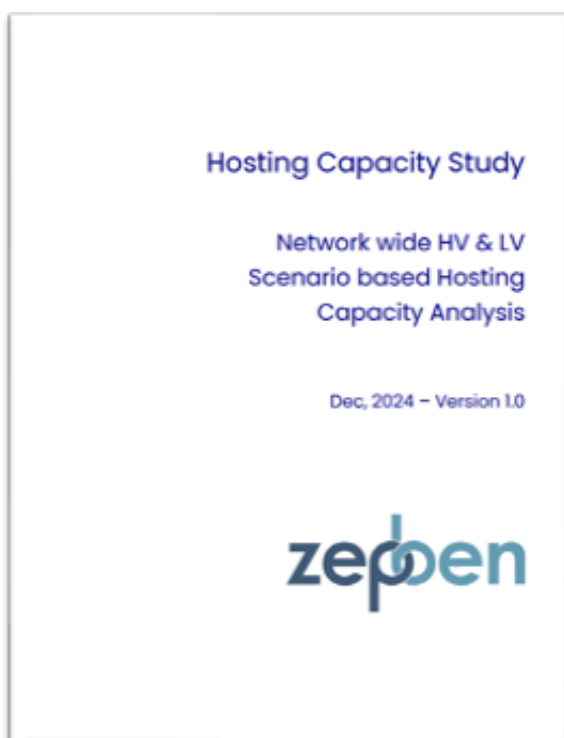

#### 3.1 Zepben executive summary

Zepben has delivered a significant evolution in customer electrification modelling to CitiPower, Powercor, and United Energy. For the first time, near-complete AMI power quality data has been utilised in a comprehensive high-voltage (HV) to low-voltage (LV) power flow simulation, spanning from the zone substation bus to individual customer connection points. This model represents unprecedented capability, ensuring the customer electrification transition is technically informed and managed with confidence.

Key highlights of this evolution are in the sub-sections below.

##### 3.1.1 Unmatched power flow accuracy:

By utilising extensive AMI power quality data for each customer connection, along with detailed equipment control settings, the model has been able to determine unknown off load tap changer positions, removing a key uncertainty from the model that has impacted previous work in this space.

This enables the model to achieve an accuracy of  $\pm 2\%$  for 90% of customer connection points, making it the most precise and reliable model Zepben has developed to date.

### **3.1.2 Comprehensive network coverage:**

The model used is a complete electrical 'digital twin' of the CitiPower, Powercor, and United Energy networks. Representing the 110,000 kms of HV and LV 'poles and wires' used in the delivery energy to the nearly two million customer network connection points.

The model executed hundreds of billions of power flow calculations, producing time-series results for nearly two million customer connection points at 30-minute intervals spanning a decade (2024–2034). Each time series is aligned to actual network observations and tailored forecasts for specific customer segmentation.

### **3.1.3 Industry validation:**

The Hosting Capacity Module developed and used by Zepben has had its approach to power flow modelling previously validated by the University of Melbourne, affirming the robustness, reliability of the approach.

### **3.1.4 Enhanced analytical capabilities:**

Zepben collaborated with CitiPower, Powercor, and United Energy to enhance Zepben's modelling capabilities. The primary focus was on deploying analytics to raw timeseries power flow results to facilitate detailed economic modelling of compliance, curtailment, and energy at risk.

This collaboration led to the integration of voltage compliance analysis, identification of power quality improvement opportunities, and detailed valuation of curtailment by applying 30-minute timeseries forecasts for CECV. These advancements facilitated precise curtailment valuation and forecasting of power quality performance at individual customer supply points, ensuring alignment with Victorian Voltage Compliance obligations and supporting proactive network management strategies.

### **3.1.5 Confidence in future decisions:**

The simulation results provided detailed performance insights, achieving comprehensive network coverage for each of the three networks, enabling effective decision-making and future planning.

This advanced model represents the most detailed and accurate simulation framework developed to date, providing unparalleled insights into current and future power quality performance and network reliability. The collaboration between CitiPower, Powercor, and United Energy, supported by cutting-edge technology and academic validation, sets a new industry benchmark for precision, scalability, and actionable intelligence.

## 4. Power-flow output tag mapping and definitions

This section provides an overview of the outputs from the power flow modelling conducted by Zepben, as outlined in Section 4. The tables in this section provide an overview of the elements used to develop our coded approach, which is outlined section 6.

There are two distinct metrics used to build our approach:

- Network performance metrics provide a yearly aggregate of the 30-minute power flow results by site.
- Weekly report in contrast is an aggregate of sites and timesteps by week

Table 4 through to Table 10 below contain the tags used in our modelling.

**TABLE 4 NETWORK PERFORMANCE METRICS TAGS**

TAG	DESCRIPTION	FORMULA
feeder	The feeder for this input	The feeder for this input
mz_type	The type of asset class that forms the 'head' of the measurement zone	-
conducting_equipment_mrid	This is a unique identifier for the asset that forms the 'head' of the measurement zone	-
season	as per config - e.g. {spring, summer, autumn, winter, annual}	-
time_of_day	as per config - e.g. {day, solar_day, night, all}	-
v_base	voltage base of metrics - expressed in ph-ph voltage.  For Transformers voltage base is reported as the secondary voltage  This field should be used to convert from per unit results into magnitudes	switch = first phv.vbase, tx = first lv phv.vbase
maximum_section_voltage	Maximum recorded voltage for a measurement_zone. This is the max voltage recorded across all the nodes and all phases within the measurement_zone. Note that the relevant time period is defined by the timestamp, season and time_of_day.	Max(Max(phv.phs1.max, phv.phs2.max, phv.phs3.max))

**TABLE 5 NETWORK PERFORMANCE METRICS TAGS CONTINUED**

<b>TAG</b>	<b>DESCRIPTION</b>	<b>FORMULA</b>
minimum_section_voltage	Minimum recorded voltage for a measurement_zone. This is the min voltage recorded across all the nodes and all phases within the measurement_zone. Note that the relevant time period is defined by the timestamp, season and time_of_day.	Min(Min(phv.phs1.min, phv.phs2.min, phv.phs3.min))
voltage_delta_max	The maximum voltage phase delta detected.  Here the delta in voltage between nodes in a measurement_zone is calculated for each phase and each timestep. The maximum of this delta is then taken to show the worst case voltage difference between nodes on the measurement_zone.	Max(Max(phv.phs1.max - phv.phs1.min, phv.phs2.max - phv.phs2.min, phv.phs3.max - phv.phs3.min))
load_kwh	The sum of all energy consumed by elements modelled as loads (underlying demand, net BESS and EVs), within the measurement_zone during the relevant time period.	sum(di.zoneKwh)
load_undervoltage_normal_kwh	This metric calculates the scaled sum of kWh. Scaling is performed per Energy scaling is used to capture only a proportion of the circuit energy as at risk, depending on the magnitude of undervoltage.	Sum((lowScaling) * di.zonekWh)  where phv.phs.avg < VH1
generation_kwh	Total generation over the measurement_zone.  Where base year generation is defined by the AMI data export channels or equivalent data, and forecast generation is directly added to the model and so captured as gross generation connected.	sum(di.genKwh)



**TABLE 6 NETWORK PERFORMANCE METRICS TAGS CONTINUED**

<b>TAG</b>	<b>DESCRIPTION</b>	<b>FORMULA</b>
gen_overnoltage_kwh	<p>The sum of energy generated by PV systems whilst overvoltage event is recorded.</p> <p>Scaling is performed as per figure 24. to include include partial generation energy from 253V, and not include the full amount of measurement_zone energy until the average measurement_zone voltages reach 260V.</p>	<p>Sum(highScaling * di.genKwh) where phv.phs.avg voltage &gt; VH1</p>
gen_overnoltage_cecv	<p>This metric is the same as gen_overnoltage_kwh defined above, multiplied by the relevant Customer Export Curtailment Value (CECV) for each interval the overvoltage is present. Scaling is included to include partial generation energy from VH1 (default 253v for 230v base), and not include the full amount of measurement_zone energy until the average measurement_zone voltages reach VH2 (default 260v for 230v base)</p>	
gen_overnoltage_co2	<p>This metric is the same as gen_overnoltage_kwh defined above, multiplied by the relevant the timeseries value of CO2 for each interval the overvoltage is present. Scaling is included to include partial generation energy from VH1 (default 253v for 230v base), and not include the full amount of measurement_zone energy until the average measurement_zone voltages reach VH2 (default 260v for 230v base)</p>	

**TABLE 7 WEEKLY REPORT TAGS**

<b>COLUMN NAME</b>	<b>DESCRIPTION</b>	<b>FORMULA</b>
timestamp	Expressed in UTC	
feeder	The feeder for this input	
mz_type	The type of asset class that forms the 'head' of the measurement zone	
conducting_equipment_mrid	This is a unique identifier for the asset that forms the 'head' of the measurement zone	
v_base	<p>voltage base of metrics - expressed in ph-ph voltage.</p> <p>For Transformers voltage base is reported as the secondary voltage</p> <p>This field should be used to convert from per unit results into magnitudes</p>	<p>switch = first phv.vbase, tx = first lv phv.vbase</p>
v99_avg	<p>This boolean value is true if the 99th percentile for the average node and phase voltage over the relevant time period is greater than VH1 (default 253v)</p> <p>Reporting runs from Sunday to Saturday, starting the first Sunday of the modelling year. This aligns with VIC ESC reporting guidelines.</p>	<p>true if 99th percentile sample of sorted Avg(Phs_1.avg, Phs_2.avg, Phs_3.avg) is &gt; VH1, otherwise false/null</p>
v99_max	<p>This boolean value is true if the 99th percentile for the average node and maximum phase voltage over the relevant time period is greater than VH1 (default 253v)</p> <p>Reporting runs from Sunday to Saturday, starting the first Sunday of the modelling year. This aligns with VIC ESC reporting guidelines.</p>	<p>true if 99th percentile sample of sorted Avg(Phs_1.max, Phs_2.max, Phs_3.max) is &gt; VH1, otherwise false/null</p>

**TABLE 8 WEEKLY REPORT TAGS CONTINUED**

<b>COLUMN NAME</b>	<b>DESCRIPTION</b>	<b>FORMULA</b>
v1_avg	<p>This boolean value is true if the 1st percentile for the average node and phase voltage over the relevant time period is below than VL1 (default 216v)</p> <p>Reporting runs from Sunday to Saturday, starting the first Sunday of the modelling year. This aligns with VIC ESC reporting guidelines.</p>	<p>true if 1st percentile sample of sorted Avg(Phs_1.avg, Phs_2.avg, Phs_3.avg) is &lt; VL1, otherwise false/null</p>
v1_min	<p>This boolean value is true if the 1st percentile for the average node and minimum phase voltage over the relevant time period is below than VL1 (default 216v).</p> <p>Reporting runs from Sunday to Saturday, starting the first Sunday of the modelling year. This aligns with VIC ESC reporting guidelines.</p>	<p>true if 1st percentile sample of sorted Avg(Phs_1.min, Phs_2.min, Phs_3.min) is &lt; VL1, otherwise false/null</p>
v99_avg_value	<p>The 99th percentile for the average node and phase voltage over the relevant time period.</p>	<p>99th percentile sample of sorted Avg(Phs_1.avg, Phs_2.avg, Phs_3.avg)</p>
v99_max_value	<p>The 99th percentile for the average node and maximum phase voltage over the relevant time period.</p>	<p>99th percentile sample of sorted Avg(Phs_1.max, Phs_2.max, Phs_3.max)</p>
v1_avg_value	<p>The 1st percentile for the average node and phase voltage over the relevant time period.</p>	<p>1st percentile sample of sorted Avg(Phs_1.avg, Phs_2.avg, Phs_3.avg)</p>
v1_min_value	<p>The 1st percentile for the average node and minimum phase voltage over the relevant time period.</p>	<p>1st percentile sample of sorted Avg(Phs_1.min, Phs_2.min, Phs_3.min)</p>

**TABLE 9 WEEKLY REPORT TAGS CONTINUED**

<b>COLUMN NAME</b>	<b>DESCRIPTION</b>	<b>FORMULA</b>
load_kwh	<p>The sum of all energy consumed by elements modelled as loads (underlying demand, net BESS and EVs), within the measurement zone during the relevant time period.</p> <p>Note this does not include energy that is supplied via the measurement zone, or network losses, it is only energy delivered to consumers within the measurement zone. This allows aggregation of measurement zone results, as delivered energy is not double counted.</p>	sum(di.zoneKwh)
generation_kwh	<p>Total generation over the measurement zone.</p> <p>Where base year generation is defined by the AMI data export channels or equivalent data, and forecast generation is directly added to the model and so captured as gross generation connected.</p>	sum(di.genKwh)
generation_cecv	<p>This metric is the same as generation_kwh defined above, multiplied by the relevant Customer Export Curtailment Value (CECV) for each interval. The metric represents the total economic value of avoided market generation.</p>	generation_kwh * CECV
generation_co2	<p>This metric is the same as generation_kwh defined above, multiplied by the relevant the timeseries value of CO2 for each interval. The metric represents the total value of the CO2 avoided from the energy generation market from the generation of local clean energy.</p>	generation_kwh * CO2

**TABLE 10 WEEKLY REPORT TAGS CONTINUED**

<b>COLUMN NAME</b>	<b>DESCRIPTION</b>	<b>FORMULA</b>
gen_exceeding_normal_thermal_voltage_kwh	<p>This metric captures the total generation at risk within a measurement zone due to breaching voltage and thermal limits. Another way to view this metric is as the sum of the largest normal generation overload (voltage or thermal) on an interval-by-interval basis.</p> <p>Only accumulate the largest of each violation in each interval to avoid double counting. The voltage-driven energy used energy scaling as defined above.</p> <p>Default thresholds for 230v base are 216v &lt;&gt; 253v. This is the point at which part of the measurement zone energy is counted as curtailed. The curtailed energy then linearly increases until the outer voltage thresholds are reached, which for 230v base are 207v &lt;&gt; 260v. At this level, 100% of measurement zone generated energy for the relevant intervals is counted as curtailed.</p>	$\text{Sum}(\text{Max}(\text{highScaling} + \text{lowScaling}) * \text{di.genKwh}, \text{di.overloadKwhNormal with negative di.kwh})$
gen_exceeding_normal_thermal_voltage_cecv	<p>This is gen_exceeding_normal_thermal_voltage_kwh multiplied by the relevant Customer Export Curtailment Value (CECV) for each interval the overload is present.</p>	$\text{Sum}(\text{Max}(\text{highScaling} + \text{lowScaling}) * \text{di.genKwh}, \text{di.overloadKwhNormal with negative di.kwh}) * \text{CECV}$
gen_exceeding_normal_thermal_voltage_co2	<p>This is gen_exceeding_normal_thermal_voltage_kwh multiplied by the relevant timeseries value of CO2 for each interval the overload is present.</p>	$\text{Sum}(\text{Max}(\text{highScaling} + \text{lowScaling}) * \text{di.genKwh}, \text{di.overloadKwhNormal with negative di.kwh}) * \text{CO2}$

## 4.1 Model topology

The model outputs are aggregated and sectionalised by:

- Feeder head (such as a feeder circuit breaker)
- Transformer isolator
- Circuit Disconnecter (such as a fuse or isolator)

Energy kWh and dollar (\$) outputs are aggregated to the measurement zone an energy consumer is supplied from. Voltage outputs represent the voltage magnitudes in the measurement zone, irrespective of whether an energy consumer is connected or not. Figure 12 presents our model topology.

**FIGURE 11 MODEL TOPOLOGY USED IN EVALUATION**

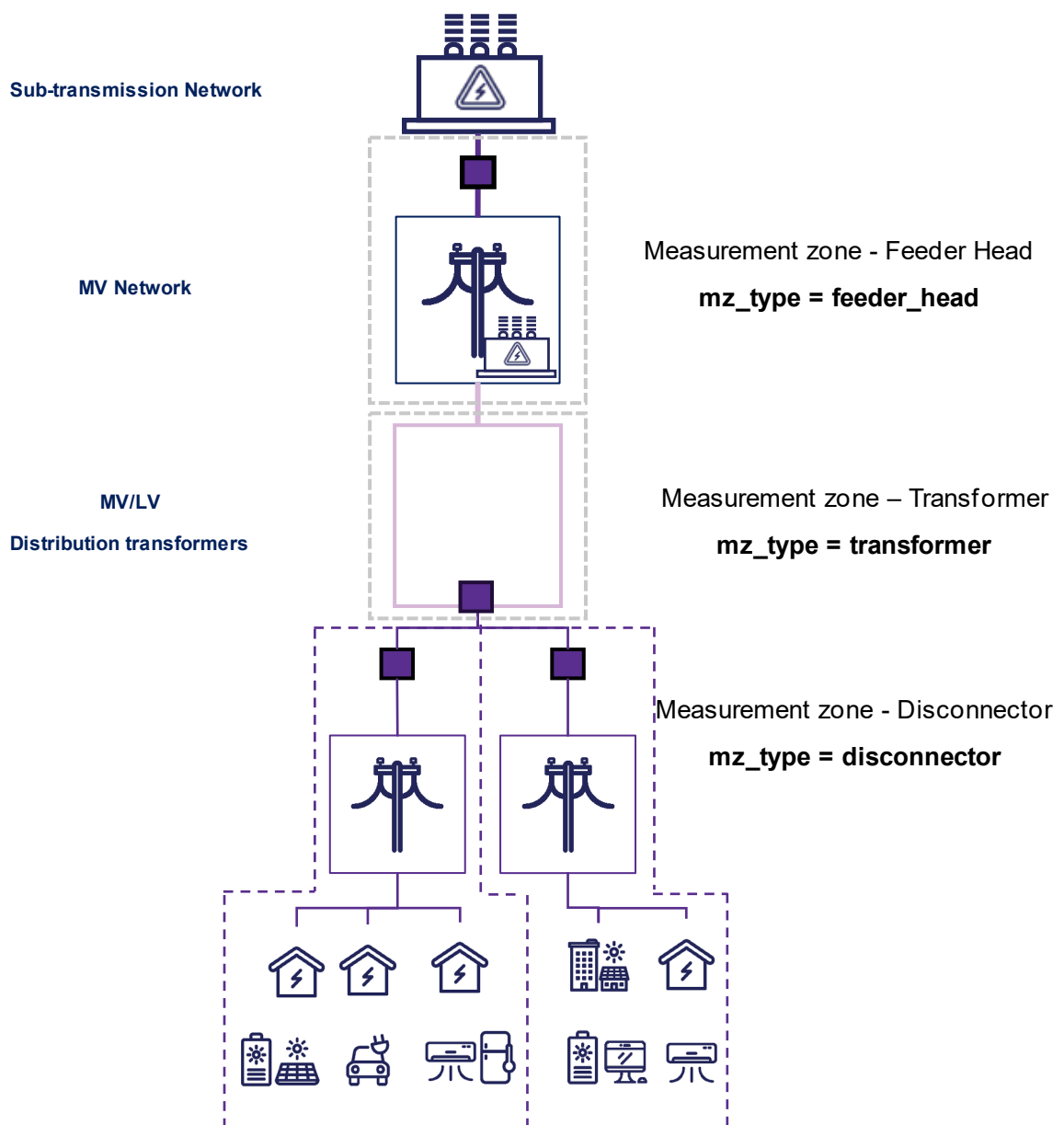

## 5. Our modelling expands beyond power-flow analysis

Distributed computing on AWS was used to execute the power-flow output workflow. This workflow undertakes the electrical to economic assessment and was computed using over 5,000 lines of Python and PySpark code. The pipeline processed large volumes of structured data using Spark on AWS Glue, configured with 240 CPUs and 960 gigabytes of memory distributed across 60 data processing units (workers).

The workflow included distributed data processing, transformations, and integration with mathematical models. It completed the end-to-end process in one hour, handling hundreds of gigabytes of data. Such an optimisation was essential due to the workflow's complexity, requiring hundreds of iterations for development, testing, and debugging. Running the workflow on a single computer would have been prohibitively slow, taking an estimated 50–100 hours and likely exceeding memory limits, as it lacked the parallelism and scale necessary for processing such large datasets efficiently.

By establishing this analytics workflow in AWS we seek to enhance improved fault finding, consistency of results, output coordination and clear version control.

The sequence established is outlined below. Conceptual methodologies for each step are linked to subsequent sections of this methodology.

### 5.1 Data consolidation

We begin by detailing the process of consolidating and cleaning result data from EWB. With approximately over 800 billion data points analysed, this data preparation ensures the foundation for all subsequent modelling and decision-making is robust and reliable. Figure 13 contains our data consolidation process, with links to each sub-section which explains the process in more detail.

FIGURE 12 DATA CONSOLIDATION PROCESS

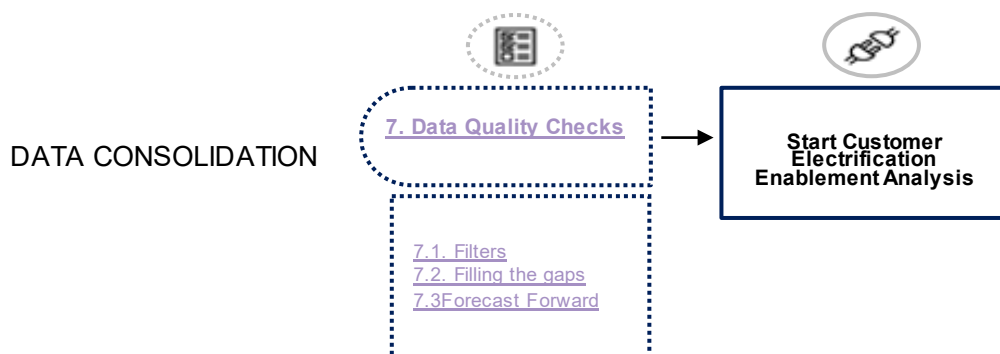

### 5.2 AWS sequence part 1

Here we develop a prioritised list of sites where augmentation is economically viable, leveraging energy-at-risk figures to identify augmentation opportunities. This process directly informs our targeted alleviation strategies, ensuring resources are allocated effectively to areas delivering the most value, shown at figure 14.

**FIGURE 13 AWS SEQUENCE PART 1**

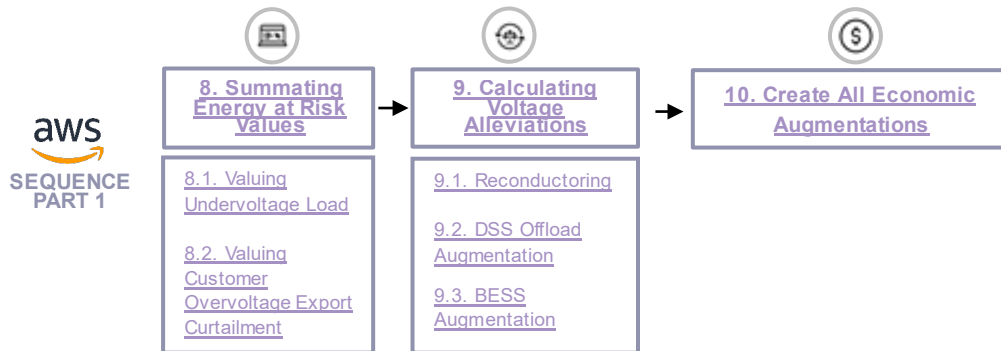

### 5.3 AWS sequence part 2

We model customer voltage compliance to ensure alignment with the Essential Services Commissions (ESC) Victorian Electricity Distribution Code of Practice (VEDCoP). The modelling produces augmentation outcomes designed to meet prescribed customer service levels, ensuring our network remains reliable and compliant under various demand scenarios, shown at .

**FIGURE 14 AWS SEQUENCE PART 2**

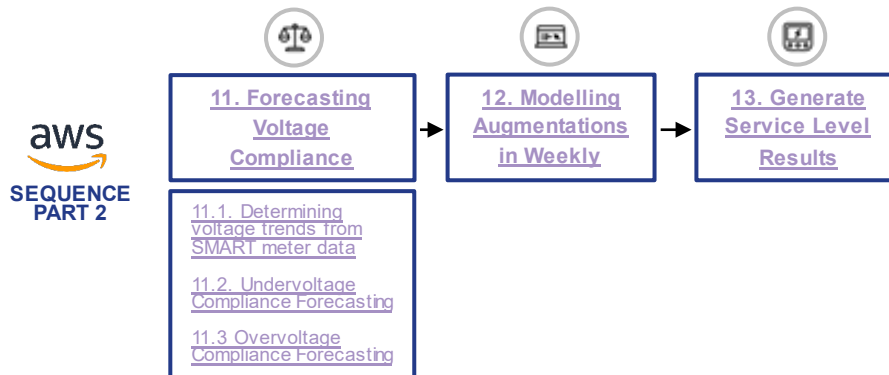

### 5.4 Post proactive modelling

This section highlights our efforts to predict voltage complaints and perform sensitivity analysis on the results. We consider external factors, such as environmental changes or unforeseen demand shifts, to validate the appropriateness of the selected augmentation options, shown at figure 16

**FIGURE 15 POST PROACTIVE MODELLING**

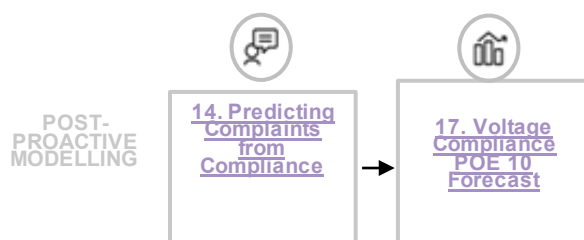



## 5.5 Supporting modelling

Alternative programs of work are evaluated using our supporting models. By leveraging these tools, we justify our chosen strategies, demonstrating how the modelling process contributes to identifying and supporting optimal solutions for network augmentation, shown at figure 17.

**FIGURE 16 SUPPORTING MODELS**

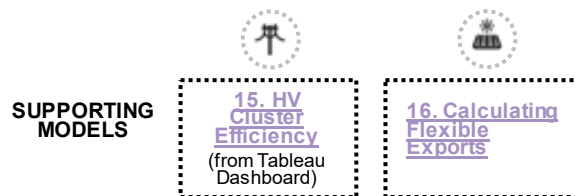

## 6. Data quality checks

Data quality checks are conducted as the initial steps for the post modelling analysis in ensuring that results are not impacted by unreliable outputs. Across the millions of power flow iterations, some power flow non-convergence occurs. Section 7.1 through to section 7.3 explains how we capture this.

### 6.1 Filters

- Solved Feeder-Year
- Converged powerflow model
- Complete input data
- Data Quality Filters:
  - Voltage Filters:
    - $v\_max\_threshold = \{upper\_limit: 300, lower\_limit: 220\}$
    - $v\_min\_threshold = \{upper\_limit: 250, lower\_limit: 150\}$
  - Load Filters:
    - $abs(load\_max\_threshold) < 1e8$
  - Forecast Filters:
    - Feeders and ZSS with Blockloads and Large Generation
    - Feeders and ZSS with Load transfer

### 6.2 Filling the gaps

1. Fill forward using the last valid results for each mrid
  - i. Find the last valid full-year results for each mrid
  - ii. Replace the mrid-years that are filtered with the latest valid full-year result for each mrid
2. Figure 18 shows how data is corrected.

**FIGURE 17 DATA CORRECTION EXAMPLE**

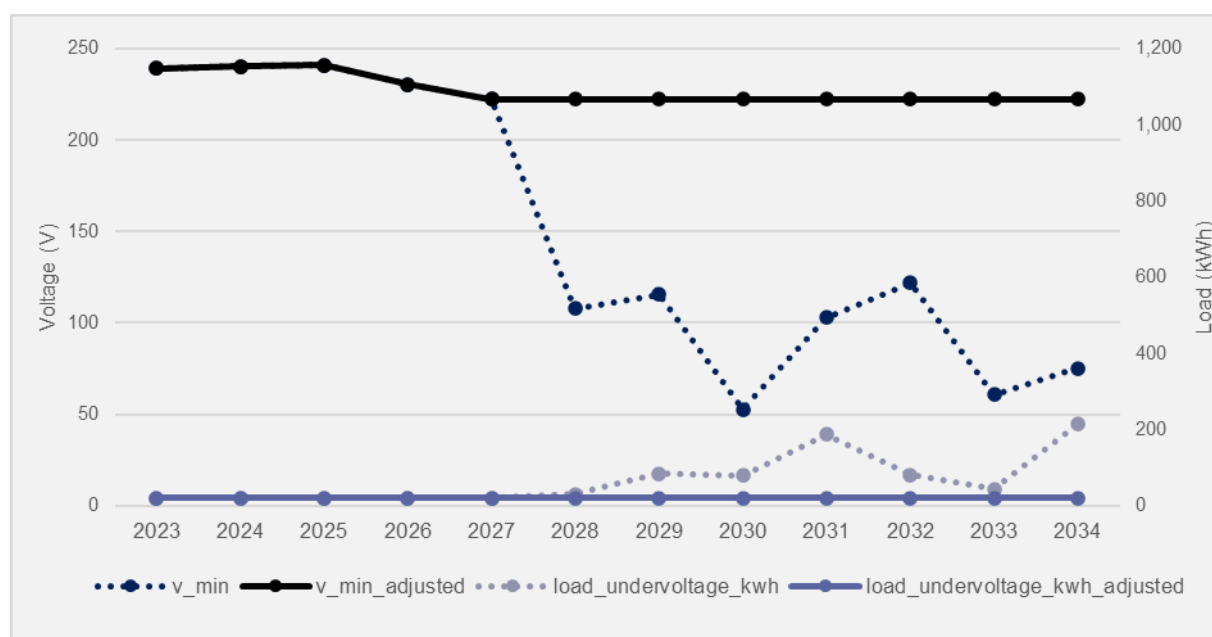

### 6.3 Forecast forward

- i. Filter all the solved records
- ii. Aggregate the mrid voltage compliance data to network weekly compliance data.
- iii. Take the year-to-year trend for each week at network level.
- iv. Filter the mrids that have been forward-filled in the previous step.
- v. Apply the network level, year-to-year trend on weekly basis (step iii) on these records.
- vi. Replace the forward-filled records with calculated forecast-forward-fill.

# 7. Summating energy at risk values

## 7.1 Valuing undervoltage load

The load undervoltage formula is used to calculate the total energy of risk for importing customers experiencing voltage less than 216V over the forecasted year. Figure 19 shows an example of daily voltage.

FIGURE 18 EXAMPLE VOLTAGE FLOW (V)

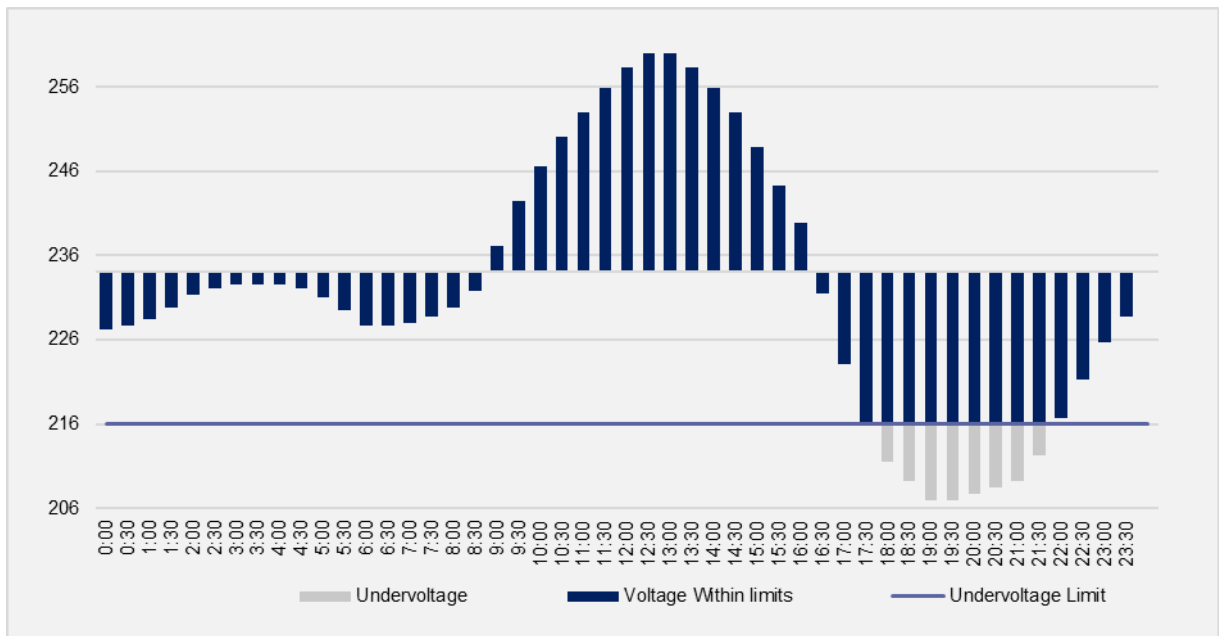

To calculate energy at risk, results are produced in kWh of load, shown in Figure 20

FIGURE 19 EXAMPLE UNDERVOLTAGE ENERGY AT RISK (KWH)

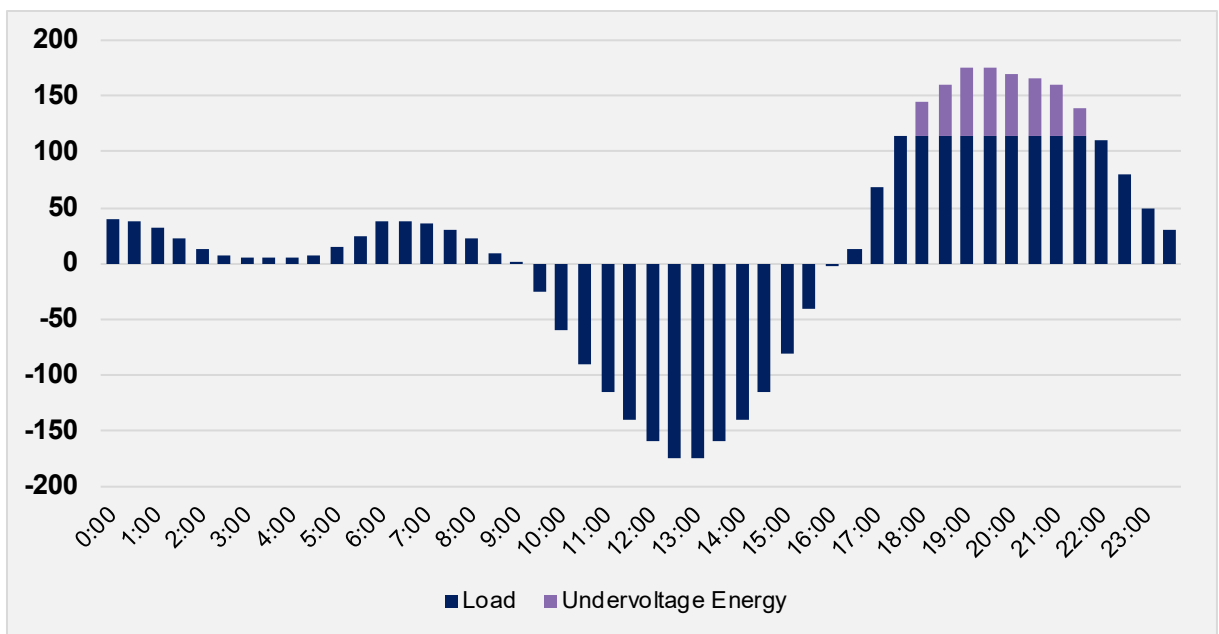

For reference, the tags used for this section of the model are at Table 11.

**TABLE 11 UNDERVOLTAGE TAGS**

TAG	UNIT	SOURCE TABLE
mz_type		Network Performance Metrics
load_undervoltage_normal_kwh	kwh	Network Performance Metrics
VCR	\$/kWh	AER/ aligned to Zone Substation

**7.1.1 Formulae**

Energy at risk is scaled by voltage linearly from 0% to 100% total energy at risk, illustrated in figure 21.

**FIGURE 20 SCALING OF ENERGY LOST TO UNDERVOLTAGE (V)**

This scaling is applied to the load\_undervoltage\_normal\_kwh as described in section 5.1

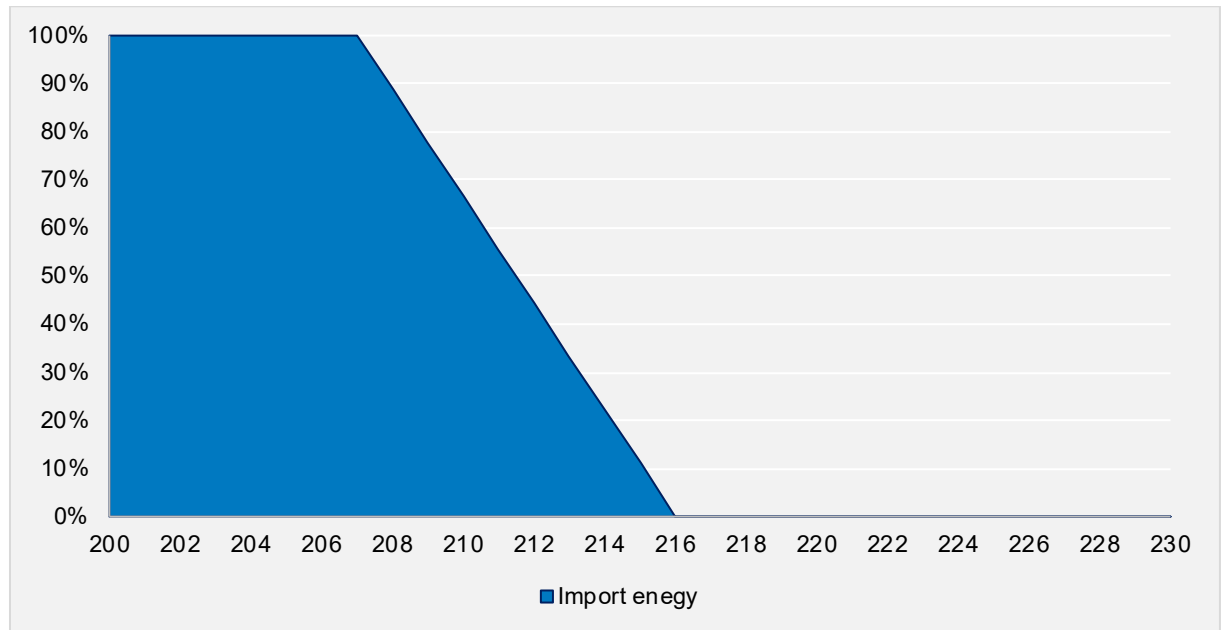

Energy at risk is then multiplied by the Value of Customer Reliability (VCR) to provide a total dollar cost, at Equation 1.

**EQUATION 1 COST OF UNDERVOLTAGE ENERGY**

For mz\_type = ‘DISCONNECTOR’ or ‘TRANSFORMER’:

$$import\_energy\_at\_risk\_vcr (\$) = \sum_{Mar}^{Apr} (load\_undervoltage\_normal\_kwh_{V < 216}) \times VCR$$

**7.1.2 Assumptions**

- Zone Substations without a VCR use the network default value of VCR (\$/kWh).

## 7.2 Valuing customer overvoltage export curtailment

This section values solar exports that would experience overvoltage should it be approved for export. Current network procedure export limits new connections before network limits bind to prevent export driven overvoltage from occurring. Therefore, it is represented as an augmentation enablement opportunity.

Figure 22 exemplifies our approach to overvoltage observed on our network.

**FIGURE 21 EXAMPLE OVERVOLTAGE (V)**

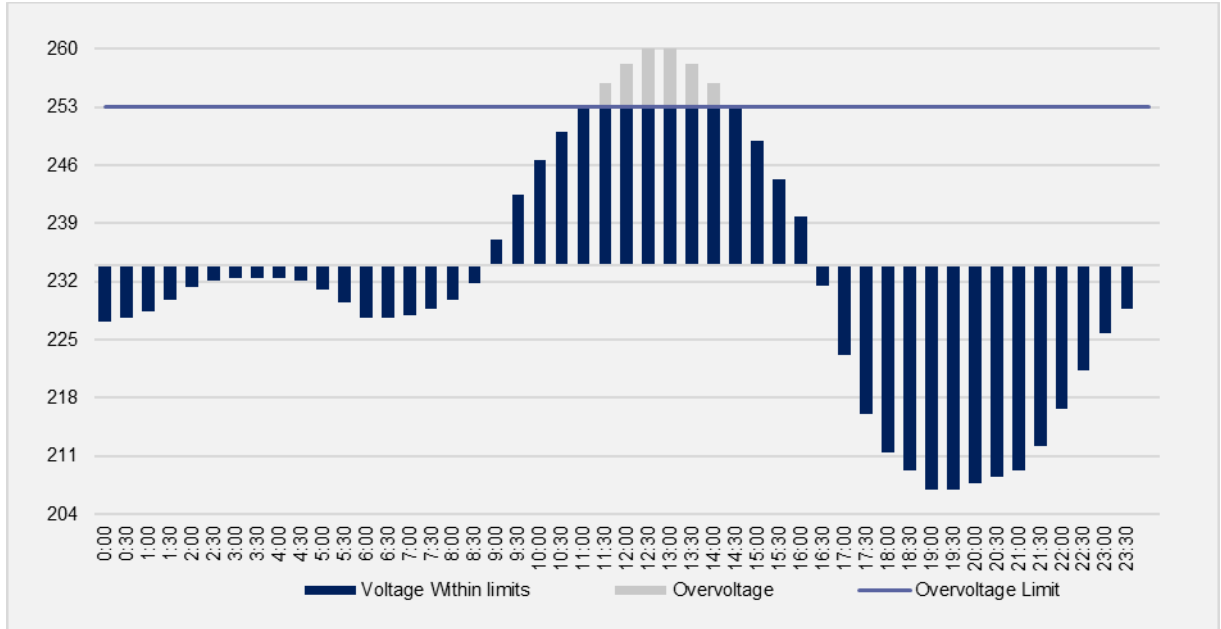

To calculate energy at risk, results are produced in kWh of load, shown in Figure 23.

**FIGURE 22 EXAMPLE OVERVOLTAGE ENERGY AT RISK (KWH)**

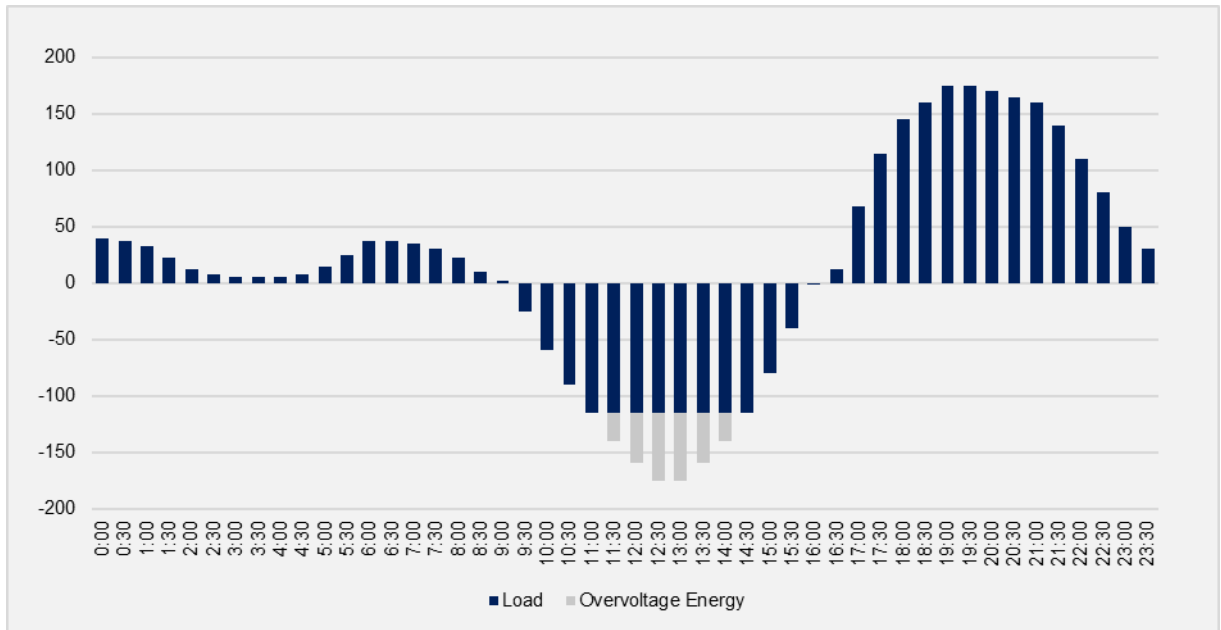

For reference, the tags used for this section of the model are at Table 12.

**TABLE 12    OVERVOLTAGE TAGS**

TAG	UNIT	SOURCE TABLE
mz_type		Network Performance Metrics
gen_overnoltage_kwh	kWh	Network Performance Metrics
gen_overnoltage_cecv	\$	Network Performance Metrics
gen_overnoltage_co2	\$	Network Performance Metrics

**7.2.1    Formulae**

**FIGURE 23    SCALING OF ENERGY LOST TO OVERVOLTAGE (V)**

This scaling is applied to the gen\_overnoltage\_kwh as described in section 5.1

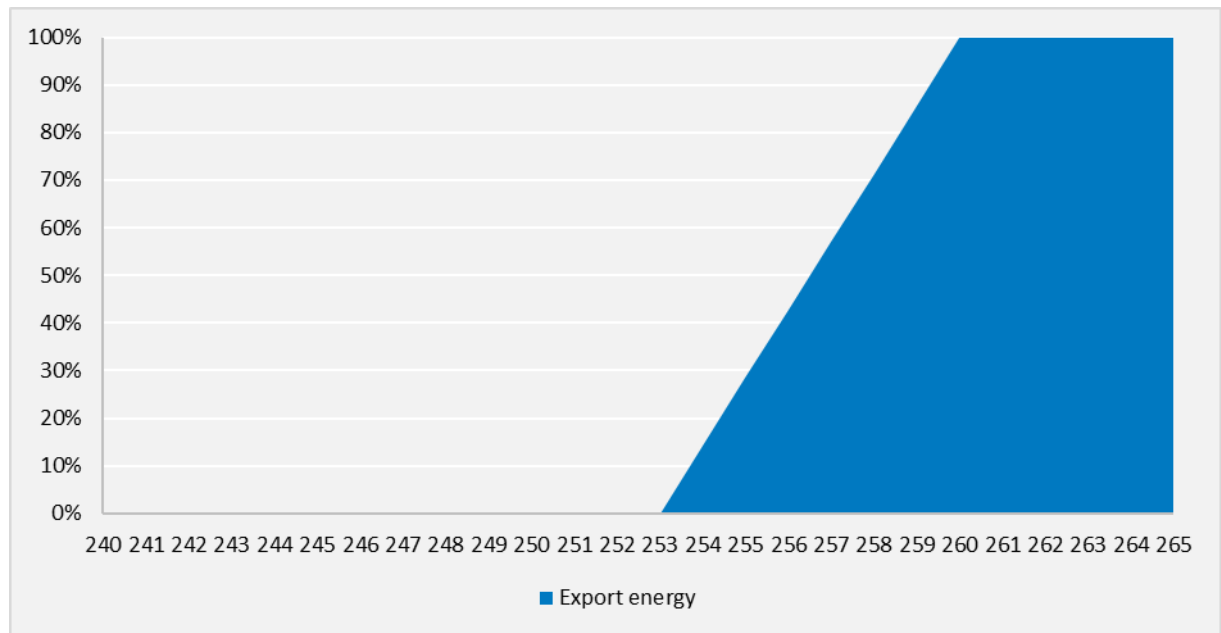

Energy at risk is the multiplied by the CECV and carbon reduction value to provide a dollar cost of solar export curtailment, at Equation 2.

**EQUATION 2    COST OF SOLAR EXPORT CURTAILMENT**

- $$Export\ Curtailment\ Cost\ (\$) = \sum_{5pm}^{7am} (gen\ overvoltage\ kwh \times (CECV + Carbon\ Reduction\ Value) )$$

gen\_overnoltage\_kwh is excess solar lost (for each half hour period) in each year  
 CECV half hourly = time series CECV (Victorian \$/MWh t=30min) = gen\_overnoltage\_cecv  
 Carbon Reduction Value (\$/MWh) = gen\_overnoltage\_co2

**7.2.2    Assumptions**

- AS4777.2 (2020) Volt-Var Curve Response is modelled for all new installations.

## 8. Calculating voltage alleviations

This section presents three options to address non-compliant customer voltage levels. Each option includes a high-level overview, a corresponding mathematical expression, the tags used in our coding framework, and an example output illustrating how the solution operates on an affected asset.

### 8.1 Reconductoring augmentation

This calculates the total voltage alleviation benefits from upgrading small and weak conductor to strong all aluminium conductors. This provides a voltage benefit to upper and lower voltages over the course of the year, reducing the overall spread on the circuit.

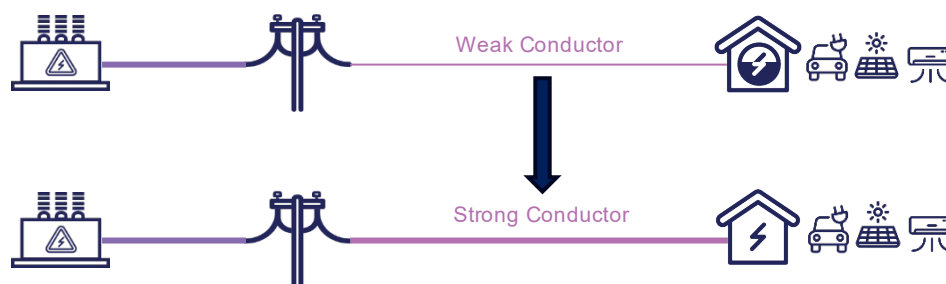

#### 8.1.1 Formulae

All circuits are assessed for reconductoring by using the following criteria, irrespective of voltage conditions:

load\_undervoltage\_normal\_kwh > 0 or load\_undervoltage\_normal\_kwh > 0 measurement\_values = { gen\_overnoltage\_kwh, gen\_overnoltage\_cecv, gen\_overnoltage\_co2, load\_undervoltage\_normal\_kwh, import\_energy\_at\_risk\_vcr }

#### EQUATION 3 CONVERTING PER UNIT VOLTAGE

$$\text{maximum voltage} = \frac{\text{maximum section voltage} \times v \text{ base}}{\sqrt{3}}$$

$$\text{minimum voltage} = \frac{\text{minimum section voltage} \times v \text{ base}}{\sqrt{3}}$$

#### EQUATION 4 RECONDUCTORING VOLTAGE ALLEVIATION

$$\text{Voltage Spread Reduction} = 9V \times 2 = 18V$$

#### EQUATION 5 RECONDUCTORING ENERGY BENEFITS

$$\text{Voltage Spread Reduction Required} = (\text{maximum\_voltage} - \text{minimum\_voltage}) - 37V$$

$$\text{Energy Metric's Alleviation Ratio} = \min\left(\frac{\text{Voltage Spread Reduction}}{\text{Voltage Spread Reduction Required}}, 100\%\right)$$

$$\text{Alleviation Voltage Energy Values} = \text{Energy Metric's Alleviation Ratio} \times \text{measurement values}$$

For reference, the tags used for this section of the model are at Table 13.

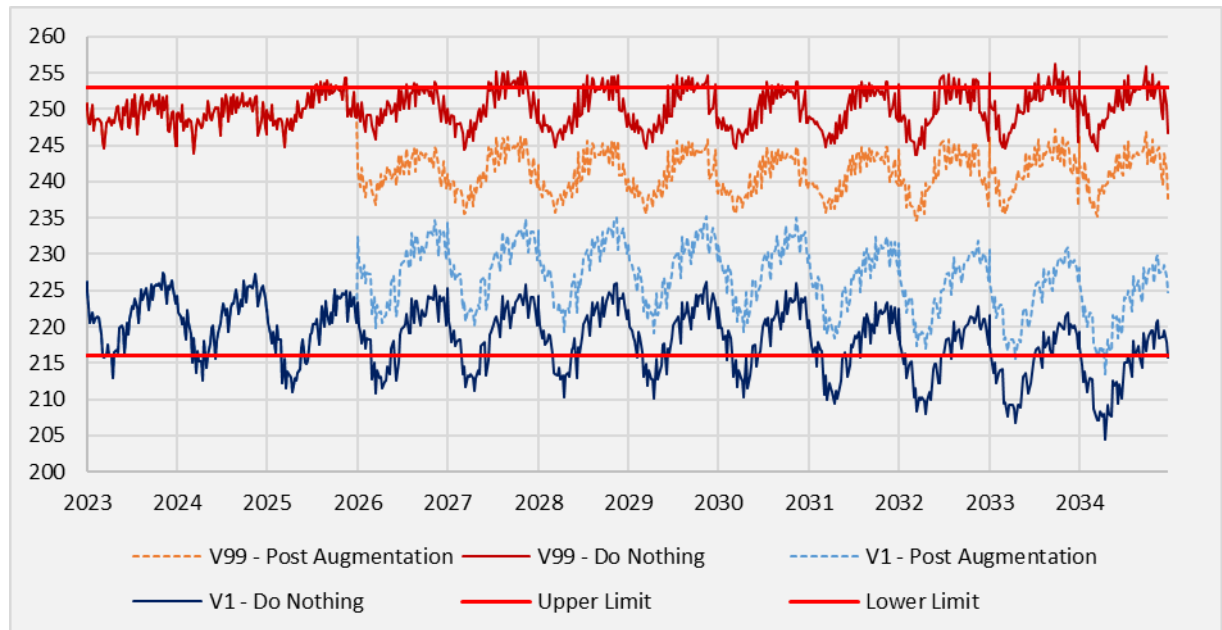

**TABLE 13 RECONDUCTORING ALLEVIATION TAGS**

TAG	UNIT	SOURCE TABLE
mz_type		Network Performance Metrics
v_base	V	Network Performance Metrics
maximum_section_voltage	p.u	Network Performance Metrics
minimum_section_voltage	p.u	Network Performance Metrics
gen_overnoltage_kwh	kWh	Network Performance Metrics
gen_overnoltage_cecv	\$	Network Performance Metrics
gen_overnoltage_co2	\$	Network Performance Metrics
load_undervoltage_normal_kwh	kWh	Network Performance Metrics
import_energy_at_risk_vcr	\$	Calculated in section 8

Figure 25 contains the output we produce from our reconductoring alleviation modelling.

**FIGURE 24 RECONDUCTORING ALLEVIATION (V)**



### 8.1.2 Assumptions

- Reconductoring will improve the voltage spread between minimum and maximum voltages by 18V (9V reduction in maximum voltage and 9V increase in minimum voltage).
- The transformer tap position will be optimised for the transformer at the time of augmentation.

## 8.2 DSS offload augmentation

This calculates the total voltage alleviation benefits from introducing additional substations to reduce import and export voltage constraints existing substations. This provides a voltage benefit to upper and lower voltages over the course of the year, reducing the overall spread on the circuit. Figure 26 demonstrates the impact of this process.

**FIGURE 25 IMPACT OF AN ADDITIONAL DISTRIBUTION SUBSTATION**

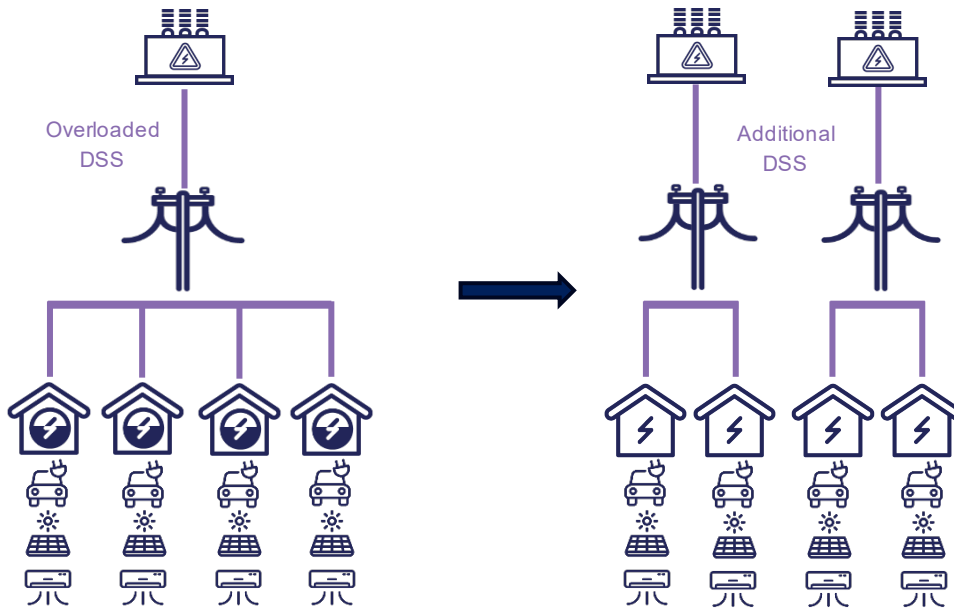

### 8.2.1 Formulae

All circuits are assessed for DSS offload by using the following criteria, irrespective of voltage conditions.

load\_undervoltage\_normal\_kwh > 0 or load\_undervoltage\_normal\_kwh > 0 measurement\_values = { gen\_overnoltage\_kwh, gen\_overnoltage\_cecv, gen\_overnoltage\_co2, load\_undervoltage\_normal\_kwh, import\_energy\_at\_risk\_vcr }

#### EQUATION 6 CONVERTING PER UNIT VOLTAGE

$$\text{maximum voltage} = \frac{\text{maximum section voltage} \times v \text{ base}}{\sqrt{3}}$$

$$\text{minimum voltage} = \frac{\text{minimum section voltage} \times v \text{ base}}{\sqrt{3}}$$

#### EQUATION 7 DSS OFFLOAD VOLTAGE ALLEVIATION

$$\text{Voltage Spread Reduction} = \frac{(\text{maximum\_voltage} - \text{minimum\_voltage})}{2}$$

#### EQUATION 8 DSS OFFLOAD ENERGY BENEFITS

$$\text{Voltage Spread Reduction Required} = (\text{maximum\_voltage} - \text{minimum\_voltage}) - 37V$$

$$\text{Energy Metric's Alleviation Ratio} = \min\left(\frac{\text{Voltage Spread Reduction}}{\text{Voltage Spread Reduction Required}}, 100\%\right)$$

$$\text{Alleviation Voltage Energy Values} = \text{Energy Metric's Alleviation Ratio} \times \text{measurement values}$$

For reference, the tags used for this section of the model are at table 14.

**TABLE 14 DSS OFFLOAD ALLEVIATION TAGS**

TAG	UNIT	SOURCE TABLE
mz_type		Network Performance Metrics
v_base	V	Network Performance Metrics
maximum_section_voltage	p.u	Network Performance Metrics
minimum_section_voltage	p.u	Network Performance Metrics
gen_overnormalization_kwh	kWh	Network Performance Metrics
gen_overnormalization_cecv	\$	Network Performance Metrics
gen_overnormalization_co2	\$	Network Performance Metrics
load_undervoltage_normal_kwh	kWh	Network Performance Metrics
import_energy_at_risk_vcr	\$	Calculated in section 8

Figure 27 contains the output we produce from our DSS offload alleviation modelling.

**FIGURE 26 DSS OFFLOAD ALLEVIATION PROFILE (V)**

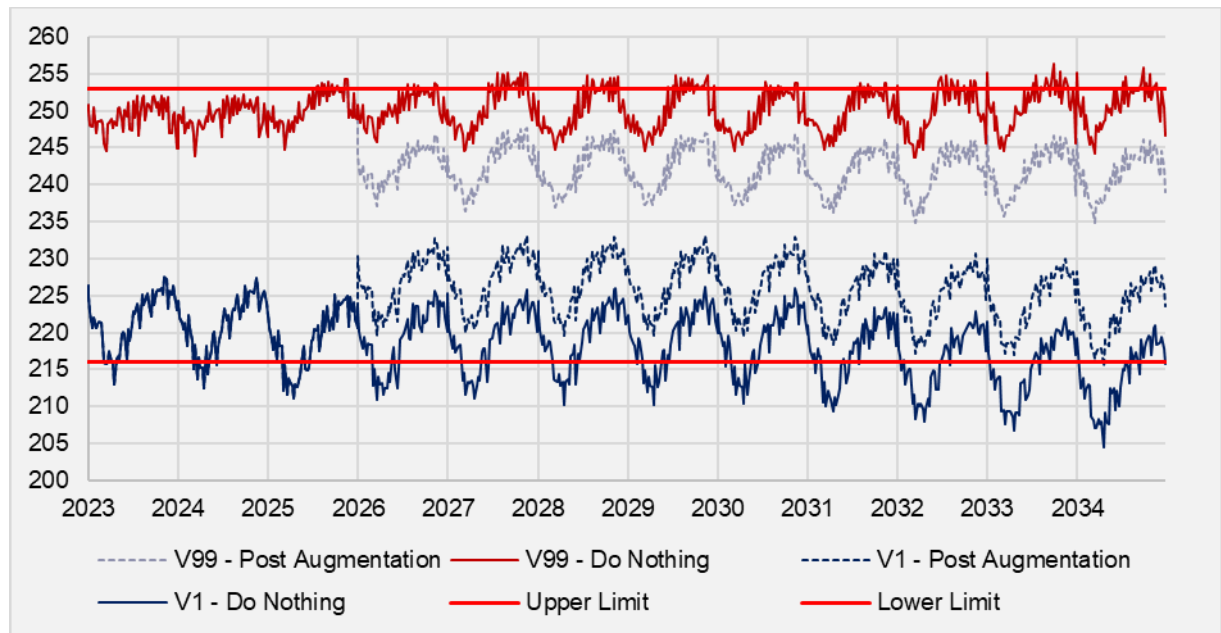

### 8.2.2 Assumptions

- Introducing an additional DSS will halve the voltage spread and the load on the circuit.

- The transformer tap position will be optimised for the transformer at the time of augmentation.

### 8.3 BESS augmentation

This calculates the total voltage alleviation benefits of installing a Battery Energy Storage System (BESS) import and export voltage constraints existing substations. This provides a voltage benefit to upper and lower voltages over the course of the year, reducing the overall spread on the circuit. Figure 33 visualises the impact of BESS augmentation.

FIGURE 27 IMPACT OF BESS AUGMENTATION

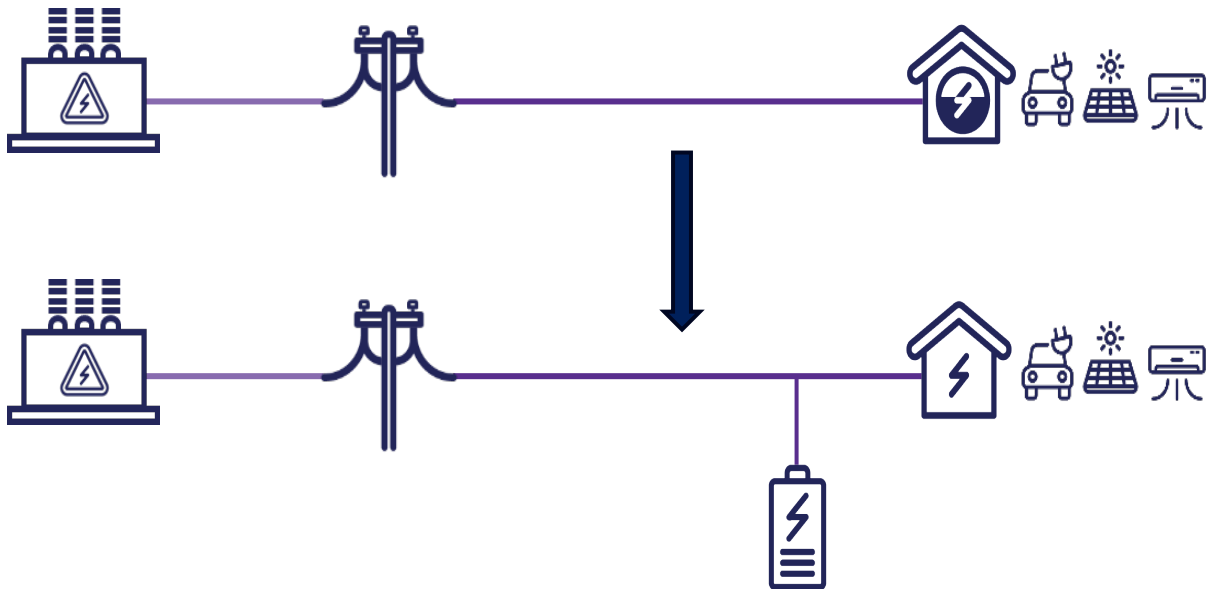

#### 8.3.1 Formulae

All circuits are assessed for reconductoring by using the following criteria, irrespective of voltage conditions.

load\_undervoltage\_normal\_kwh > 0 or load\_undervoltage\_normal\_kwh > 0 measurement\_values = { gen\_overnoltage\_kwh, gen\_overnoltage\_cecv, gen\_overnoltage\_co2, load\_undervoltage\_normal\_kwh, import\_energy\_at\_risk\_vcr }

#### EQUATION 9 CONVERTING PER UNIT VOLTAGE

$$\text{maximum voltage} = \frac{\text{maximum section voltage} \times v \text{ base}}{\sqrt{3}}$$

$$\text{minimum voltage} = \frac{\text{minimum section voltage} \times v \text{ base}}{\sqrt{3}}$$

#### EQUATION 10 BESS VOLTAGE ALLEVIATION

$$\text{Voltage Spread Reduction} = 6V \times 2 = 12V$$

#### EQUATION 11 BESS ENERGY BENEFITS

$$\text{Voltage Spread Reduction Required} = (\text{maximum\_voltage} - \text{minimum\_voltage}) - 37V$$

$$\text{Energy Metric's Alleviation Ratio} = \min\left(\frac{\text{Voltage Spread Reduction}}{\text{Voltage Spread Reduction Required}}, 100\%\right)$$

$$\text{Alleviation Voltage Energy Values} = \text{Energy Metric's Alleviation Ratio} \times \text{measurement values}$$

For reference, the tags used for this section of the model are at table 15.

**TABLE 15 BESS ALLEVIATION TAGS**

TAG	UNIT	SOURCE TABLE
mz_type		Network Performance Metrics
v_base	V	Network Performance Metrics
maximum_section_voltage	p.u	Network Performance Metrics
minimum_section_voltage	p.u	Network Performance Metrics
gen_overnoltage_kwh	kWh	Network Performance Metrics
gen_overnoltage_cecv	\$	Network Performance Metrics
gen_overnoltage_co2	\$	Network Performance Metrics
load_undervoltage_normal_kwh	kWh	Network Performance Metrics
import_energy_at_risk_vcr	\$	Calculated in section 8

### 8.3.2 Output

The output of BESS alleviation calculations is at figure 29.

**FIGURE 28 BESS ALLEVIATION PROFILE (V)**

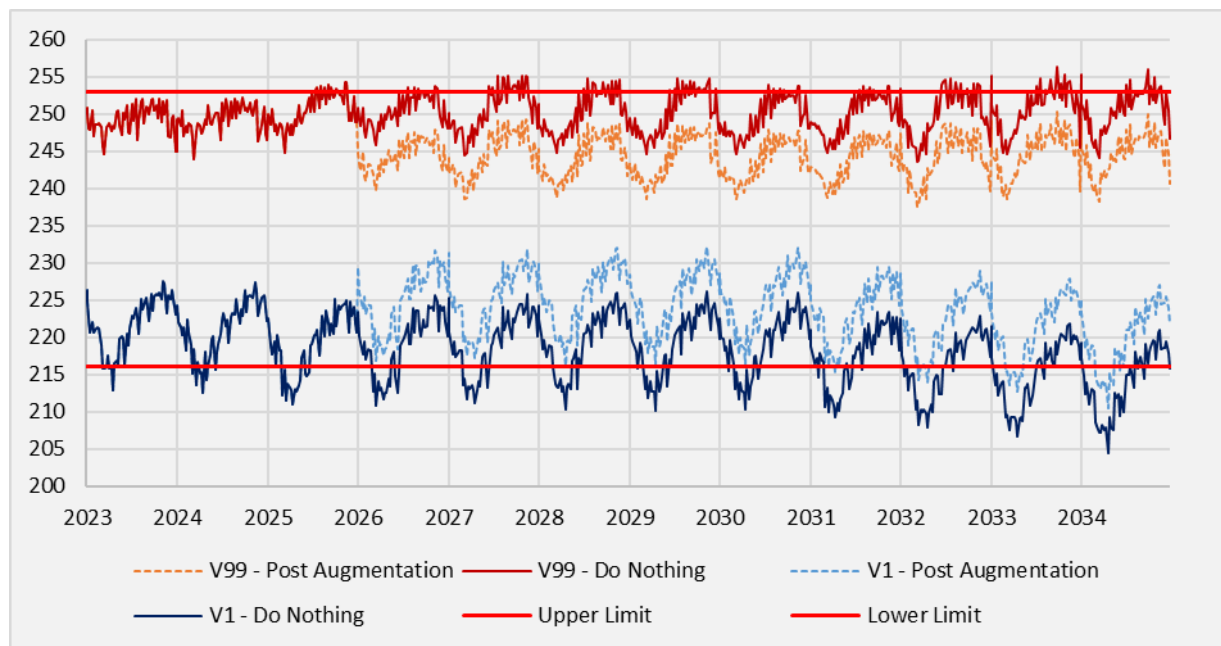

### **8.3.3 Assumptions**

- A BESS will improve the voltage spread between minimum and maximum voltages by 12V (6V reduction in maximum voltage and 6V increase in minimum voltage).
- The transformer tap position will be optimised for the transformer at the time of augmentation.

## 9. Evaluate all economic augmentations

An economic assessment is undertaken for each low voltage circuit to generate a list of economic augmentations including the economic year. The economic timing of circuit augmentation is calculated by comparing the first year the benefit of an augmentation exceeds the annualised cost of augmentation. We ensure our portfolio of projects is efficient by selecting the augmentation project that will deliver the highest net benefit to customers, at the lowest cost.

Figure 30 visualises our economic timing analysis.

**FIGURE 29 AUGMENTATION ECONOMIC TIMING ANALYSIS**

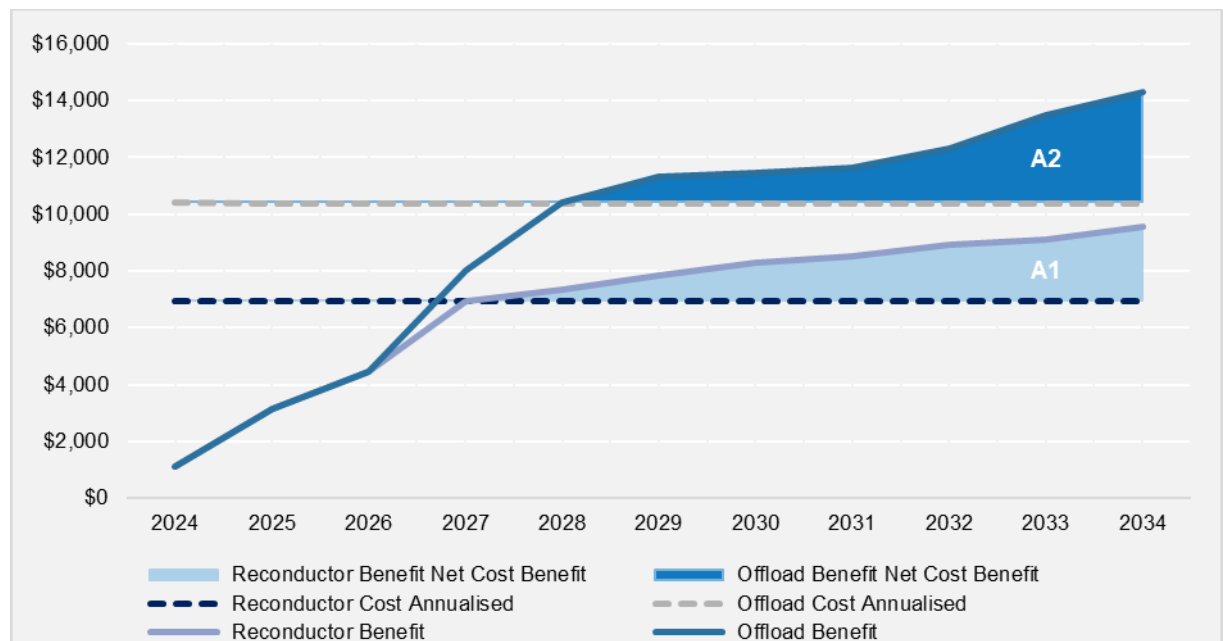
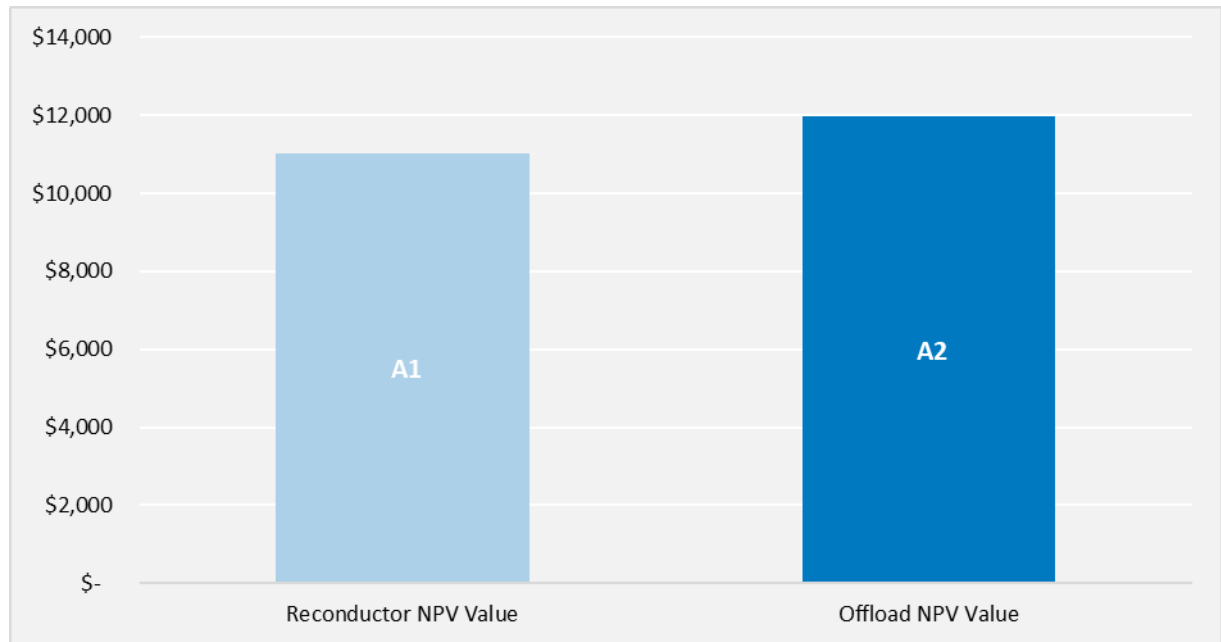

Figure 26 shows that we would select option A2 as it has a higher net present value when compared to A1.

**FIGURE 30 AUGMENTATION SELECTION**



## 9.1 Formulae

Equations Equation 12, Equation 13 and Equation 14 contain the formulae to calculating the net benefit of our alleviation projects.

### EQUATION 12 AUGMENTATION ANNUALISED COST

$$reconductor\_annualised\_cost = \frac{reconductor\_cost \times WACC}{(1 - (1 + WACC))^{(-1 \times payback\_years)}}$$

$$dss\_offload\_annualised\_cost = \frac{offload\_cost \times WACC}{(1 - (1 + WACC))^{(-1 \times payback\_years)}}$$

### EQUATION 13 AUGMENTATION BENEFITS

$$\begin{aligned} &reconductor\_benefits \\ &= reconductor\ alleviation - export\_overvoltage\_only\_cecv \\ &\quad + reconductor\ alleviation - export\_overvoltage\_only\_co2 \\ &+ reconductor\ alleviation - import\_undervoltage\_only\_vcr \end{aligned}$$

$$\begin{aligned} &dss\_offload\_benefits \\ &= dss\_offload\ alleviation - export\_overvoltage\_only\_cecv \\ &\quad + dss\_offload\ alleviation - export\_overvoltage\_only\_co2 \\ &+ dss\_offload\ alleviation - import\_undervoltage\_only\_vcr \end{aligned}$$

### EQUATION 14 AUGMENTATION NET COST BENEFIT CALCULATION

$$reconductor\_net\_cost\_benefits = reconductor\_benefits - reconductor\_annualised\_cost$$

$$dss\_offload\_net\_cost\_benefits = dss\_offload\_benefits - dss\_offload\_annualised\_cost$$

Table 16 contains the capital expenditure to deliver selected augmentation projects.



**TABLE 16 AUGMENTATION CAPITAL EXPENDITURE VALUES (\$)**

<b>DISTRIBUTOR</b>	<b>RECONDUCTOR COST (\$)</b>	<b>DSS OFFLOAD (\$)</b>	<b>RURAL DSS OFFLOAD (\$)</b>
Powercor	\$80,000	\$100,000	\$60,000
CitiPower	\$150,000	\$160,000	N/A
United Energy	\$100,000	\$130,000	N/A

## 9.2 Assumptions

Assumptions in our modelling to calculate the net benefit of proposed augmentations are below:

- Weighted Average Cost of Capital is 3.5%
- Augmentation payback period is 15 years

## 10. Forecasting voltage compliance

The relationship between percentile voltages (v1\_avg and v99\_avg) and customer compliance at a localised lv level is important for transforming weekly outputs from table 7 into customer compliance values. To obtain the trend, actual compliance results for four different weeks are aggregated to a distribution substation (DSS) level and joined to the corresponding v1\_avg and v99\_avg for the DSS in the given week.

The four weeks selected maintained the following criteria:

- Peak load summer week
- Peak load winter week
- Light load spring week
- High compliance autumn week

The results are grouped by total customers supplied by a DSS and a sigmoid function is then fitted, as shown in Figure 32 and Figure 34, to determine relationship between v1\_avg and undervoltage compliance (%), and v99\_avg and overvoltage compliance (%).

### 10.1 Undervoltage Equations

Equation 15 and Figure 32 contains our approach to translating undervoltage to compliance.

#### EQUATION 15 UNDERVOLTAGE COMPLIANCE SIGMOID FUNCTION

$$V1 \text{ Compliance } (\%) = \frac{1}{1 + e^{-k(v_{1avg} - x_0)}}$$

FIGURE 31 UNDERVOLTAGE COMPLIANCE AND V1 AVG DATA WITH FITTED SIGMOID CURVE

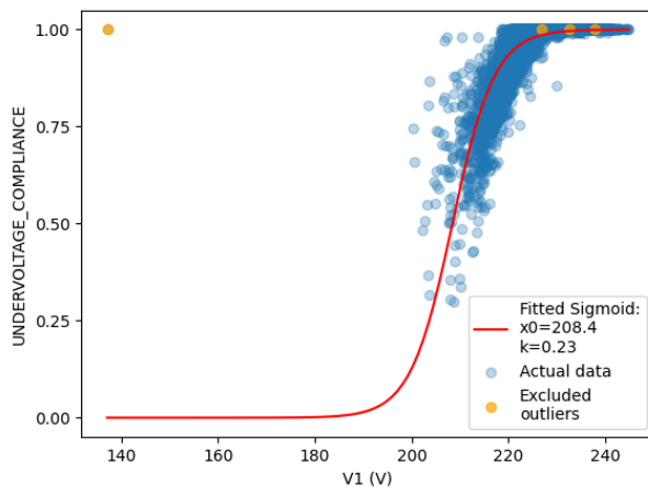

This yields trends in Figure 33 for modelling undervoltage compliance for each customer group.

**FIGURE 32 UNDERVOLTAGE SIGMOID COMPLIANCE CURVES (V)**

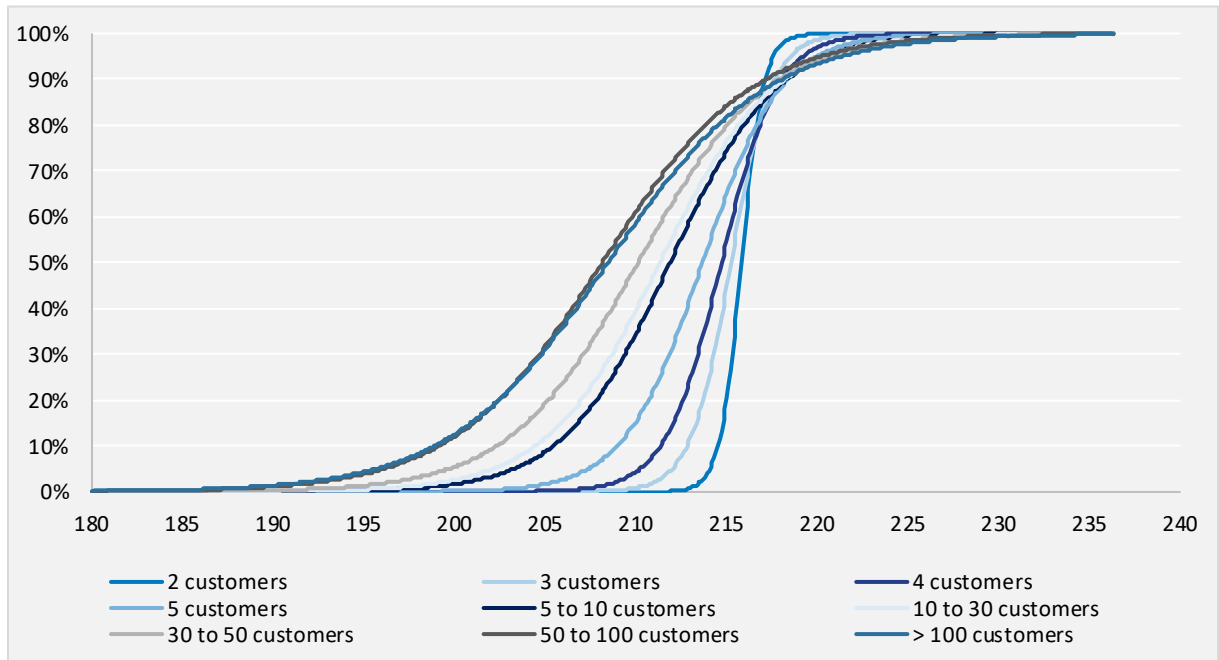

### 10.1.1 Overvoltage Equations

Equation 16 and Figure 34 contain our approach to translating overvoltage to compliance.

#### EQUATION 16 OVERVOLTAGE COMPLIANCE SIGMOID FUNCTION

$$V99 \text{ Compliance } (\%) = \frac{1}{1 + e^{-k(v99_{avg} - x_0)}}$$

**FIGURE 33 OVERVOLTAGE COMPLIANCE AND V99 AVG DATA WITH FITTED SIGMOID CURVE**

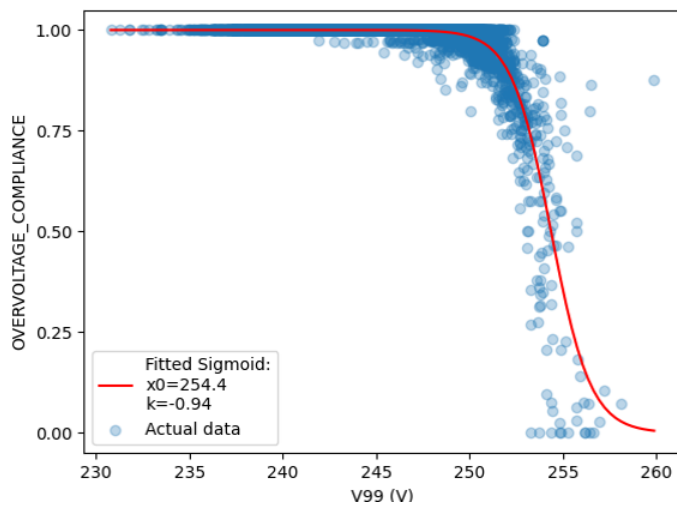

From here, we obtain overvoltage sigmoid functions per customer group as shown in Figure 35.

**FIGURE 34    OVERVOLTAGE SIGMOID COMPLIANCE CURVES (V)**

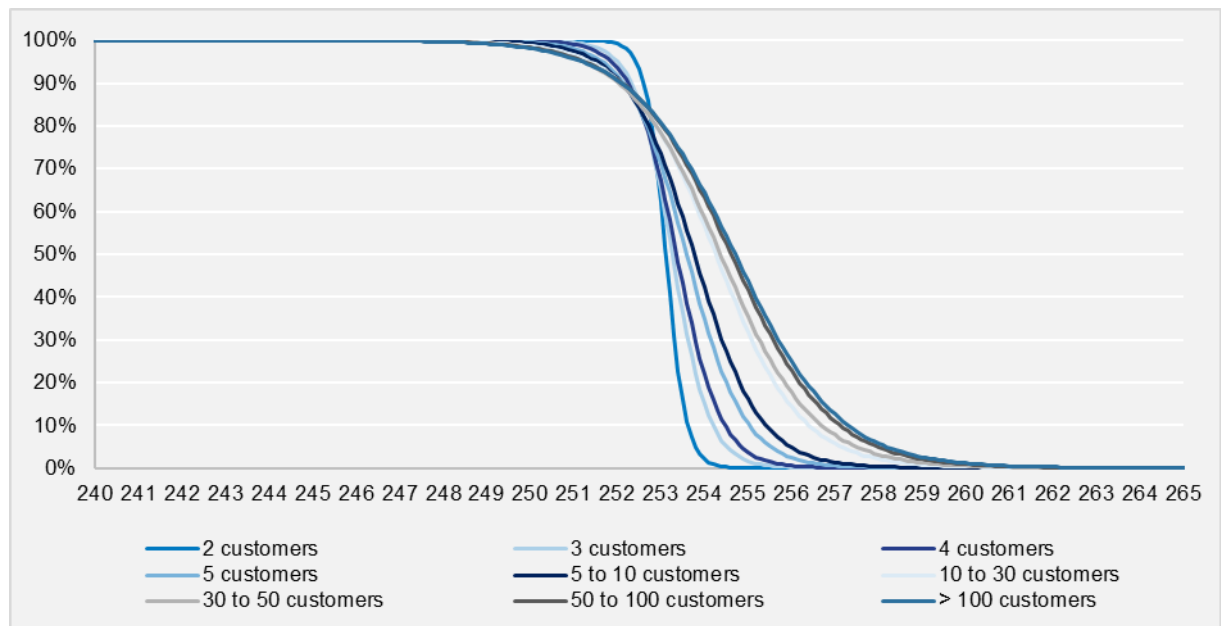

## 10.2 Undervoltage compliance forecasting

Network undervoltage compliance forecast is modelled to examine impacts electrification will have on customer service levels. Using outputs from the EWB model and voltage trends from aggregated SMART meter data, compliance forecasting adopts a bottom-up approach, determining the number of compliant customers at a circuit level for each week and rolled up to the network level.

Outputs of this are at Figure 36.

**FIGURE 35 UNDERVOLTAGE COMPLIANCE OUTPUT**

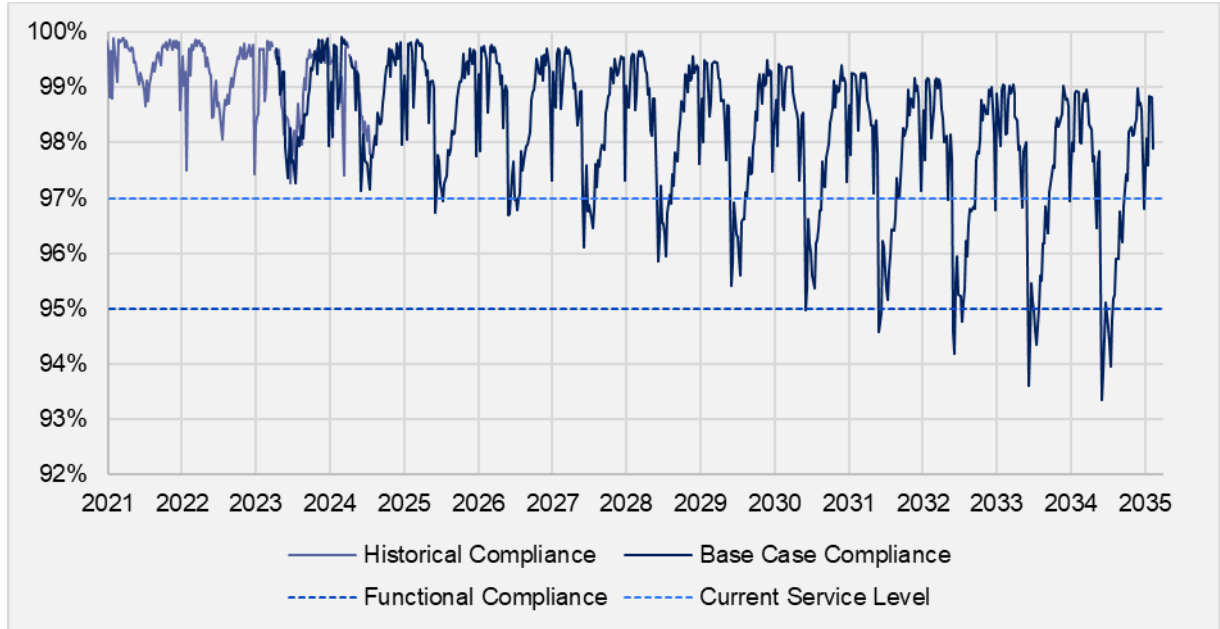

Equation 17 and Equation 18 contain our approach to forecasting undervoltage compliance.

### EQUATION 17 V1 AVERAGE VOLTAGE

$$v1 \text{ avg value} = \frac{v1 \text{ avg} \times v \text{ base}}{\sqrt{3}}$$

### EQUATION 18 UNDERVOLTAGE CUSTOMER COMPLIANCE

$$V1 \text{ Compliance (\%)} = \frac{1}{1 + e^{-k(v1 \text{ avg value} - x0)}}$$

$$\begin{aligned} & \text{Undervoltage Compliant customers} \\ & = V1 \text{ Compliance} \times \text{'Customer Count'}, (\text{rounded to nearest customer}) \end{aligned}$$

For each week, sum the total number of unconstrained customers and divide by total customers to obtain network compliance for a given week.

For reference, the tags used for this section of the model are at Table 17.

**TABLE 17      UNDERVOLTAGE COMPLIANCE TAGS**

<b>TAG</b>	<b>UNIT</b>	<b>SOURCE TABLE</b>
conducting_equipment_mrid	N/A	Weekly Report
mz_type	N/A	Weekly Report
v_base	V	Weekly Report
v1_avg	p.u	Weekly Report
Timestamp	dd-mm-yyyy	Weekly Report

### 10.3 Overvoltage compliance forecasting

Network overvoltage compliance forecast is modelled to examine impacts of unconstrained solar PV uptakes will have on overvoltage limits. Using outputs from the EWB model and voltage trends from aggregated SMART meter data, compliance forecasting adopts a bottom-up approach, determining the number of compliant customers at a circuit level for each week and rolled up to the network level.

Figure 37 shows over overvoltage compliance output.

**FIGURE 36 OVERVOLTAGE COMPLIANCE OUTPUT**

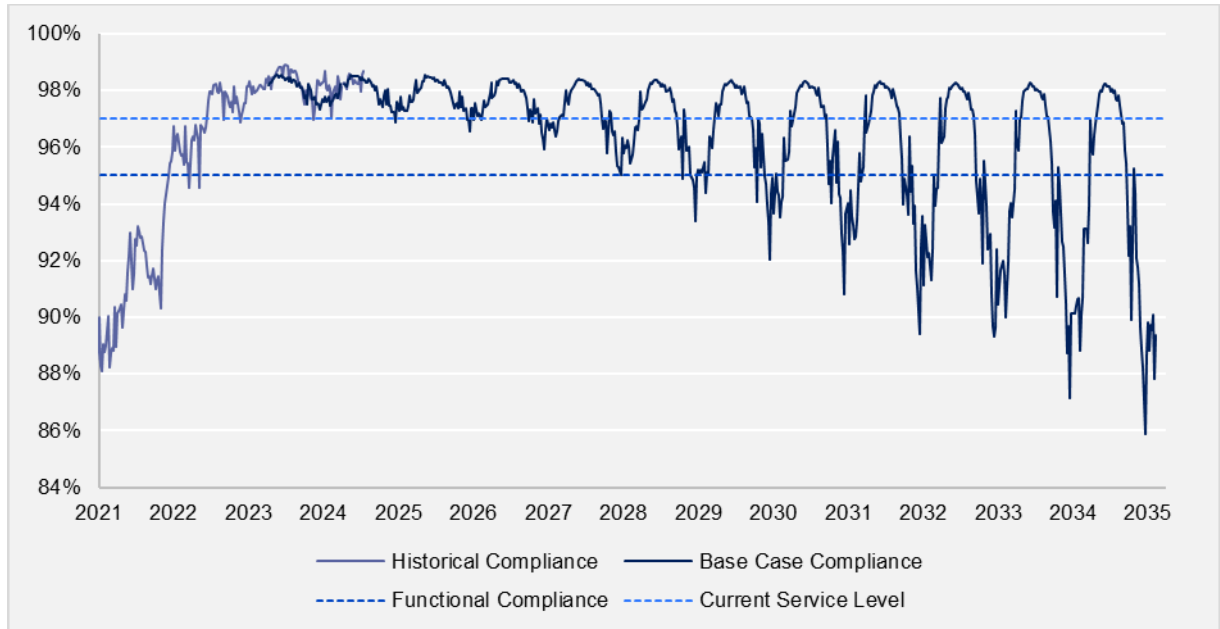

#### 10.3.1 Formulae

**EQUATION 19 V99 AVG VOLTAGE VALUE**

$$v99 \text{ avg value} = \frac{v99 \text{ avg} \times v \text{ base}}{\sqrt{3}}$$

**EQUATION 20 OVERVOLTAGE CUSTOMER COMPLIANCE**

$$V99 \text{ Compliance (\%)} = \frac{1}{1 + e^{-k(v99 \text{ avg value} - x_0)}}$$

*Overvoltage Compliant customers = V99 Compliance × 'Customer Count'*  
(rounded to nearest customer)

For each week, sum the total number of unconstrained customers and divide by total customers to obtain network compliance for a given week.

For reference, tags used in this section of the model are at table 18.

**TABLE 18      OVERVOLTAGE COMPLIANCE TAGS**

<b>TAG</b>	<b>UNIT</b>	<b>SOURCE TABLE</b>
conducting_equipment_mrid		Weekly Report
mz_type		Weekly Report
v_base	V	Weekly Report
v99_avg	p.u	Weekly Report
Timestamp	dd-mm-yyyy	Weekly Report



# 11. Modelling augmentations in weekly voltage compliance

In this section we combine the 'All Economic Augmentation' list of sites from section 10 with the same methodology weekly voltage compliance charts generated in section 11 to quantify the number of customers enabled per week for each augmentation.

## 11.1 Formulae

### EQUATION 21 DSS OFFLOAD VOLTAGE ALLEVIATION

$$\text{Voltage Spread Reduction} = \frac{(v99 \text{ avg value} - v1 \text{ avg value})}{2}$$

### EQUATION 22 RECONDUCTOR VOLTAGE ALLEVIATION

$$\text{Voltage Spread Reduction} = 9V \times 2 = 18V$$

### EQUATION 23 V1 AVG VALUE POST AUGMENTATION

$$v1 \text{ avg value post augmentation} = v1 \text{ avg value} + \frac{\text{Voltage Spread Reduction}}{2}$$

### EQUATION 24 V99 AVG VALUE POST AUGMENTATION

$$v99 \text{ avg value post augmentation} = v99 \text{ avg value} - \frac{\text{Voltage Spread Reduction}}{2}$$

## 11.2 Methodology

Join 'All Economic Alleviation' list from section 10 to the weekly compliance output from section 11. For each economic 'conducting\_equipment\_mrid', when timestamp > augmentation\_year then apply voltage alleviation from Equation 23 and Equation 24.

This generates the weekly output displayed in Figure 38

For each 'conducting\_equipment\_mrid', apply sigmoid function from Equation 18 and Equation 20 to the new 'v1\_avg\_value\_post\_augmentation' and 'v99\_avg\_value\_post\_augmentation' outputs. For each week, sum the total number of unconstrained customers and divide by total customers to obtain network compliance for a given week.

**FIGURE 37 ECONOMIC ALLEVIATION IN WEEKLY COMPLIANCE (V)**

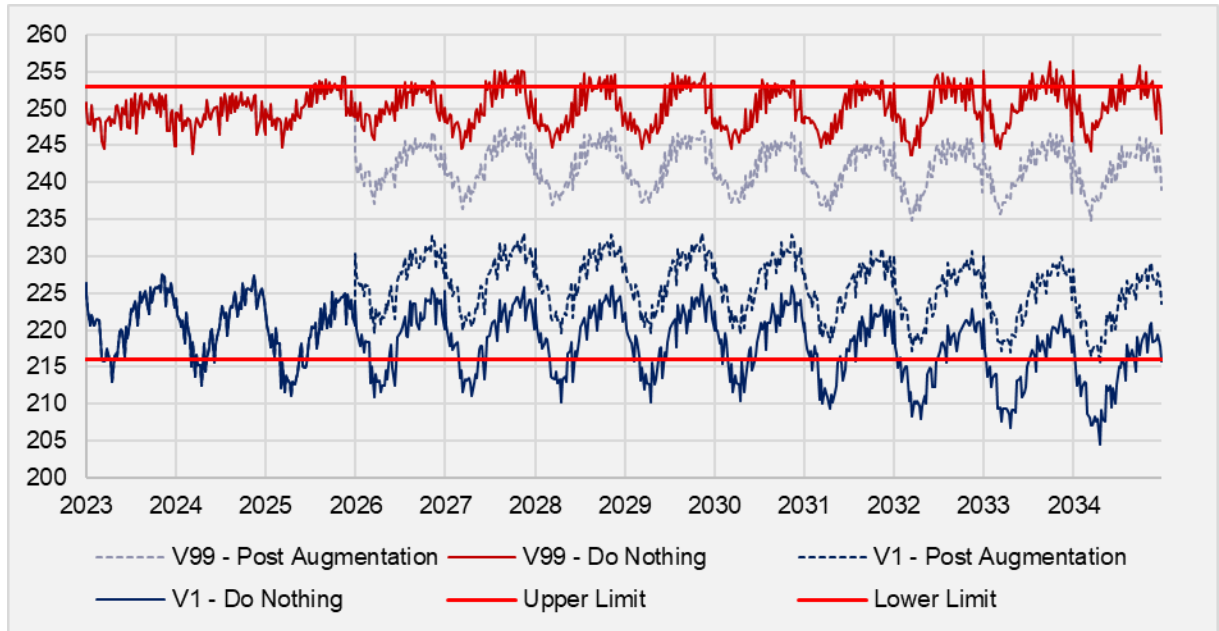
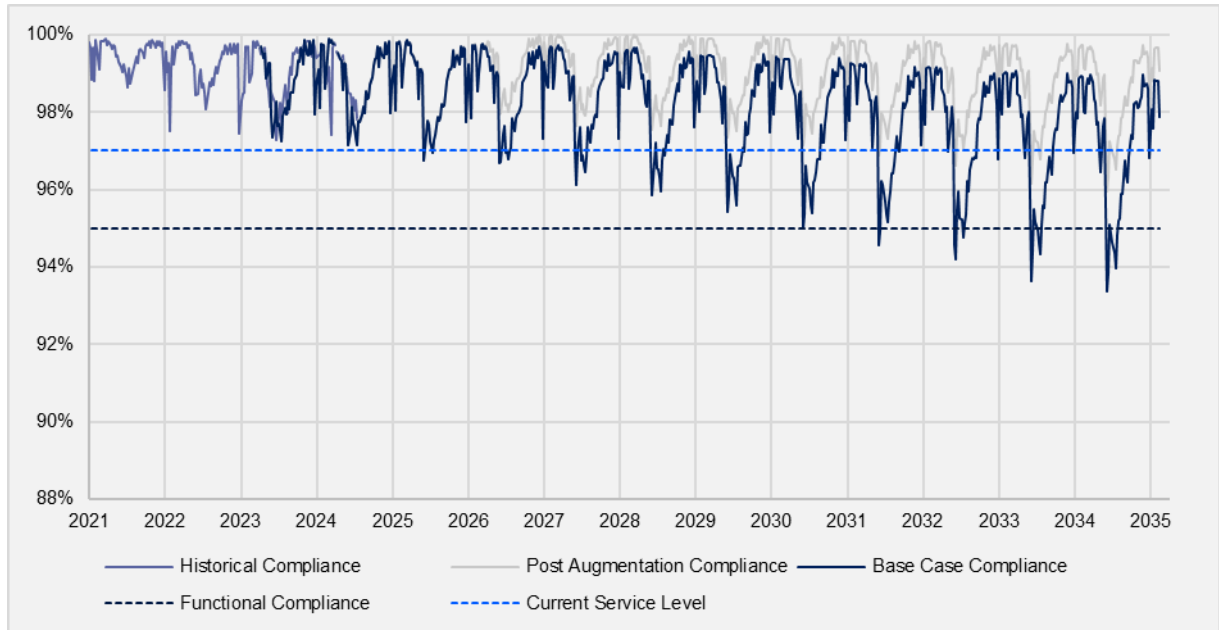

Figure 39 shows the aggregated output of economic alleviation.

**FIGURE 38 AGGREGATED OUPUT OF ECONOMIC ALLEVIATION (%)**



For reference, tags used in this section of the model are at table 19.

**TABLE 19 TAGS TO MODEL COMPLIANCE IN WEEKLY COMPLIANCE OUTPUTS**

<b>TAG</b>	<b>UNIT</b>	<b>SOURCE TABLE</b>
conducting_equipment_mrid		Section 11
V1_avg_value	V	Section 11
v99_avg_value	V	Section 11
Timestamp	dd-mm-yyyy	Section 11
augmentation_type		Section 10
augmentation_year	YYYY	Section 10

## 12. Generate service level results

The service level calculation aims to find the lowest cost possible to maintaining the target service level year on year. The base case voltage compliance forecast is modelled weekly for each lv circuit, and the lowest v1 compliance week is recorded for each distribution network. The number of alleviated customers from 'All Economic Augmentations' calculated in section 12 are used to feed into this approach.

**FIGURE 39 SERVICE LEVEL OUTPUT**

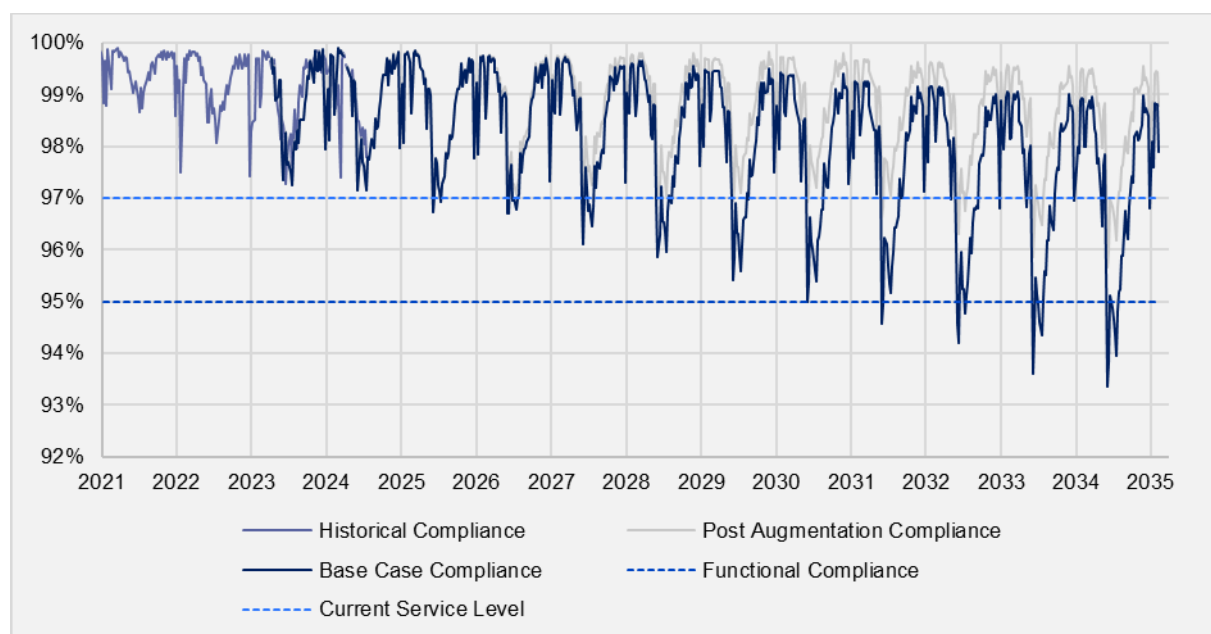

**EQUATION 25 CUSTOMER ENABLEMENT REQUIRED**

For each year:

$$\begin{aligned} \text{target non compliant customers} \\ &= (100\% - \text{service level target}) \times \text{customer count} + \text{customer offset} \end{aligned}$$

$$\text{customer enablement required} = \text{sum}(\text{non compliant customers}) - \text{target non compliant customers}$$

A customer offset is applied to the forecast v1 voltage compliance. The offset is needed to calibrate the model to be reflective of the actual observed compliance of the network.

The offset is determined for each network such that the minimum winter peak compliance aligns between actual and forecast compliance, for the time period of one year where both actual and forecast compliance data exists.

### 12.1 Methodology for site selection

For 2026:

1. Sort each 'conducting\_equipment\_mrid' ranking by highest customers enabled per dollar spent.
2. Cumulative sum of the total amount of customers enabled on a site by sites basis.
3. If customers enablement required  $\leq 0$  then no 'conducting\_equipment\_mrid' are selected for augmentation in that year.

4. If customers enablement required  $> 0$  then select all sites where the cumulative sum of enabled customers  $\leq$  customer enablement required, until customers enabled  $\geq$  customer enablement required.

For subsequent years:

1. Sort each 'conducting\_equipment\_mrid' ranking by sites already augmented, and then highest customers enabled per dollar spent.
2. Repeat process 2-4 from 2026 method until service level is met  
(note: sites already augmented contribute to the enabled customers but are not augmented again).

Figure 41 demonstrates a sample undervoltage compliance output.

**FIGURE 40 UNDERVOLTAGE COMPLIANCE SAMPLE OUTPUT**

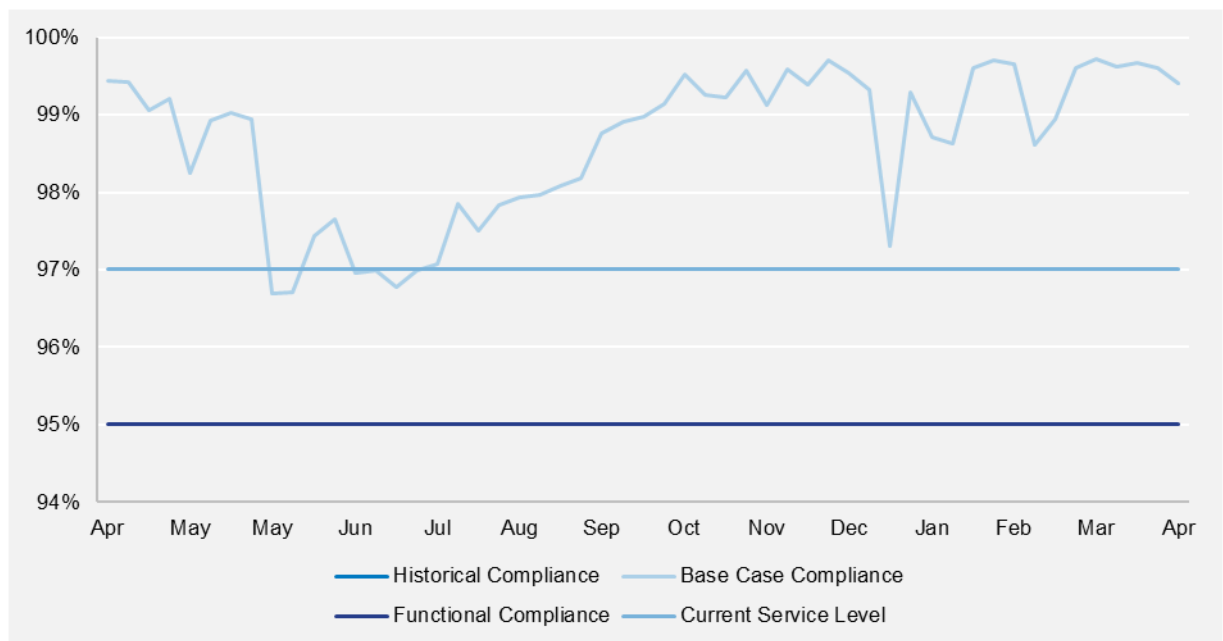
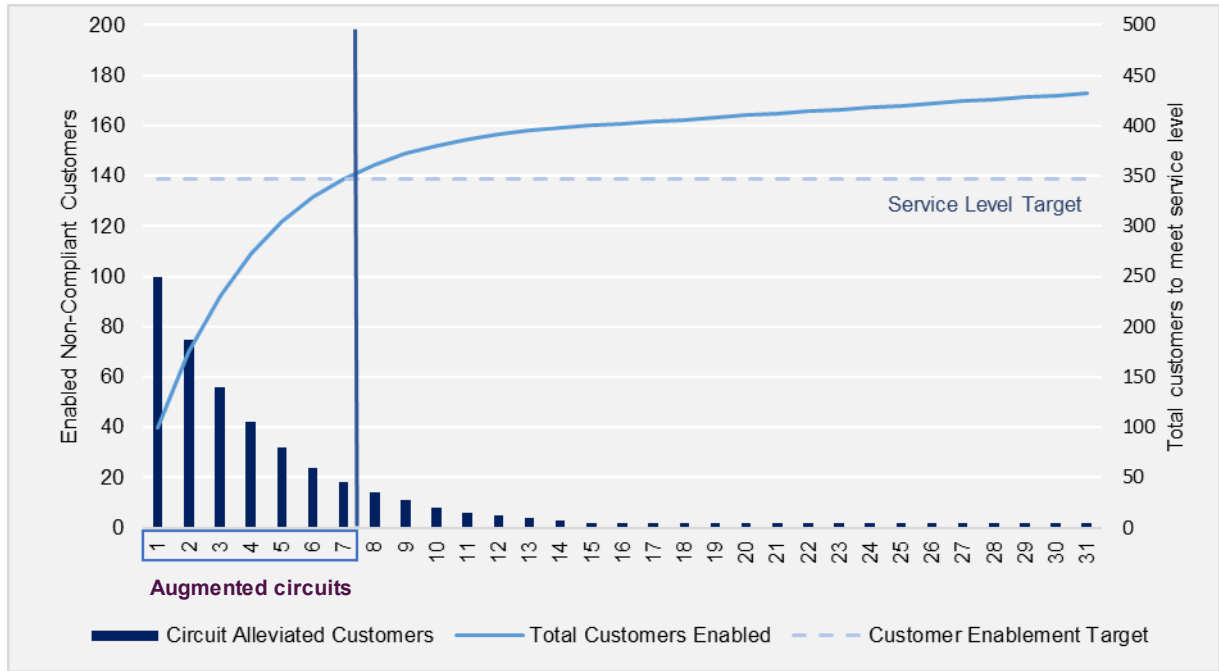

Figure 42 demonstrates how a site is selected to meet a service level target.

**FIGURE 41 SERVICE LEVEL SITE SELECTION METHODOLOGY<sup>2</sup>**



**12.1.2 Assumptions**

- The most efficient sites are selected for augmentation.
- Service levels are based on the lowest compliance week of the year.
- SWER sites upgraded to three phases as a part of the regional and rural program contribute to service level.

<sup>2</sup> The number of customers has been scaled down for illustration purposes

## 13. Predicting complaints from compliance

To predict the number of customer complaints, a study was done based on historical data that correlated the number of complaints against weekly voltage compliance. The data revealed a strong relationship with complaints increasing as voltage compliance decreased. To predict the likely number of complaints based on forecast voltage compliance, a mathematical model was developed. Using the exponential function, the model incorporates specific parameters for each network, to accurately estimate weekly customer complaints in relation to voltage compliance forecasts, shown at Figure 43.

**FIGURE 42 WEEKLY COMPLAINTS TREND (% OF COMPLAINTS / WEEKLY COMPLAINTS)**

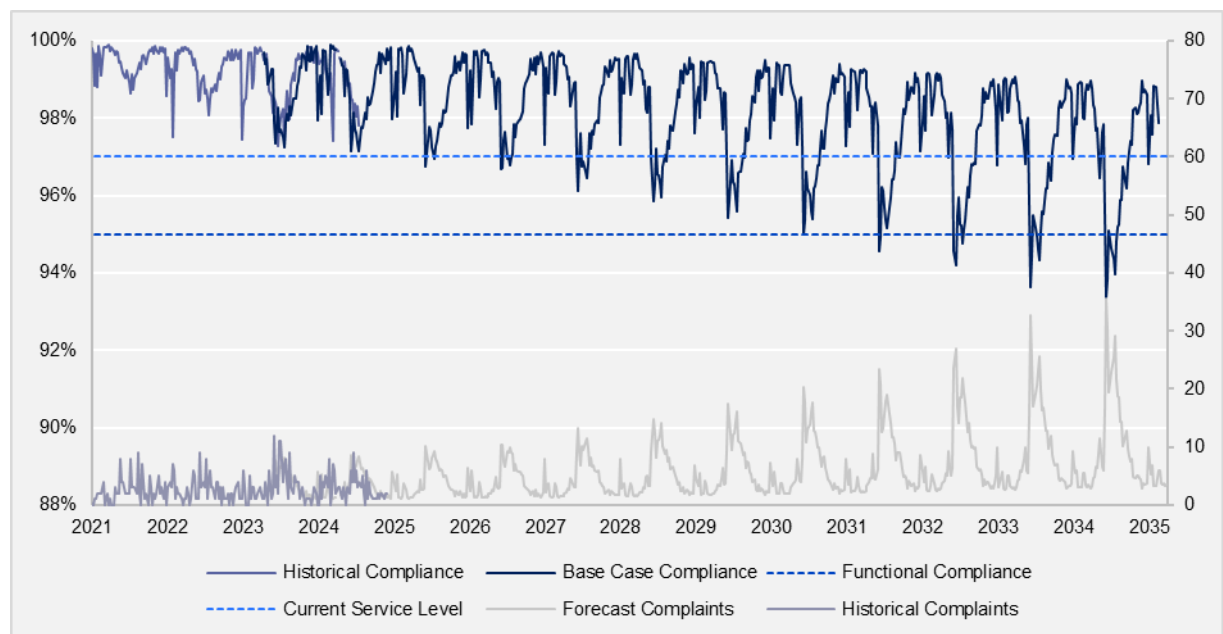

Equation 26 and Figure 44 explain the calculation the predict complaints.

### EQUATION 26 CUSTOMER COMPLAINT PREDICTION

$$\text{Customer complaints} = e^{-k(x-1)} + b$$

Where,

k is the decay constant that controls the rate of decay.

x is the weekly voltage compliance (independent variable for each network).

b is the vertical shift of the function, which adjusts the baseline of exponential decay.

**FIGURE 43 HISTORICAL WEEKLY COMPLAINTS VS COMPLIANCE**

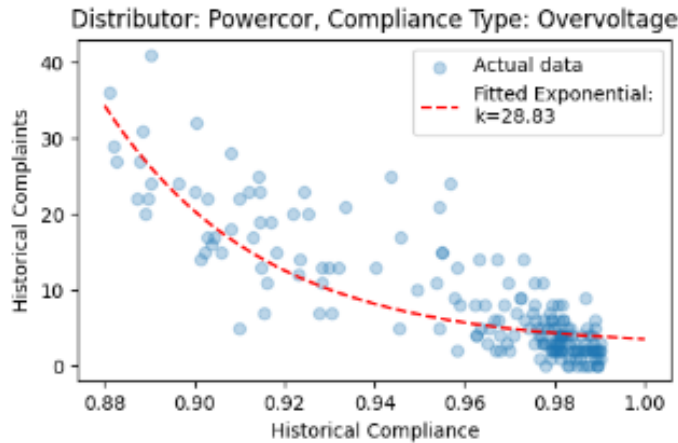

**TABLE 20 EXPONENTIAL FORMULA PARAMETERS PER NETWORK**

B	CITIPOWER	POWERCOR	UNITED ENERGY
overvoltage	-0.62	2.54	-0.19
undervoltage	-0.72	0.74	0.56

### 13.1 Estimating reactive projects from weekly complaints:

For each week, the number of projects eventuating from a customer complaint is estimated using the formula:

**EQUATION 27 COMPLAINT TO AUGMENTATION PROJECT CONVERSION**

$$\text{Number of Projects} = \text{Number of Complaints} \times \text{Reactive Conversion Factor}$$

Where:

'Number of Complaints' refers to the predicted complaints to occur for the forecast weekly voltage compliance.

'Reactive Conversion Factor' is a coefficient used to convert the number of complaints into estimated projects. Recognising that not all complaints result in a project, the conversion factor was calculated using an average of the number of complaints divide by the number of projects completed for the year.

**EQUATION 28 FORMULA FOR CONVERTING THE NUMBER OF COMPLAINTS INTO ESTIMATED PROJECTS.**

$$\text{Reactive Conversion Factor} = \frac{\text{Historical Yearly Number of Complaints}}{\text{Historical Yearly Number of Projects}}$$

**TABLE 21 REACTIVE PROJECT CONVERSION FACTOR**

	CITIPOWER	POWERCOR	UNITED ENERGY
Reactive Conversion Factor	56%	33%	30%



Historically, CitiPower network receives lower yearly volume of complaints than Powercor and United Energy due to it being a smallest of the three networks. However, of the customer complaints that are investigated a high percentage require a project to resolve the issue. Using a historical average conversion factor accounts for the years where the yearly compliance was relatively low and a high number of projects were completed.

Additional consideration is given regarding a marginal increase in the Reactive Conversion Factor for options in which voltage compliance declines. This increase accounts for the interdependency between declining undervoltage compliance (affecting customer satisfaction) with a respective rise in reactive projects. As forecast voltage compliance declines (refer to section 11.2), more customers are impacted by non-compliant voltage levels leading to more complaints and thus more reactive projects. Options that maintain or improve compliance maintains the current levels of conversion as compliance is maintained or improved.

**FIGURE 44 REACTIVE CONVERSION FACTORS FOR OPTIONS WITH DECLINING VOTLAGE COMPLIANCE**

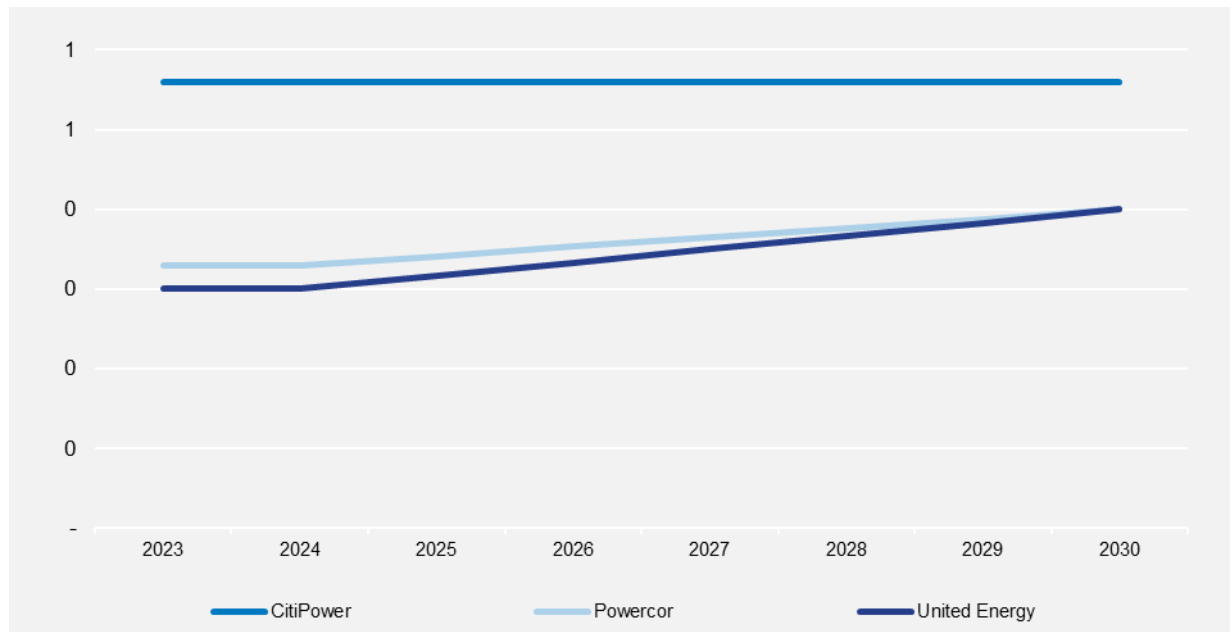

### 13.1.1 Forecasting costs to resolve a customer complaint

In the context of project cost management for reactively responding to a customer complaint, the approach can involve addressing varying level of issues. When investigating a customer enquiry, the nature of complaints can range from a single customer to broader systemic problems affecting multiple customers.

The distribution network characteristics (e.g., age, load distribution, geographic factors) will also influence the severity and complexity of these issues. For instance, an undervoltage complaint in an older part of the network may require a larger-scale upgrade to the infrastructure, whereas an overvoltage complaint might only need a simple adjustment to resolve.

#### Estimating major and minor project costs:

Solutions have been categorised into two project categories, minor and major. Minor projects are typically low-cost, localised solutions that fix the issue for an individual customer or a very small group of customers. Larger, more capital-intensive (major) projects are needed when multiple customers are impacted or when investigations reveal the non-compliance issue is widespread. These complex

projects can cost significantly higher due to the need for investment in upgrading the existing network, or redesign and new installations to evenly distribute the load.

Equation 29 demonstrates how we calculate major and minor project costs.

**EQUATION 29 MAJOR AND MINOR PROJECT COSTS**

$$Total\ Major\ Project\ Cost = Number\ of\ Projects \times Major\ Conversion\ Factor \times Major\ Project\ Cost$$

$$Total\ Minor\ Project\ Cost = Number\ of\ Projects \times Minor\ Conversion\ Factor \times Minor\ Project\ Cost$$

Major Conversion Factor and Minor Conversion Factor are coefficients that adjust the estimated number of projects for major or minor work. The coefficient is calculated by analysing historical project portfolio and using a defined project cost threshold to calculate a percentage split between a major and minor.

Major Projects: These are projects where the cost is greater than \$70,000.

Minor Projects: These are projects where the cost is greater than \$10,000 but less than \$70,000.

Major Project Cost and Minor Project Cost represent the respective costs per project type. This was calculated by separating historical yearly projects (from 2020 to 2025) into the project categories to calculate the average project category cost. On average the Major and Minor project costs for Citipower are higher due to complex solutions required to resolve customer complaints in comparison to Powercor and United Energy, shown in Table 22.

**TABLE 22 PROJECT CATEGORY COST AND CONVERSION FACTORS**

	<b>CITIPOWER</b>	<b>POWERCOR</b>	<b>UNITED ENERGY</b>
Major Conversion Factor	76%	34%	39%
Minor Conversion Factor	24%	66%	61%
Major Project Cost	\$150k	\$113k	\$129k
Minor Project Cost	\$41k	\$36k	\$27k

It is also noted that the Major Conversion Factor is expected to increase over time for options in which voltage compliance degrades. There will be a greater need for major projects to address compliance at lower compliance level therefore, an increase in this factor ensures that the cost estimates reflect the growing number of major projects over time.

**FIGURE 45 MAJOR PROJECT CONVERSION FACTORS FOR OPTIONS WITH DECLINING VOLTAGE COMPLIANCE**

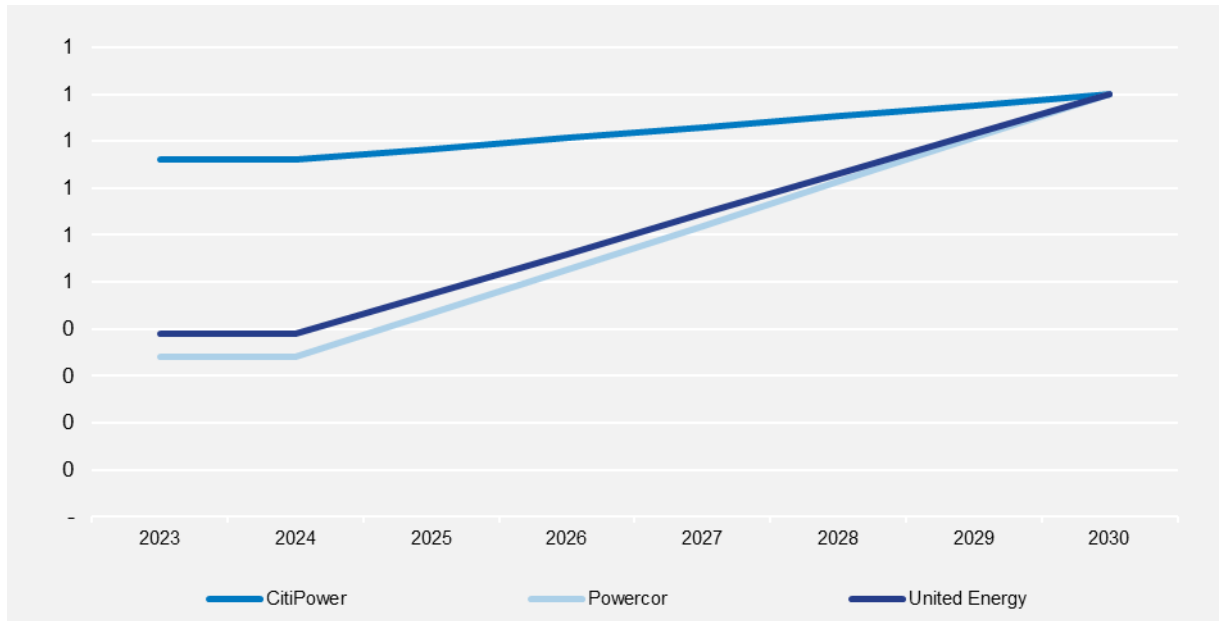

After calculating the individual costs for major and minor projects, the total weekly cost is calculated as:

**EQUATION 30 TOTAL WEEKLY COST**

$$Total\ Weekly\ Cost = Total\ Major\ Project\ Cost + Total\ Minor\ Project\ Cost$$

By using the Reactive Conversion Factor, Major and Minor Conversion Factor, along with the defined project costs for each category, we can accurately estimate the total project costs on a weekly basis. These estimations can be summed over the year for yearly cost projections.

## 14. HV cluster efficiency

A High Voltage (HV) cluster is a group of distribution substations (DSS) located in close proximity and connected to a common HV feeder or a spur of the feeder. Many HV feeders, installed decades ago, were built using conductors like SC/GZ 3/2.75 or Cu 7/.104. These conductors were sufficient for the lower loads at the time but have limited current-carrying capacity and higher impedance, making them inadequate to support the energy transition in rural areas and communities.

Upgrading the HV feeder by replacing undersized conductors with modern standards significantly improves voltage performance for the entire cluster. This approach is more efficient than upgrading individual DSS. LV constraints are assessed using the methodology for undervoltage as described in section 8.

Figure 47 visualises the impact of upgrading a HV feeder.

**FIGURE 46 IMPACT OF UPGRADING HV FEEDER**

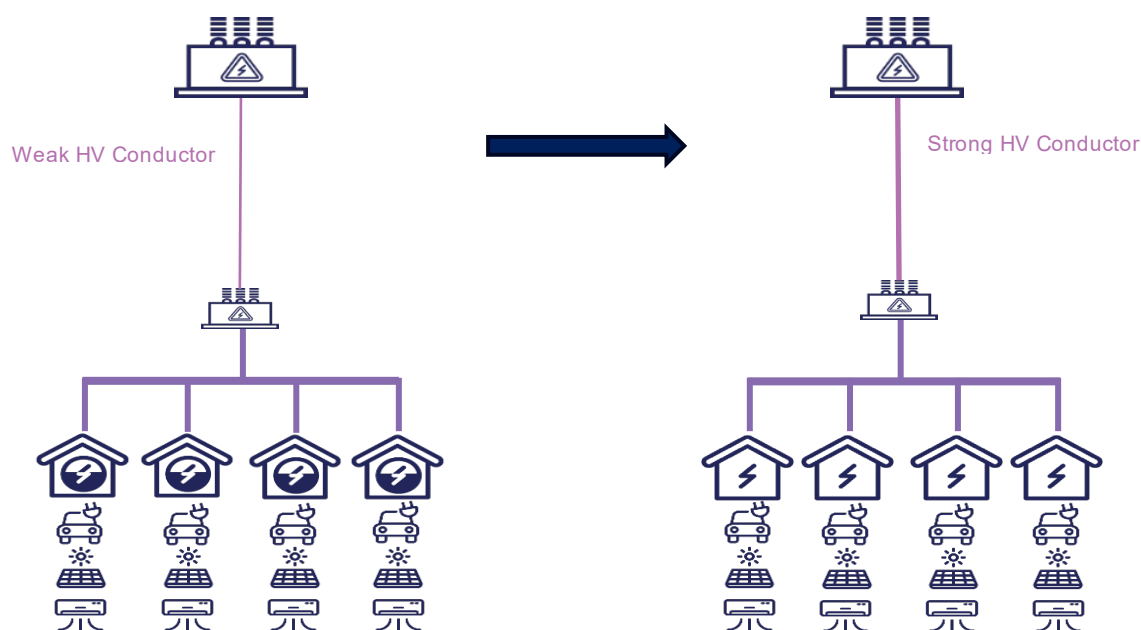

For reference, the tags used for this section of the model are at Table 23.

**TABLE 23 HV CLUSTER TAGS**

<b>TAG</b>	<b>UNIT</b>	<b>SOURCE TABLE</b>
mz_type		Network Performance Metrics
season		Network Performance Metrics
v_base	V	Network Performance Metrics
max_section_voltage	p.u	Network Performance Metrics
min_section_voltage	p.u	Network Performance Metrics
voltage_delta_max	p.u	Network Performance Metrics

**EQUATION 31 MAGNITUDE VOLTAGE SPREAD**

Filter on 'season' = "yearly"

$$\text{maxvoltage} = \frac{\text{maximum section voltage} \times v \text{ base}}{\sqrt{3}}$$

$$\text{minvoltage} = \frac{\text{minimum section voltage} \times v \text{ base}}{\sqrt{3}}$$

$$\text{magnitude voltage spread} = (\text{max\_voltage} - \text{min\_voltage})$$

**EQUATION 32 LV CIRCUIT SPREAD**

$$\text{lv circuit spread} = \frac{\text{voltage delta max} \times v \text{ base}}{\sqrt{3}}$$

Therefore, the HV contribution to the non-compliance is:

**EQUATION 33 HV CONTRIBUTION DEFINITION**

$$\text{HV Contribution} = \text{magnitude voltage Spread} - \text{lv circuit spread}$$

Figure 48 and the proceeding below exemplifies HV and LV cluster contributions.

**FIGURE 47 SCREEN TAKE FROM TABLEAU CLUSTER DASHBOARD**

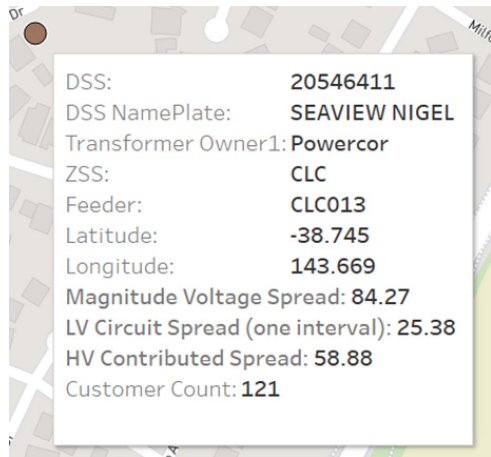

For this DSS with 121 customers, the HV Contributed spread of 58.88V is the majority of the Magnitude Voltage Spread of 84.27V. From this, it can be inferred that the voltage spread of the customers on this is largely due to HV.

One solution is to reconductor relevant sections of the HV feeder. Upgrading feeders with sparsely spaced DSS in long rural areas is an inefficient method for upgrading HV conductors. In contrast, areas with clustered, closely located DSS, such as townships with 500+ residents, would benefit more from HV reconductoring.

Figure 49 demonstrates this comparison.

**FIGURE 48 COMPARISON OF DSS SPACING**

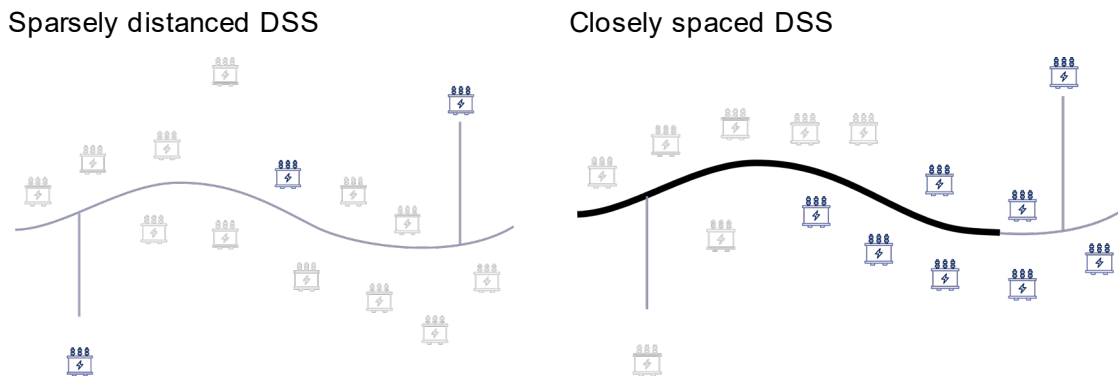

DSS that require augmentation are too few and too far apart for HV reconductor to be worthwhile.

There are many DSS that require augmentation, and they are all served off one feeder. Reconductoring the one HV feeder is a better outcome.

Figure 50 below shows HV feeders where upgrading the backbone conductor is more efficient than individual DSS augmentation.

**FIGURE 49 MAP OF HV CLUSTERS TAKEN FROM TABLEAU DASHBOARD**

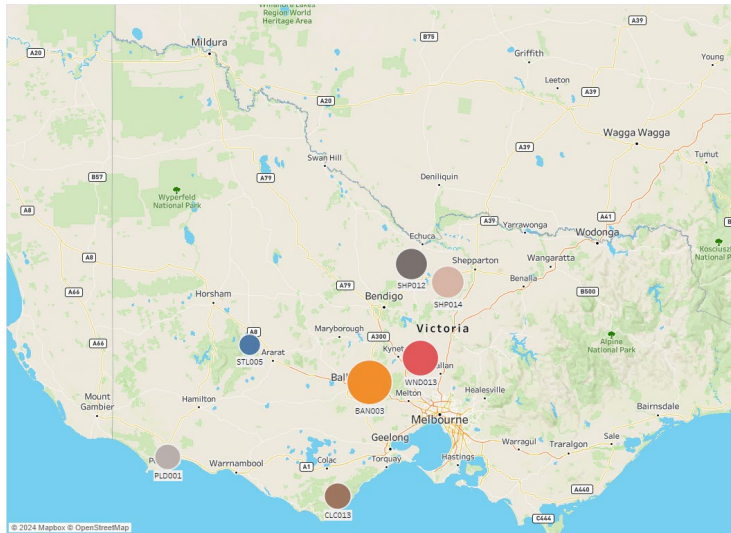

These sites have been included in the Powercor business case.

To determine the economic viability of upgrading the HV feeder, we apply this formula at .

**EQUATION 34 ECONOMIC VIABILITY OF UPGRADING HV**

If:

$$HV \text{ Feeder Upgrade Cost} < \sum \text{Individual DSS Augmentation Cost}$$

Then upgrading HV feeder is more efficient than upgrading individual DSS

## 15. Calculating flexible exports

We calculate the benefits of enabling export energy that would have been lost through static limits through flexible exports. Customers that are export limited based on constrained periods of the year, will be able to export during unconstrained periods where more network capacity is available.

Figure 51 demonstrates how this calculation is undertaken.

**FIGURE 50 FLEXIBLE EXPORTS CALCULATION**

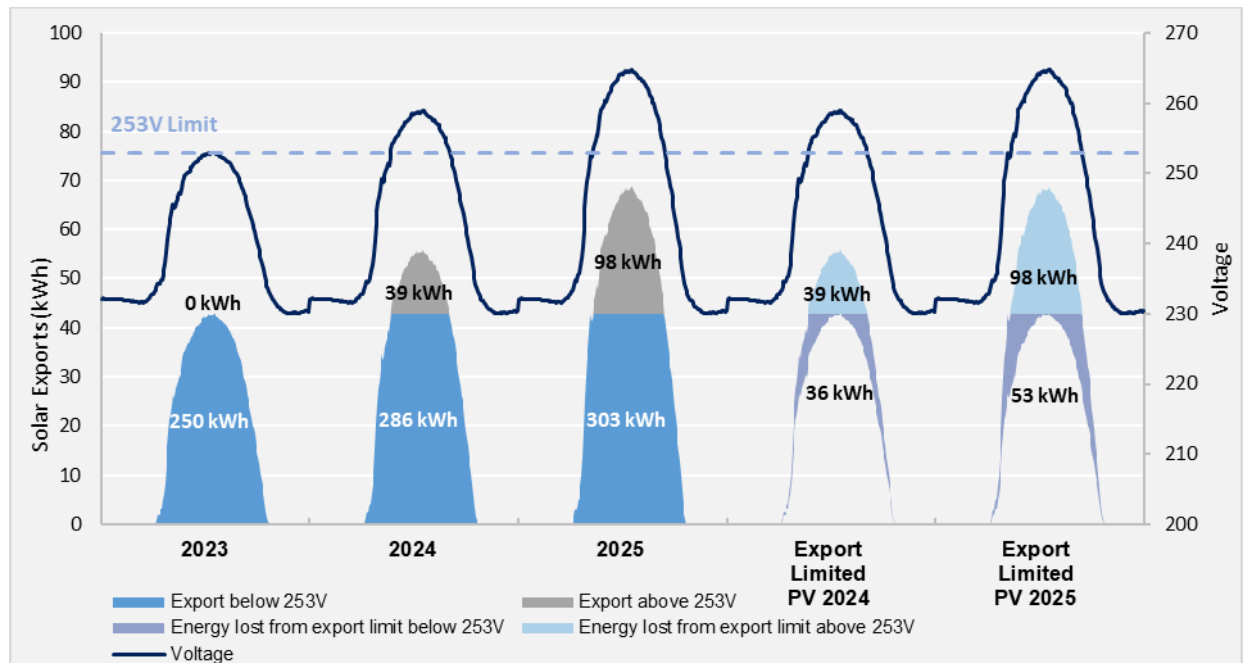

For reference, the tags used for this section of the model are at table 24.



**TABLE 24 FLEXIBLE EXPORT CALCULATION TAGS**

<b>TAG</b>	<b>UNIT</b>	<b>SOURCE TABLE</b>
v99 non-compliant customers	#	Section 11.3
Timestamp	dd-mm-yyyy	Section 11.3
generation_kwh	kWh	Section 11.3
gen_exceeding_normal_thermal_voltage_kwh	kWh	Section 11.3
generation_cecv	\$	Section 11.3
gen_exceeding_normal_thermal_voltage_cecv	\$	Section 11.3
generation_co2	\$	Section 11.3
gen_exceeding_normal_thermal_voltage_co2	\$	Section 11.3

**15.1.1 Formulae**

**EQUATION 35 CALCULATING INITIAL SOLAR CONSTRAINT WEEK**

*initial constraint week = min(timestamp) where 'v99 non compliant customers' > 0 & 'export energy at risk' > 0*

*Baseline Unconstrained year = date(initial constraint week – 1 year) → date(initial constraint week)*

**EQUATION 36 SETTING UP BASELINE UNCONSTRAINED WEEKLY EXPORTS**

Unconstrained baselines are calculated for each week in the baseline year as follows:

$$\text{Baseline Unconstrained Export kwh} = \text{generation\_kwh} - \text{gen\_exceeding\_normal\_thermal\_voltage\_kwh}$$

$$\text{Baseline Unconstrained Export cecv} = \text{generation\_cecv} - \text{gen\_exceeding\_normal\_thermal\_voltage\_cecv}$$

$$\text{Baseline Unconstrained Export co2} = \text{generation\_co2} - \text{gen\_exceeding\_normal\_thermal\_voltage\_co2}$$

**EQUATION 37 CALCULATING FLEXIBLE EXPORT BENEFITS**

For constrained sites when timestamp > End week of Baseline Period, Raw Flexible Export Values

$$\text{Flexible Enabled export enabled kwh} = \text{generation\_kwh} - \text{gen\_exceeding\_normal\_thermal\_voltage\_kwh} - \text{Baseline Unconstrained Export kwh}$$

*Flexible Enabled export enabled cecv = generation\_cecv –  
gen\_exceeding\_normal\_thermal\_voltage\_cecv – Baseline Unconstrained Export cecv*

*Flexible Enabled export enabled co2 = generation\_co2 –  
gen\_exceeding\_normal\_thermal\_voltage\_co2 – Baseline Unconstrained Export co2*

### **EQUATION 38          SCALING FLEXIBLE EXPORT BENEFITS**

Then Flexible exports are scaled:

$$Export\ Ratio = \frac{5565kwh}{6300kwh} = 88.3\%$$

*Flexible Enabled export values = Raw Flexible Export Values × Export Ratio*

#### **15.1.2 Assumptions**

- 5 KVA solar system exports 5,565 kwh (or 1,113kwh per kVA) a year, meaning 88.3% of generation is exported, reducing all flexible export energy metrics by 11.7%.
- Takes a conservative approach by assuming we export limit only due to voltage constraints and not thermal constraints.
- Reduces the thermal export outside of normal network limits (including conductors and service lines).

## 16. Voltage compliance POE 10 forecast

This analysis estimates the impact on voltage compliance metrics when switching the input of a complex model from POE50 (50th percentile maximum demand forecast) to POE10 (10th percentile maximum demand forecast), which represents higher peak loads. This script simplifies and approximates the compliance impact through several key transformations and analyses, shown at figure 52.

**FIGURE 51 P10 COMPLIANCE FORECAST (%)**

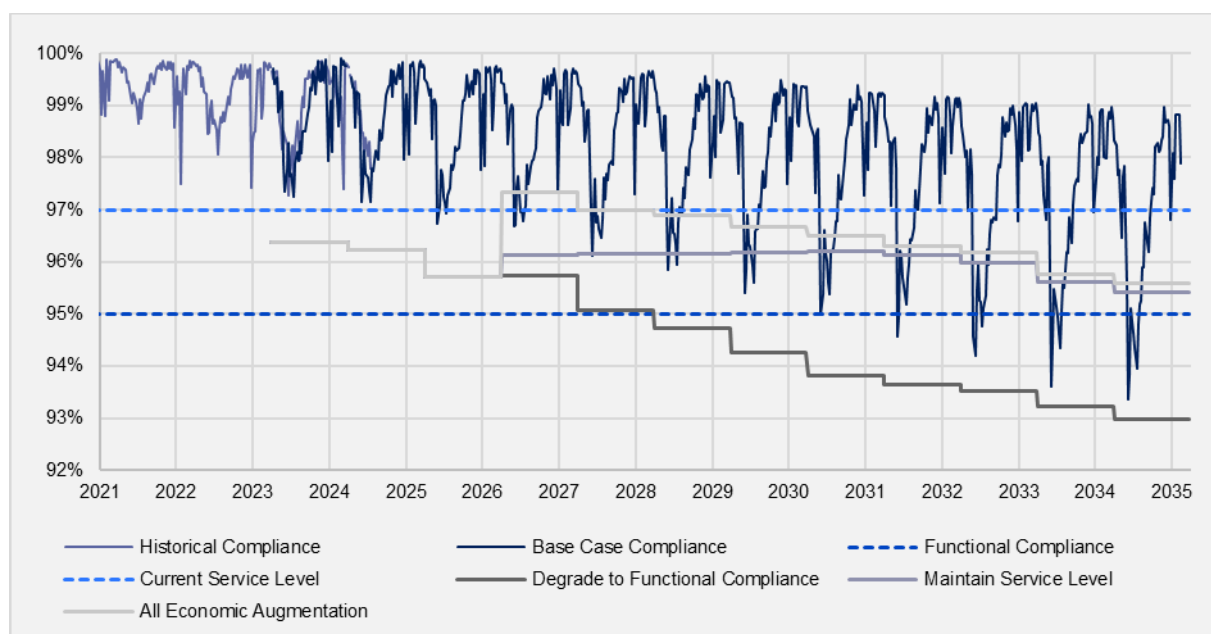

### 16.1 Logic for detecting compliance peaks by season

1. For each weekly timestamp create year, season, and month columns
2. Number each season in the time range chronologically
3. Detect the largest compliance peak for each numbered season

### 16.2 Logic for modelling the effect of POE10 versus POE50

1. Calculate percentage difference between POE10 and POE50 (typically 3%-5%)
2. Get 'v1\_avg' data from weekly voltage compliance charts. Assume that the percentage difference between POE10 and POE50 is related to the percentage difference of the v1\_avg distribution width.
3. Construct modelling features by:
  - Shifting 'v1\_avg' by percentages in the range 0%-6%.
  - Counting the number of rows with shifted v1\_avg < 216 V (i.e. under-voltage)
  - Normalise the counts by dividing by the first count value (i.e. from year 2023). This quantity, named 'normalised\_undervoltage\_factor', is  $\geq 1$  and is assumed proportional to the number of non-compliant customers. A normalised\_undervoltage\_factor > 1 therefore will bring down the POE10 adjusted compliance

4. Fit an exponential model to *normalised\_undervoltage\_factor* as a function of shift in percentage from 0%-6%
5. From the detected compliance peaks, predict *normalised\_undervoltage\_factor* from POE10 / POE50 using the fitted parameters
6. Calculate estimated compliance value POE10 from the predicted *normalised\_undervoltage\_factor*

**EQUATION 39                  EXPONENTIAL MODEL FUNCTION**

$$\textit{normalised_undervoltage_factor} = e^{k(x-x_0)} + b - 1$$

Where,

k is the exponential growth parameter

x is the shift in percentage

x0 is a fitted parameter that shifts the function horizontally

b is a fitted parameter that shifts the function vertically

## 17. Regional and rural equity – SWER upgrades

We supply electricity to over 540,000 regional and rural customers, including over 28,000 regional and rural customers are supplied by Single Wire Earth Return (SWER) line networks that we operate and maintain. The nature of the network that supports regional and customers typically has limited capacity and relatively low reliability, and power quality compared to urban networks. This network and corresponding customer experience is being challenged by the changing needs of regional and rural communities in a rapidly electrifying world. As a result, we are proposing to begin an economic program to upgrade targeted sections of our SWER network to three-phase. This would improve the ability of regional and rural customers to participate in the energy transition through an investment program that adds additional capacity for customers currently serviced by SWER networks

### 17.1 Risk calculation

Energy at Risk values for SWER sites are determined using the methodology outlined in section 8. In addition to Energy at Risk, bushfire risk is factored into the calculation of total risk, based on the Bushfire Category Areas (BCA). These values are then aggregated at the upstream SWER ISO transformer, as illustrated in Figure 53.

**FIGURE 52 AGGREGATION AT THE UPSTREAM SWER ISO TRANSFORMER**

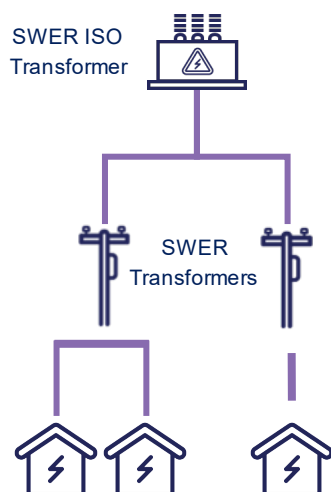

### 17.2 Cost of upgrades

For each SWER ISO site, the upgrade cost was calculated using the formula provided below.

**EQUATION 40 SWER ISO COST OF UPGRADE**

- $SWER\ ISO\ Upgrade\ Cost(\$) = BCA\ factor \times \sum(\text{construction cost} + \text{transformer upgrade cost} + \text{pole replacement cost} + \text{HV switch cost})$

The BCA Factor represents an additional cost applied to sites located in high bushfire risk areas, potentially increasing the project cost by up to 150%.

The upgrade cost was derived from similar historical projects and by conducting high-level scope designs on several case studies involving the SWER to three-phase networks upgrades. Table 25 below shows the unit cost used for each item.

**TABLE 25 SWER ISO UNIT COSTS**

<b>DESCRIPTION</b>	<b>UNIT COST</b>	<b>NOTES</b>
Construction Cost - Per Kilometre	\$63,441	Like for like replacement
Pole Replacement – Per Item	\$3,224	Same number of poles on same location
Transformer Upgrade – Per Item	\$7,402	Up to 100kVA
HV Switch – Per Item	\$11,668	1 x HV Switch per existing SWER ISO

### **17.3 All economic upgrades**

An economic assessment was conducted for each SWER ISO site, following a similar approach to the methodology outlined in section 10. After determining the NPV and economic timing for each SWER ISO upgrade, sites with upgrade timings falling within the regulatory period were selected and prioritised based on their number of connected customers. This approach enables targeting sites with higher customer numbers earlier, thereby improving reliability and compliance for a larger customer base.



For further information visit:

 [Unitedenergy.com.au](http://Unitedenergy.com.au)

 United Energy

 United Energy

 United Energy